

Adjustable thermostatic mixing valve for solar systems

252 series

**CALEFFI
SOLAR**



General

In solar systems, the temperature in the storage tank can vary considerably, depending on the solar radiation, and can reach very high temperatures over long periods. In summer, and if there is little water usage, the hot water at the storage tank outlet can actually reach temperatures around 200° F. At these temperatures, the hot water cannot be used directly because of the danger of scalding.

Function

The thermostatic mixing valve is used in systems for scald protection in the production of domestic hot water. It is designed to maintain the set temperature of the mixed water supplied to the user when there are variations in the temperature and pressure conditions of the incoming hot and cold water or in the water's flow rate. This particular series of mixing valves can function continuously at the high temperatures of the incoming hot water from the solar storage tank.



Product range

Code 2521 series Adjustable thermostatic mixing valve for solar systems _____ sizes 1/2", 3/4", 1" sweat
Code 2523 series Adjustable high flow thermostatic mixing valve for solar systems _____ sizes 3/4", 1" sweat

Technical specifications

Materials: - body: dezincification resistant alloy brass
- shutter: PSU
- springs: stainless steel
- seal components: EPDM

Setting range: 80—150°F (27—65°C)
Accuracy: ± 3°F (2°C)

Max. working pressure (static): 150 psi (10 bar)
Max. working pressure (dynamic): 75 psi (5 bar)
Min. working pressure (dynamic): 30 psi (2 bar)

Max. inlet pressures ratio (H/C or C/H): 2:1
Max. inlet temperature: 210°F (100°C)

Min. temperature difference between hot water at inlet and mixed water at outlet for optimum performance: 30°F (15°C)
Min. flow rate to ensure stable temperature:

- 2521 version: 1.3 gpm (5 lpm)
- 2523 version: 2.3 gpm (8.5 lpm)
Connections: - 2521 version: 1/2", 3/4", 1" with sweat union
- 2523 version: 3/4" and 1" with sweat union

Dimensions

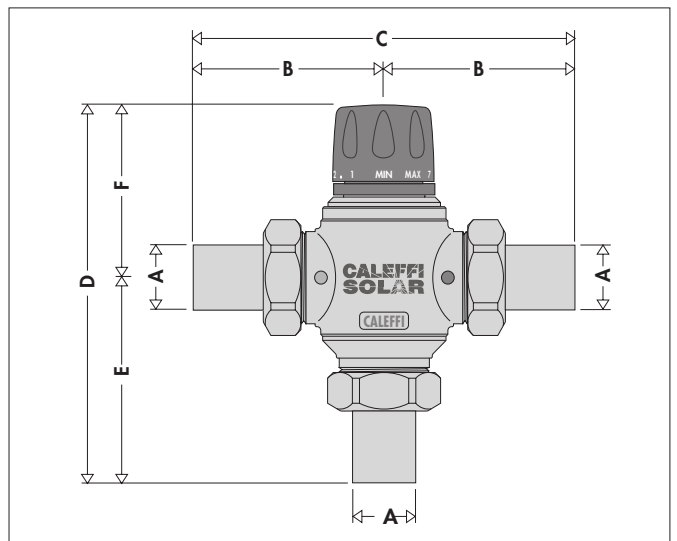
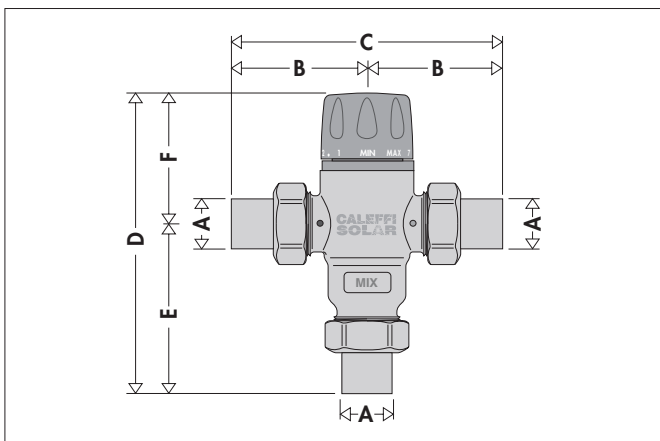

Code	A	B	C	D	E	F	Weight (lb)
2521 49A	1/2"	2 1/4"	4 1/2"	5 5/8"	3 1/8"	2 5/8"	2.2
2521 59A	3/4"	2 1/2"	5"	5 7/8"	3 1/4"	2 5/8"	2.4
2521 69A	1"	3 1/8"	6 1/4"	6 3/8"	3 7/8"	2 5/8"	2.6

Code	A	B	C	D	E	F	Weight (lb)
2523 59A	3/4"	3 1/8"	6 1/4"	6 3/4"	3 1/4"	3 1/2"	5.3
2523 69A	1"	3 5/8"	7 1/4"	7 1/4"	3 3/4"	3 1/2"	5.6

Operating principle

The controlling element of the solar thermostatic mixing valve is a temperature sensor that is fully immersed in the mixed water outlet passage. As it expands or contracts, the sensor continuously establishes the correct proportion of hot and cold water entering the valve. The flow is regulated by a piston sliding in a cylinder between the hot and cold water passages.

Even when there are pressure drops due to the drawing off of hot or cold water for other uses or variations in the incoming temperature, the mixer automatically regulates the water flow to obtain the required temperature.

Hydraulic characteristics

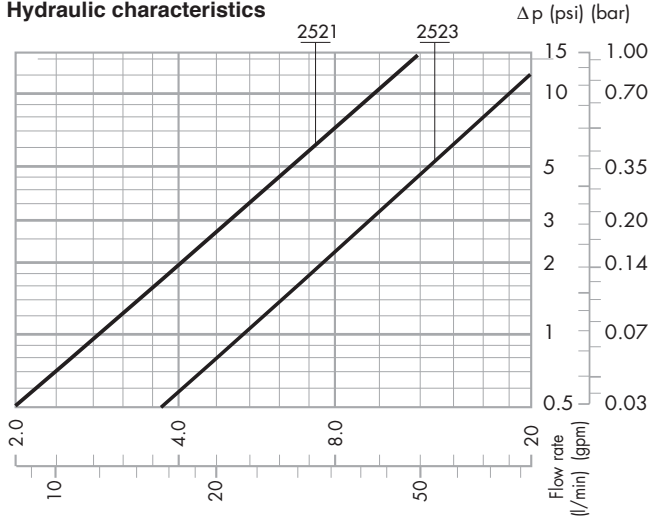

2521 series Cv 3.0 (gpm) (Kv 2.6 (l/min))
 2523 series Cv 5.5 (gpm) (Kv 4.6 (l/min))

Use

Thermostatic mixing valves are typically installed at the outlet of hot water storage tanks in solar systems to ensure constant temperature of the mixed water supplied to the end user. Because of their flow characteristics, the valves can be installed to control the temperature for both single point of use and for point of distribution. In order to guarantee the delivery of mixed water at the set temperature, the thermostatic mixing valves must have a minimum flow rate of:

2521 series min. flow of 1.3 gpm
 2523 series min. flow of 2.3 gpm

Application diagrams - System with thermal integration

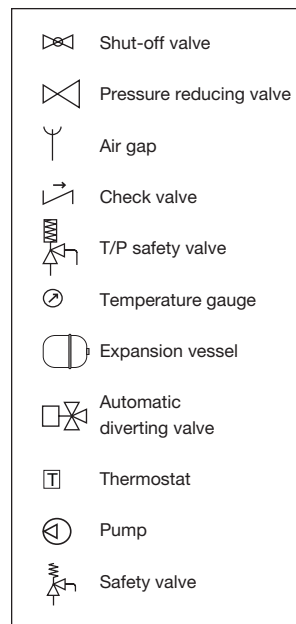
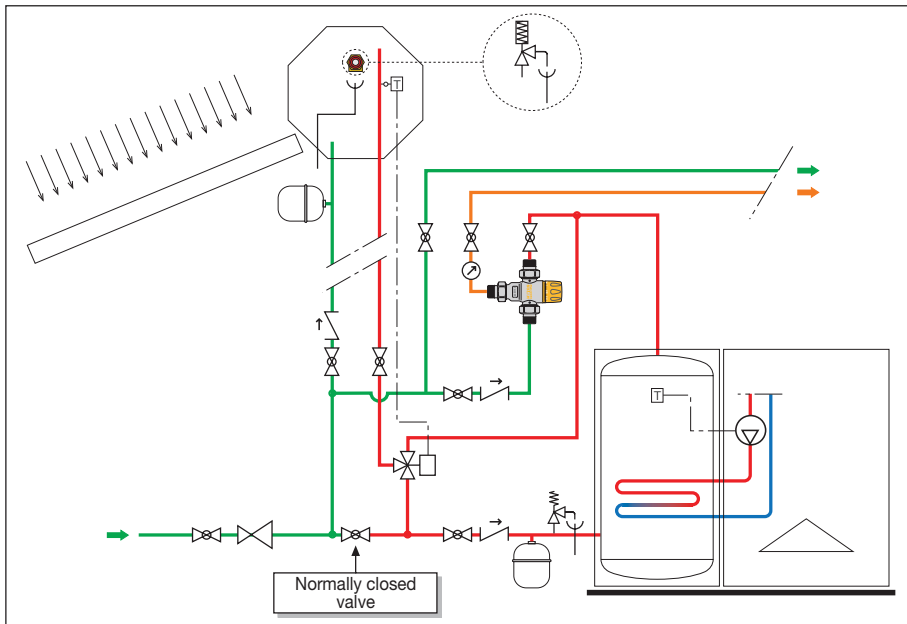

Installation

Before installing the mixing valve, the pipework must be flushed out to ensure that there are no circulating impurities to harm the system. We recommend always installing filters of sufficient capacity at the inlet of the water system.

Thermostatic mixing valves can be installed horizontally or vertically.

The following are indicated on the body of the mixing valve:

- hot water inlet, indicated with the color red and the word "HOT"
- cold water inlet, indicated with the color blue and the word "COLD"
- mixed water outlet with the word "MIX".

Temperature adjustment

The temperature is set at the desired value by the knob with the graduated scale, located on the top of the valve.

Temperature adjustment table

Position	Min.	1	2	3	4	5	6	7	Max.
T (°F)	80	90	100	110	120	130	135	145	150

Reference values: $T_{hot} = 155^{\circ}F$; $T_{cold} = 55^{\circ}F$; Hot and cold water inlet pressures = 45 psi

Locking the setting

After selecting the temperature, the setting can be locked at the desired value using the control knob.

To do this, unscrew the lock screw on the upper part of the control knob, remove the knob and put it back on so that the internal reference couples with the protrusion on the knob carrier ring nut.

