

# GAS FIRED WALL FURNACES MODELS 5001/8001 - 5002/8002 INSTALLATION INSTRUCTIONS AND OWNER'S MANUAL

**WARNING:** If the information in this manual is not followed exactly, a fire or explosion may result causing property damage, personal injury or loss of life.

- Do not store or use gasoline or other flammable vapors and liquid in the vicinity of this or any other appliance.
- **WHAT TO DO IF YOU SMELL GAS**
  - Open windows
  - Do not try to light any appliance
  - Do not touch any electrical switch; do not use any phone in your building.
  - Immediately call your gas supplier from a neighbor's phone. Follow the gas supplier's instructions.
  - If you cannot reach your gas supplier, call the fire department.
- Installation and service must be performed by a qualified installer, service agency or the gas supplier.

**WARNING:** If not installed, operated and maintained in accordance with the manufacturer's instructions, this product could expose you to substances in fuel or from fuel combustion which can cause death or serious illness and which are known to cause cancer, birth defects or other reproductive harm.

## DIRECT VENT WALL FURNACE MODELS 5001, 5002, 8001, 8002

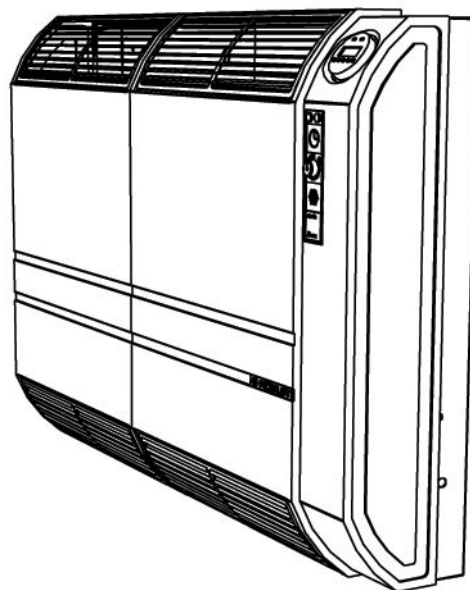

**EuroTherm Systems**

**ROBUR**  
caring for the environment

Edition: 06/2006

Codice: D-LBR420

This manual was written and printed by Robur S.p.A.; part or total reproduction of this manual is prohibited.

The original is filed in Robur S.p.A.

Any use of this manual other than personal consultation must be previously authorized by Robur S.p.A. All illustrations and specifications contained herein are based on the latest information available at the time of publication approval. Robur reserves the right to make changes at any time without notice, in materials, specifications, and models or to discontinue models.

---

## INDEX OF CONTENTS

<b>SECTION 1 GENERAL INFORMATION AND TECHNICAL DATA .....</b>	<b>3</b>
INSTRUCTIONS TO INSTALLER.....	3
GENERAL WARNINGS.....	4
TECHNICAL DATA.....	6
<b>SECTION 2 INSTALLATION .....</b>	<b>9</b>
WALL INSTALLATION .....	9
OUTSIDE LOCATION FOR VENT TERMINAL.....	11
GAS SUPPLY .....	16
ELECTRICAL WIRING DIAGRAMS.....	18
<b>SECTION 3 OPERATING INSTRUCTIONS .....</b>	<b>21</b>
OPERATING INSTRUCTIONS FOR MODELS 5001 and 8001 .....	21
OPERATING INSTRUCTIONS FOR MODELS 5002 and 8002 .....	22
<b>SECTION 4 SERVICING.....</b>	<b>25</b>
CHECKING AND ADJUSTING THE GAS MANIFOLD PRESSURE .....	25
CHECKING, REMOVING AND REASSEMBLING OF THE VENT – AIR INTAKE SYSTEM.....	25
LUBRICATION OF MOVING PARTS.....	26
FLAME VISUAL CHECK .....	26
<b>SECTION 5 PROGRAMMABLE TIMER.....</b>	<b>27</b>
OVERVIEW .....	27
SETTING AND ADJUSTMENT .....	28



## SECTION 1 GENERAL INFORMATION AND TECHNICAL DATA

This series is design certified to ANSI Z21.86-2004 / CSA 2.32-2004 Gas-Fired Gravity and Fan Type Direct Vent Wall Furnaces as a Fan Type Direct Vent Wall Furnace to be installed on an outside wall according to these instructions.

Any alteration of the original design, installed other than as shown in these instructions or used with a type of gas not shown on the rating plate **is the responsibility of the person and company making the change.**

### INSTRUCTIONS TO INSTALLER

Installation and repair should be done by a **QUALIFIED SERVICE PERSON.**

The installation must conform to local codes or in the absence of local codes, the installation must conform with the National Fuel Gas Code ANSI Z223.1/NFPA 54, Natural Gas and Propane Installation Code CSA B149.1.

Mobile (Manufactured) home installations must conform with the "Manufactured Home Construction and Safety Standard Title 24 CFR, Part 3280" or, when such a standard is not applicable, the Standard for Manufactured Home Installations, ANSI A 225.1 NFPA/501A, Mobile Home Standard, CAN/CSA Z240 MH Series, in Canada.

Installer must leave instruction manual with owner after installation. Installer must have owner fill out and mail warranty card supplied with furnace. Installer should show owner how to start and

operate furnace and thermostat. Installer should provide a 1/8 inch NPT plugged tapping for test gauge connection, immediately upstream of the gas supply connection of the appliance.

During initial firing of the furnace, residual manufacturing grease will bake out and smoke will occur which is not a health danger. To prevent nuisance and operation of fire alarms, ventilate the room for the first two hours of operation.

**WARNING: Any change to this furnace or its controls can be dangerous. This is a heating appliance and any panel, door or guard removed for servicing an appliance must be replaced prior to operating the appliance.**

### MODELS DESCRIPTION

The 5001, 8001, 5002, 8002 units are gas heaters, an independent heating product with an isolated combustion chamber and forced draught.

It can operate either with natural gas and liquid propane gas.

The combustion air intake and the exhaust of fumes are external to the system through two coaxial pipes and are drawn by the operation of an electric fan placed in the combustion circuit. The operation principle of the unit is based on a convective movement of the ambient air. The air going through the unit is drawn upwards and heated, then diffused in the ambient through the outlet grille. The natural movement of ambient air is aided by the presence of a fan placed in the lower section of the unit.

For correct operation of the unit, the grilles need to be free from clothes, newspapers or any other object that may obstruct the flow of air.

The operation of the unit is very simple and completely automatic thanks to the thermostatic regulation and the programmable timer (standard equipment on models 5002 and 8002, supplied as optional for 5001 and 8001). The end user only needs to start the unit and choose the desired temperature (to be selected on the thermostat); for models 5002 and 8002, also set the operation period of the unit on the programmable timer.

The isolated combustion chamber is a best safety feature as there is no risk of leakage of the combustion products.

A special flame detection device, that operates through a ionization flame sensor, immediately stops the gas supply in case the flame accidentally goes off.

Models 5002 and 8002 grant a higher comfort thanks to an air humidifier placed on the left hand side of the unit.

Additionally, models 5002 and 8002 can also operate in summer time (the fan can work while the burner is off). This allows a pleasant summer ventilation (movement of room air).

## GENERAL WARNINGS

**THIS IS A HEATING APPLIANCE: DO NOT OPERATE THIS APPLIANCE WITHOUT FRONT PANEL INSTALLED**

- **Due to high temperatures the appliance should be located out of traffic and away from furniture and draperies.**
- **Children and adults should be alerted to the hazards of high surface temperatures and should stay away to avoid burns or clothing ignition.**
- **Young children should be carefully supervised when they are in the same room as the appliance.**
- **Clothing or other flammable material should not be placed on or near the appliance.**
- **Any safety screen or guard removed for servicing an appliance must be replaced prior to operating the appliance.**
- **Keep burner and control compartment clean.**
- **The outside vent cap is hot while furnace is in operation.**
- **Installation and repair should be done by a QUALIFIED SERVICE PERSON. The appliance should be inspected before use and at least annually by a qualified service person.**
- **More frequent cleaning may be required due to excessive lint from carpeting, bedding materials, etc. It is imperative that control compartments, burners and circulating air passageways of the appliance be kept clean.**
- **DO NOT put anything around the furnace that will obstruct the flow of combustion and ventilation air.**
- **DO keep the appliance area clear and free from combustible materials, gasoline and other flammable vapors and liquids.**
- **DO examine venting system periodically and replace damaged parts.**
- **DO examine burner periodically. Clean and replace damaged parts.**
- **DO NOT use this heater if any part has been under water. Immediately call a qualified service technician to inspect the heater and to replace any part of the control system and any gas control which has been under water.**

## SAFETY INFORMATION FOR USERS OF LP-GAS

**Propane (LP-Gas) is a flammable gas which can cause fires and explosions. In its natural state, propane is odorless and colorless. You may not know all the following safety precautions which can protect both you and your family from an accident. Read them carefully now, then review them point by point with the members of your household. Someday when there may not be a minute to lose, everyone's safety will depend on knowing exactly what to do. If, after reading the following information, you feel you still need more information, please contact your gas supplier.**

### LP-GAS WARNING ODOR

**If a gas leak happens, you should be able to smell the gas because of the odorant put in the LP-Gas. That's your signal to go into immediate action!**

- Do not operate electric switches, light matches, use your phone. Do not do anything that could ignite the gas.
- Get everyone out of the building, vehicle, trailer, or area. Do that IMMEDIATELY.
- Close all gas tank or cylinder supply valves.
- LP-Gas is heavier than air and may settle in low areas such as basements. When you have reason to suspect a gas leak, keep out of basements and other low areas. Stay out until firefighters declare them to be safe.
- Use your neighbor's phone and call a trained LP-Gas service person and the fire department. Even though you may not continue to smell gas, do not turn on the gas again. do not re-enter the building, vehicle, trailer, or area.
- **Finally**, let the service man and firefighters check for escaped gas. Have them air out the area before you return. Properly trained LP-Gas service people should repair the leak, then check and relight the gas appliance for you.

### NO ODOR DETECTED – ODOR FADE

**Some people cannot smell well. Some people cannot smell the odor of the chemical stench put into the gas. You must find out if you can smell the odorant in propane.** Smoking can decrease your ability to smell. Being around an odor for a time can affect your sensitivity or ability to detect that odor. Sometimes other odors in the area mask the gas odor. People may not smell the gas odor or their minds are on something else. Thinking about smelling a gas odor can make it easier to smell.

**The odorant in LP-Gas is colorless, and it can fade under some circumstances.** For example, if there is an underground leak, the movement of the gas through soil can filter the odorant. Odorants in LP-Gas also are subject to oxidation. This fading can occur if there is rust inside the storage tank or in iron gas pipes.

The odorant in escaped gas can adsorb or absorb onto or into walls, masonry and other materials and fabrics in a room. That will take some of the odorant out of the gas, reducing its odor intensity.

LP-Gas may stratify in a closed area, and the odor intensity could vary at different levels. Since it is heavier than air, there may be more odor at lower levels. Always be sensitive to the slightest gas odor. If you detect any odor, treat it as a serious leak. Immediately go into action as instructed earlier.

### SOME POINTS TO REMEMBER

- **Learn to recognize the odor of LP-gas.** Your local LP-Gas Dealer can give you a "Scratch and Sniff" pamphlet. Use it to find out what the propane odor smells like. If you suspect that your LP-Gas has a weak or abnormal odor, call your LP-Gas Dealer.
- If you are not qualified, do not light pilot lights, perform service, or make adjustments to appliances on the LP-Gas system. If you are qualified, consciously think about the odor of LP-Gas prior to and while lighting pilot lights or performing service or making adjustments.
- Sometimes a basement or a closed-up house has a musty smell that can cover up the LP-Gas odor. Do not try to light pilot lights, perform service, or make adjustments in an area where the conditions are such that you may not detect the odor if there has been a leak of LP-Gas.
- Odor fade, due to oxidation by rust or adsorption on walls of new cylinders and tanks, is possible. Therefore, people should be particularly alert and careful when new tanks or cylinders are placed in service. Odor fade can occur in new tanks or reinstalled old tanks if they are filled and allowed to set too long before refilling.
- Cylinders and tanks which have been out of service for a time may develop internal rust which will cause odor fade. If such conditions are suspected to exist, a periodic sniff test of the gas is advisable. **If you have any question about the gas odor, call your LP-Gas dealer. A periodic sniff test of the LP-gas is a good safety measure under any condition.**
- If, at any time, you do not smell the LP-Gas odorant and you should, assume you have a leak. Then take the same immediate action recommended above for the occasion when you do detect the odorized LP-Gas.
- If you experience a complete "gas out" (the container is under no vapor pressure), turn the tank valve off immediately. If the container valve is left on, the container may draw in some air through openings such as pilot light orifices. If this occurs, some new internal rusting could occur. If the valve is left open, then treat the container as a new tank. Always be sure your container is under vapor pressure by turning it off at the container before it goes completely empty or having it refilled before it is completely empty.

**TECHNICAL DATA**

		5001	5002	8001	8002
OUTPUT HEATING CAPACITY	kW	4.25		6.98	
	kBTU/hr	14.514		23.817	
INPUT RATING (HI input)	kW	5.19		8.50	
	kBTU/hr	17.700		29.000	
MINIMUM INPUT RATING (LO input)	kW	—	3.84	—	5.89
	kBTU/hr	—	13.100	—	20.100
THERMAL EFFICIENCY (ON INPUT RATING)	%	82.00		82.13	

AIR FLOW	m <sup>3</sup> /h	220		450	
	cfm	129		265	
MINIMUM AIR FLOW	m <sup>3</sup> /h	—	160	—	330
	cfm	—	94	—	194
TOTAL ELECTRICAL LOAD	W	86		140	
LENGHT	mm	553		1006	
	in	21 6/8		39 5/8	
HEIGHT	mm	715		715	
	in	28 1/8		28 1/8	
DEPHT	mm	208		208	
	in	8 2/8		8 2/8	
WEIGHT	kg	26		42	
	lbs.	57		93	
GAS CONNECTION	“NPT	1/2 female		1/2 female	

WALL HOLE DIAMETER	mm	50		50	
	in	2		2	
AIR INLET DIAMETER	mm	49		49	
	in	1 7/8		1 7/8	
EXHAUST PIPE DIAMETER	mm	35		35	
	in	1 3/8		1 3/8	
MAX WALL THICKNESS	mm	500		500	
	in	19 5/8		19 5/8	
MIN WALL THICKNESS	mm	150		150	
	in	5 7/8		5 7/8	

Table 1 - Technical data 1/2

			5001	5002	8001	8002	
MANIFOLD PRESSURE	MAX	NATURAL GAS	mbar	7.7		8.0	
			in <sub>w.c.</sub>	3.1		3.2	
		LP	mbar	26.4		26.5	
			in <sub>w.c.</sub>	10.6		10.6	
	MIN	NATURAL GAS	mbar	—	4.6	—	4.6
			in <sub>w.c.</sub>	—	1.8	—	1.8
		LP	mbar	—	16.3	—	16.2
			in <sub>w.c.</sub>	—	6.6	—	6.5
GAS RATE	MAX	NATURAL GAS	m <sup>3</sup> /h	0.5		0.9	
			ft <sup>3</sup> /h	17.8		30.1	
		LP	m <sup>3</sup> /h	0.2		0.3	
			ft <sup>3</sup> /h	6.9		11.6	
	MIN	NATURAL GAS	m <sup>3</sup> /h	—	0.4	—	0.6
			ft <sup>3</sup> /h	—	13.3	—	21.3
		LP	m <sup>3</sup> /h	—	0.1	—	0.2
			ft <sup>3</sup> /h	—	5.3	—	8.7
MINIMUM INLET PRESSURE	NATURAL GAS	mbar	17.4		17.4		
		in <sub>w.c.</sub>	7.0		7.0		
	LP	mbar	27.4		27.4		
		in <sub>w.c.</sub>	11.0		11.0		

Table 2 - Technical data 2/2



## SECTION 2 INSTALLATION

Installation should be done by a QUALIFIED SERVICE PERSON.  
The furnace is to be located on an outside wall.

### WALL INSTALLATION

Minimum clearances from combustible construction:

- Unit to the top surface of carpeting, tile: 2 in. (50 mm).
- Unit to back wall (0" to spacers): 0 in. (mm).
- Vent to wall enclosure: 0 in. (mm).
- Unit to sidewalls: 3.15 in. (80 mm).
- Unit to ceiling: 10 in. (254 mm).

See Figure 1 on page 10 showing clearance for installation of vent cap.

Leave at least three feet in front of the wall furnace for servicing and proper operation. The wall furnace must be installed in such a way that the external casing can be completely removed for servicing.

If there is a shelf above the furnace, it shall be non combustible. For best performance, a minimum clearance of 4 in. (100 mm) is recommended between the furnace and the non-combustible shelf above it.

Gas utilization equipment in residential garages shall be installed so that all burners and burner ignition devices are located not less than 18 in. (460 mm) above the floor. Such equipment shall be located, or protected, so it is not subject to physical damage by a moving vehicle.

The vent terminal of a direct vent appliance, with an input of 50,000 BTU per hour (14.6 kW) or less shall be located at least 9" (230 mm) from any opening through which flue gases could enter a building. The bottom of the vent terminal

and the air intake shall be located at least 12 in. (300 mm) above grade.

**WARNING: The nearest point of the vent cap should be a minimum horizontal distant of six (6) feet (1,830 mm) from any pressure regulator. In case of regulation malfunction, the six (6) feet (1,830 mm) distance will reduce the chance of gas entering the vent cap.**

DO NOT cover the furnace.

Make sure that the correct gas supply is available.

The furnace requires a 120 V 60 Hz electrical supply.

The appliance, when installed, must be electrically grounded in accordance with local codes, or in the absence of local codes with the National Electrical Code ANSI/NFPA 70 (latest edition) or in Canada with CAN/CSA-C22.2 No. 3.

**WARNING: For the installation of this appliance the following items must be used as a vent-air intake system:**

- external vent cap part n. R-TRM003
- flanged air inlet tube part n. R-TBO002
- flue outlet tube part n. R-TBO075
- O-ring part n. N-GRG005

**(all these items are supplied with the appliance).**

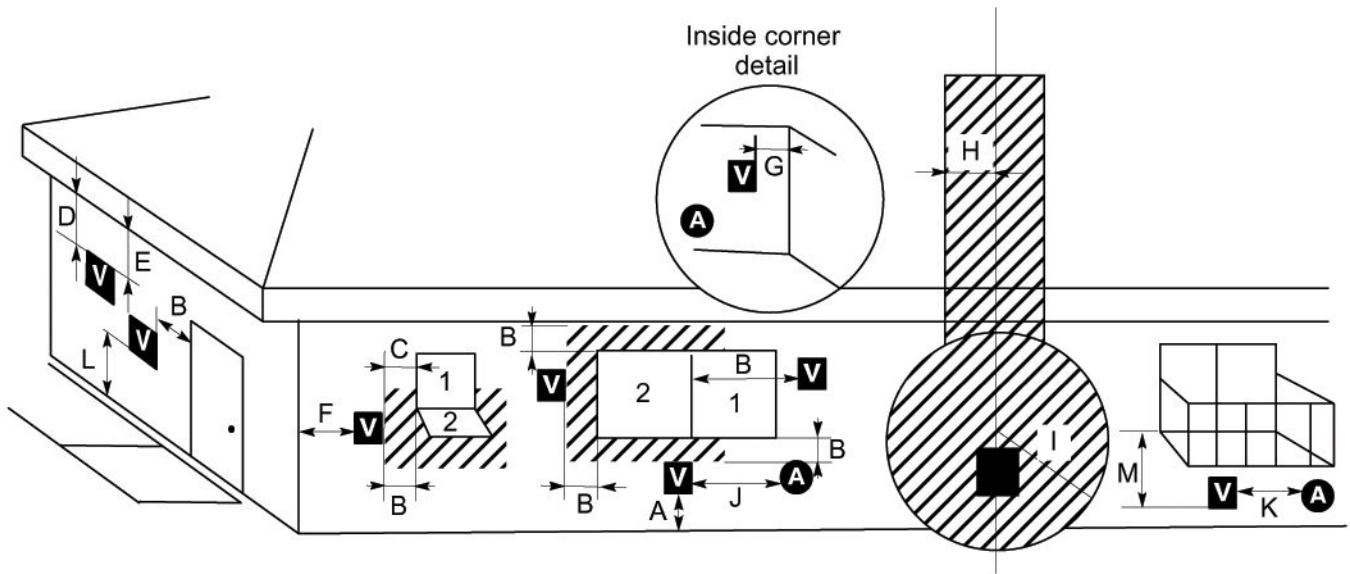

1 = fixed closed

2 = openable

V = vent terminal

A = air supply

- A. clearance above grade, veranda, porch, deck, or balcony (12 inches (30 cm) minimum) <sup>(3)</sup>
  - B. clearance to window or door that may be opened (12 inches (30 cm) minimum) <sup>(3)</sup>
  - C. clearance to permanently closed window (minimum 12 inches (30 cm) recommended to prevent condensation on window)
  - D. vertical clearance to ventilated soffit located above the terminal within a horizontal distance of 2 feet (60 cm) from the center-line of the terminal (18 inches (46 cm) minimum)
  - E. clearance to unventilated soffit (12 inches (30 cm) minimum clearance to vinyl soffit (36 inches (90 cm) minimum)
  - F. clearance to outside corner (12 inches (30 cm) minimum)
  - G. clearance to inside corner (18 inches (46 cm) minimum)
  - H. not to be installed above a meter/regulator assembly within 3 feet (90 cm) horizontally from the center-line of the regulator <sup>(3)</sup>
  - I. clearance to service regulator vent outlet (6 feet (1.8 m) minimum) <sup>(3)</sup>
  - J. clearance to non-mechanical air supply inlet to building or the combustion air inlet to any other appliance (12 inches (30 cm) minimum) <sup>(3)</sup>
  - K. clearance to a mechanical air supply inlet (6 feet (1.8 m) minimum) <sup>(3)</sup>
  - L. clearance <sup>(1)</sup> above paved side-walk or a paved driveway located on public property (7 feet (2.1 m) minimum) <sup>(3)</sup>
  - M. clearance under veranda, porch, deck or balcony (12 inches (30 cm) minimum) <sup>(2)</sup> <sup>(3)</sup>
- Notes:
- (1) a vent shall not terminate directly above a side-walk or paved driveway which is located between two single family dwellings and serves both dwellings <sup>(3)</sup>.
  - (2) only permitted if veranda, porch, deck or balcony is full open on a minimum of 2 sides beneath the floor
  - (3) as specified in CGA B149 installation codes (1991). Note: local codes or regulations may require different clearances.

Figure 1 - Installation clearances for safety, maintenance, correct operations

## OUTSIDE LOCATION FOR VENT TERMINAL

Upon delivery check to make sure the packaging has not been damaged. If this arises contact the shipping agent immediately.

1. Remove the furnace from box/packaging taking care not to damage the paper template. This is to be used to mark the holes for mounting the heater.
2. After marking where the appropriate holes will be by using the template mentioned above, make a 2 in. diameter hole. If a hole is already present from a previous heater, use the Retrofit/Vinyl Adapter Kit to compensate for the size difference. This kit can also be used to extend the placement of the vent on houses with vinyl siding. If you are using the Retrofit/Vinyl Adapter Kit, install the plate using the instructions included with the kit before proceeding.
3. Cut the combustion exhaust and fresh air inlet tubes according to the wall thickness (see Figure 2 below). Air inlet tube length = wall thickness + 3/32 in. Flue outlet tube length = wall thickness + 1-5/16 in. If you are using the Retrofit/Vinyl Adapter Kit, you will need to include the distance the plate extends from the wall in your measurement of the wall thickness.
4. Drill the fixing holes A (5 holes for 5001/5002, 8 holes for 8001/8002) in the wall. If the wall can receive self-tapping screws, drill 1/8 in. diameter. If not, drill 1/4 in. diameter and use the plastic anchors provided.
5. Install the supporting bracket to the wall; insert the air pipe in the wall through the hole provided in the support bracket. Place the round adhesive gasket around the hole, so that the air pipe remains on its positions (see Figure 3 and Figure 4 on page 12).
6. Fix the supporting bracket with the screws. Use self-tapping screws if the wall can receive them. If not, use the plastic anchors provided.
7. Remove the casing loosening the fixing screws (see Figure 5 on page 13) and disconnect the casing grounding cable

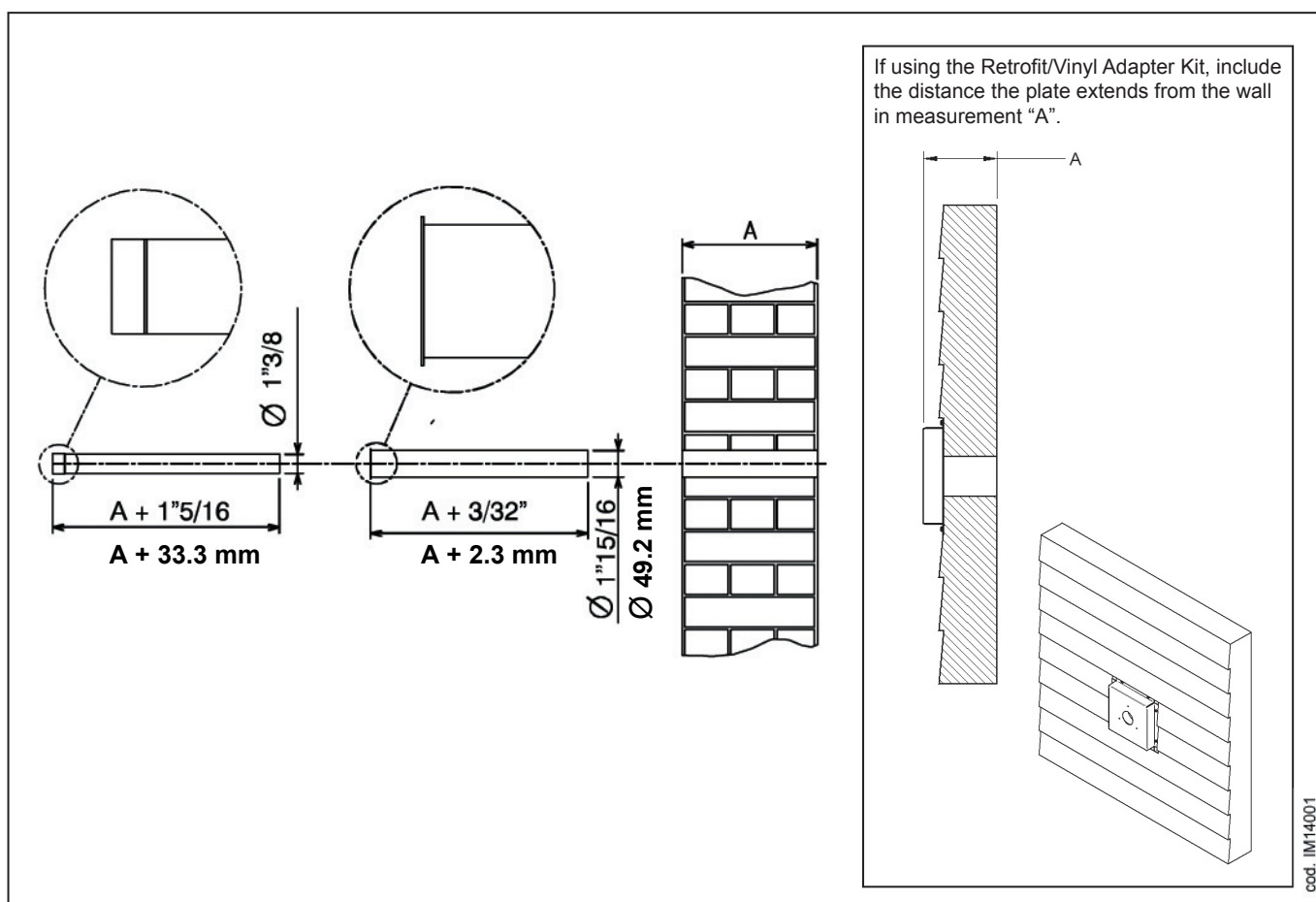

Figure 2 - Pipes cutting (for all models)

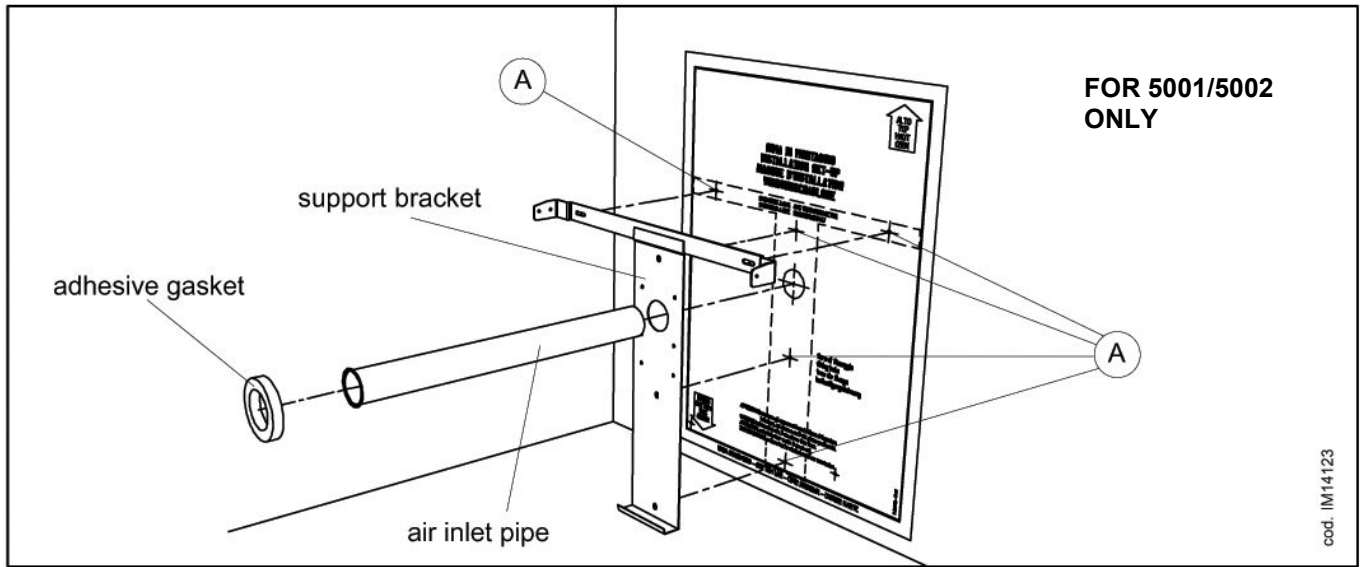

Figure 3 - Positioning of the support bracket (for 5001/5002 only)

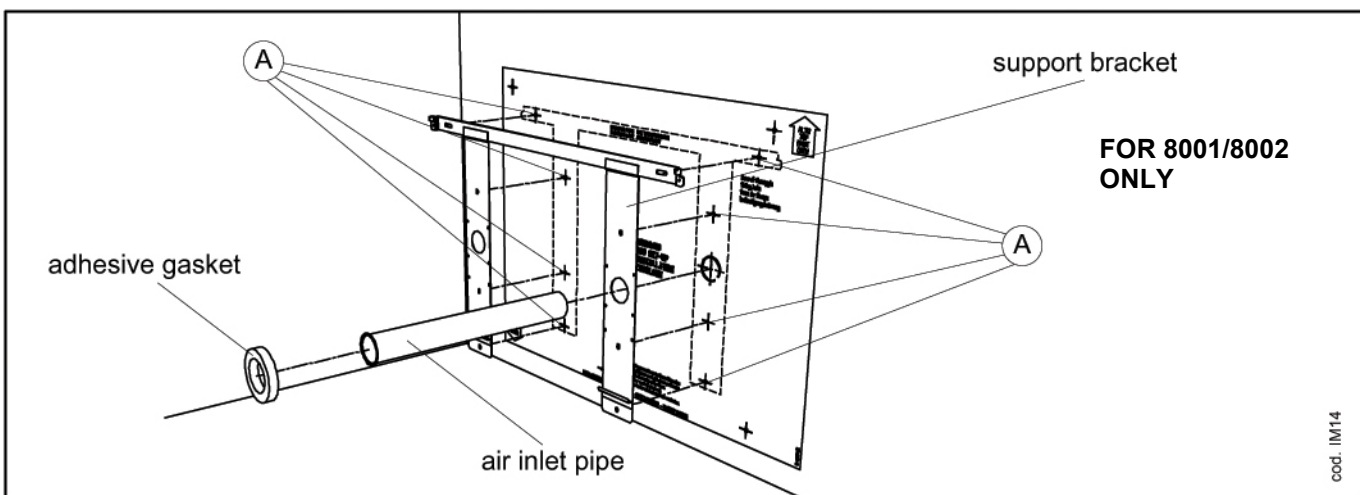
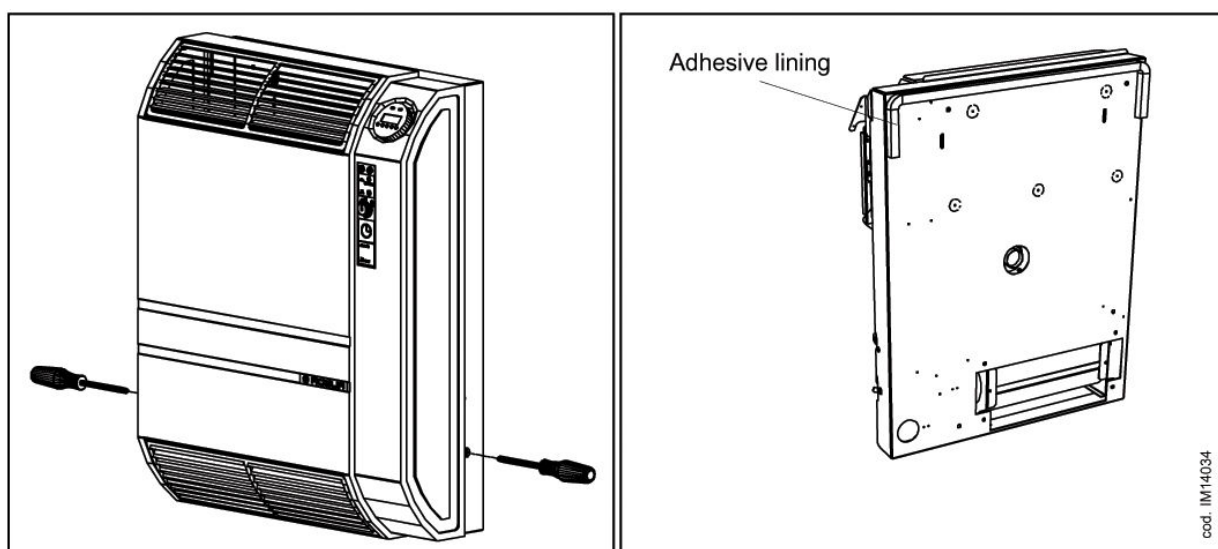
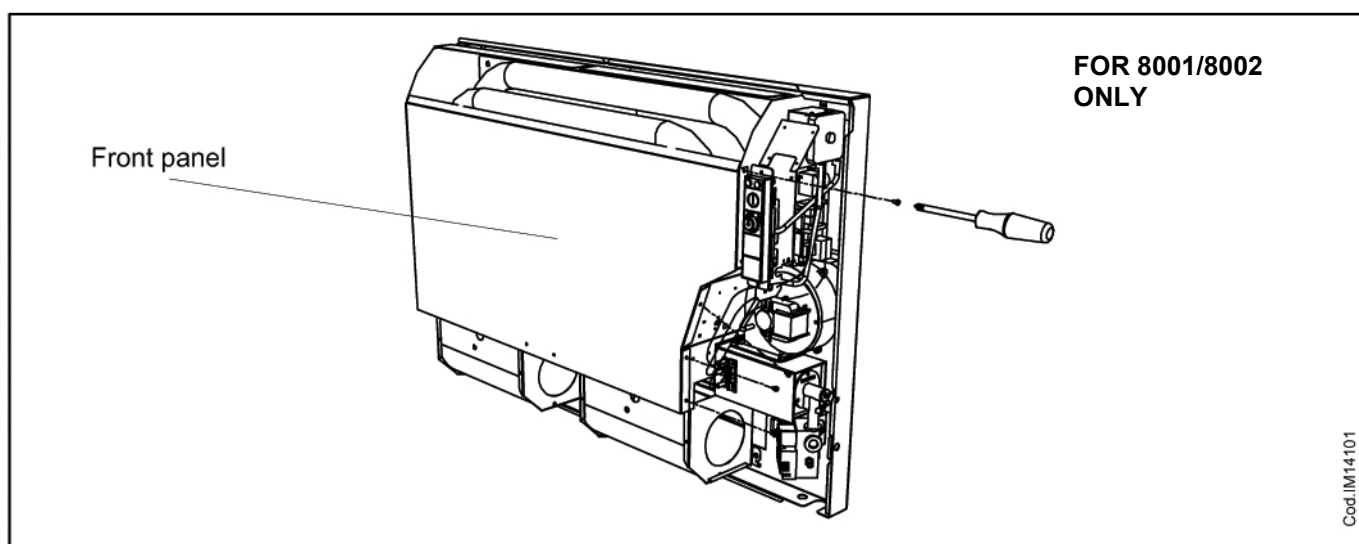

Figure 4 - Positioning of the support bracket (for 8001/8002 only)



**Figure 5** - Fixing screws for external casing (left) and positioning of adhesive spongy lining (right) for all models.



**Figure 6** - Front screen removal (for 8001/8002 only)

8. Place the adhesive spongy lining behind the unit (see Figure 5). Try to do this operation in the proper way the first time and avoid repeated attempts which may be difficult.
9. Fix the flue exhaust flue pipe end (diameter 1" 3/8) on the unit stub pipe female connection (see Figure 7 on page 14). **BE SURE THAT THE RUBBER SYLICONE O-RING GASKET IS IN ITS POSITION.**
10. **FOR 5001/5002 ONLY:** install the unit to the wall leaning the bottom edge of panel C (where the fan is located) on the supporting frame, as indicated in Figure 8 on page 14. Fix the unit to the support bracket by mean of the two lateral screws.
11. **FOR 8001/8002 ONLY:** remove the front panel by unloosening the lateral fixing screws (see Figure 6 above).
12. **FOR 8001/8002 ONLY:** install the unit to the wall leaning the bottom edge of panel C (where the fan is located) on the supporting frame, as shown in Figure 9 on page 15. Fix the unit to the matching hooks A, with a light pressure against the wall (see Figure 9). Install the heating body of the unit to the supporting bracket with the two lateral screws (see reference B in Figure 9).

13. FOR 8001/8002 ONLY: reinstall the front panel.
14. When inside installation is complete proceed with the location of the aluminium vent cap to the external wall. The vent cap should perfectly match the pipe end. Mark the location of the three holes for the screw anchors (see Figure 10 on page 15). The flue grid must be vertical.
15. Remove the vent cap and drill all the necessary holes (diameter 1/4 in. for the screw fittings provided with the unit).
16. Relocate the vent cap and fix it with the screws (see see Figure 10 on page 15).
17. Wire up the unit using a three core cable passing through the correct cable guide with a normal plug and socket.
18. Connect the gas supply line. A gas tap just before each furnace must be installed.
19. Reposition the front panel on 8001/8002 model (see Figure 6 on page 13).
20. Reconnect the grounding wire to the casing and reinstall the casing then tighten the screws.
21. Turn on gas supply and check for gas leaks with soapy water or other suitable means on all gas connections.

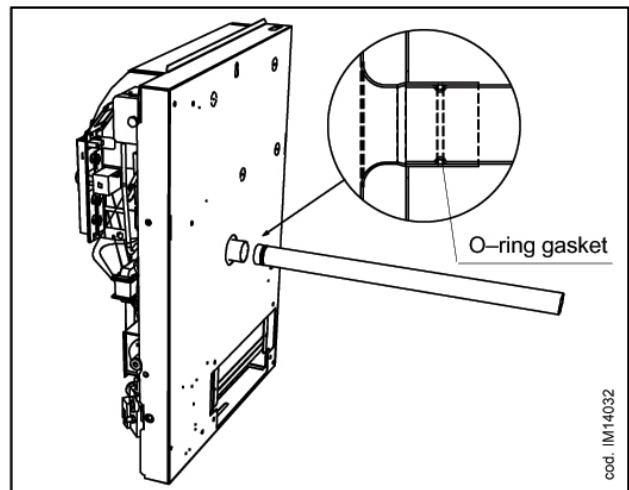

Figure 7 - Positioning of flue exhaust pipe (all models).

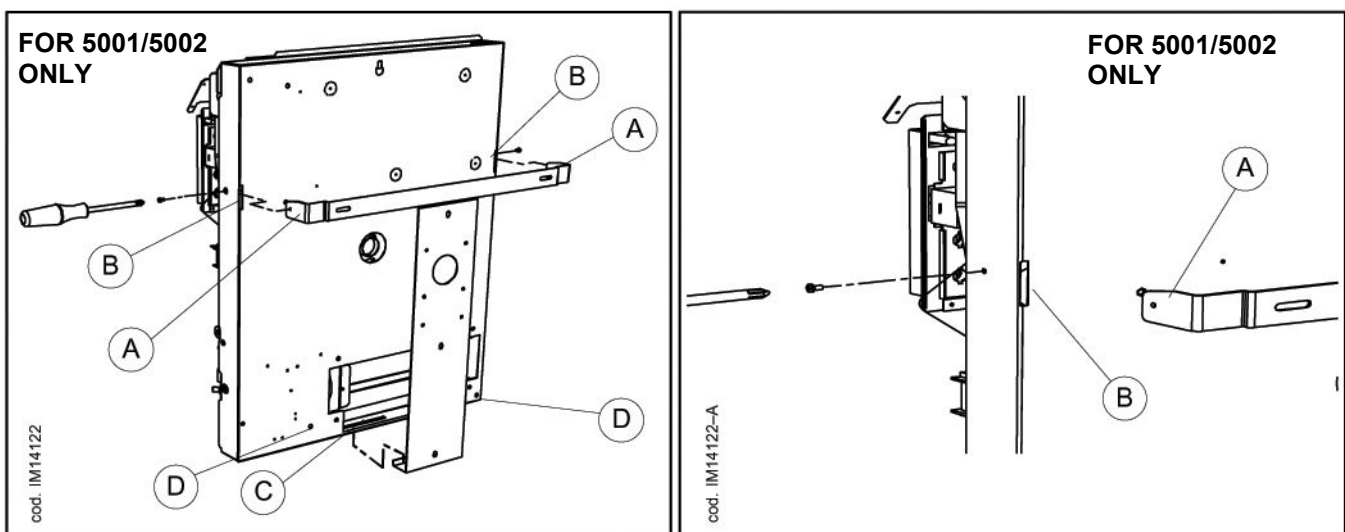
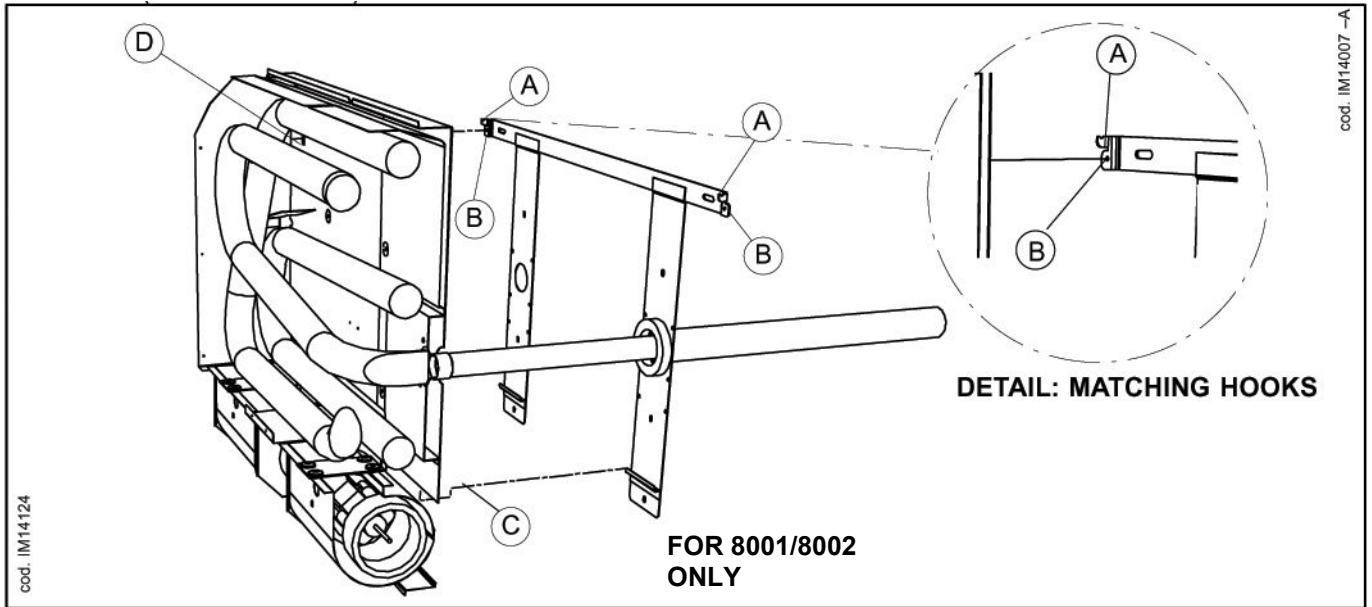
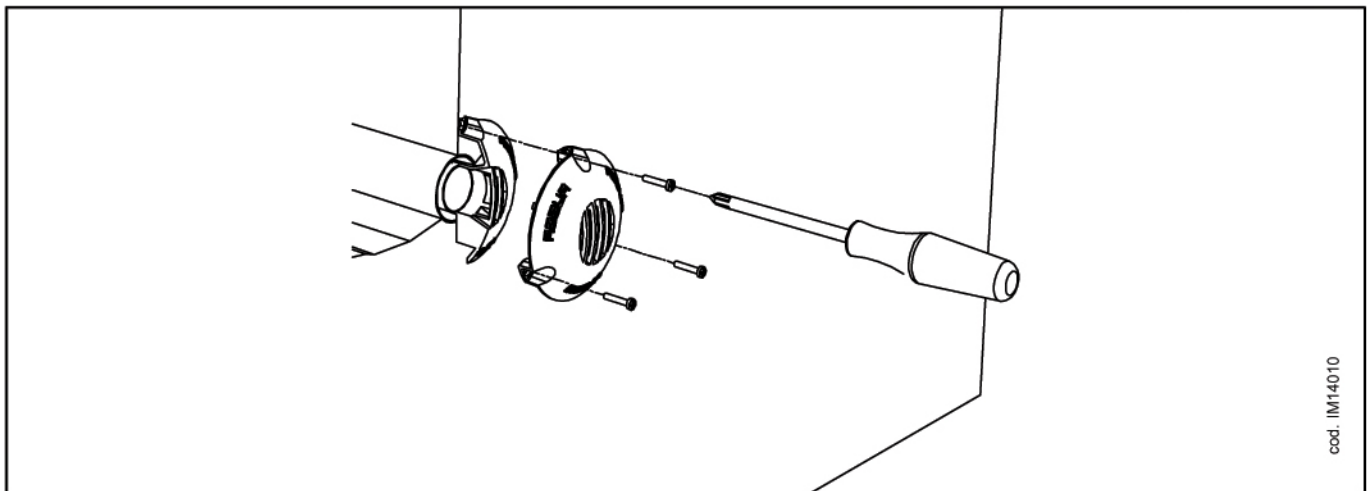

Figure 8 - Hanging of the unit to the supporting bracket and matching hooks (for 5001/5002 only)



**Figure 9** - Hanging of the unit to the supporting bracket and matching hooks (for 8001/8002 only).



**Figure 10** - Installation of the vent cap (all models).

## GAS SUPPLY

Check all local codes for requirements, especially for the size and type of gas supply line required. On Natural gas lines less than 15" (380 mm) long, use 1/2" tube; on longer runs, use 3/4" iron tube or equal. On LP gas lines please consult LP gas supplier.

### INSTALLING A NEW MAIN GAS COCK

Each appliance should have its own manual gas cock. A manual main gas cock should be located in the vicinity of the unit. Where none exists, or where its size or location is not adequate, contact your local authorized installer for installation or relocation.

Compounds used on threaded joints of gas piping shall be resistant to the action of L.P. gas. The gas lines must be checked for leaks by the installer. This should be done with a soap solution watching for bubbles on all exposed connections, and if unexposed, a pressure test should be made.

**Never use an exposed flame to check for leaks. Appliance must be disconnected from piping at inlet of control valve and pipe capped or plugged for pressure test. Never pressure test with appliance connected; control valve will sustain damage!**

A gas valve and ground joint union should be installed in the gas line upstream the gas control to aid in servicing. It is required by the National Fuel Gas Code that a drip line be installed near the gas inlet. This should consist of a vertical length of pipe tee connected into the gas line that is capped on the bottom in which condensation and foreign particles may collect. The use of the following gas connectors is recommended:

- ANSI Z21.24 Appliance Connectors of Corrugated Metal Tubing and Fittings., CGA 6.10.
- ANSI Z21.45 Assembled Flexible Appliance Connectors of Other Than All-Metal Construction.

The above connectors may be used if acceptable by the authorities having jurisdiction.

### PRESSURE TESTING OF THE GAS SUPPLY SYSTEM

1. To check the inlet pressure to the gas valve, a plugged tapping, accessible for

test gauge connection, is provided on the gas valve (see A in Figure 11, page 17).

2. The appliance and its individual shutoff valve must be disconnected from the gas supply piping system during any pressure testing of that system at test pressures in excess of 1/2 psig (3.5 kPa).
3. The appliance must be isolated from the gas supply piping system by closing its individual manual shutoff valve during any pressure testing of the gas supply piping system at test pressures equal to or less than 1/2 psig (3.5 kPa).

**Attention:** If one of the above procedures results in pressures in excess of 1/2 psig (14" w.c.) (3.5 kPa) on the appliance gas valve, it will result in a hazardous condition.

### HIGH ALTITUDES (U.S. ONLY)

For altitudes/elevations above 2,000 feet (610 m), ratings should be reduced at the rate of 4 percent for each 1,000 feet (305 m) above sea level by reducing the manifold pressure at 8% rate on the gas supply.

### HIGH ALTITUDES (CANADA ONLY)

The appliance is tested according to CGA 2.17 M91 for installation between 0 and 4500 ft. (0 and 1370 m) altitude without changes.

### FIRST FIRING OF THE FURNACE

Light up the furnace following the instructions given in section 3 "OPERATING INSTRUCTIONS" on page 21.

The first lighting can be difficult because of the air trapped in the gas lines.

During initial firing of the furnace, residual manufacturing grease will bake out and smoke will occur which is not a health danger. To prevent nuisance and operation of fire alarms, ventilate the room for the first two hours of operation.

### CHECKING THE GAS INLET PRESSURE

The gas inlet pressure can be measured by connecting a test gauge to the connection provided on the gas valve (see A in Figure 11, page 17).

Just after the installation is completed the gas inlet pressure must be checked.

The minimum gas inlet pressure must be as shown in table 1.

After checking the gas inlet pressure disconnect the test gauge and tighten firmly the screw of the gauge connection, then check for gas leaks from it.

### CHECKING THE GAS MANIFOLD PRESSURE

The gas manifold pressure can be measured by connecting a test gauge to the connection provided on the gas valve (see B in Figure 11).

The furnace comes factory-set at the correct manifold gas pressure (see paragraph "TECHNICAL DATA" on page 6).

5002/8002: Just after the installation is completed the gas manifold pressure must be

checked both in Hi and Lo input. 5001/8001: check the pressure on gas input and regulate it by the proper screw protected by a cap; see Figure 11 below.

The gas manifold pressure shall be as shown in "TECHNICAL DATA" on page 6.

Differences of plus or minus 0.1 in. w.c. are accepted.

If the Hi or Lo gas manifold pressures are different from the values given in table 1 for more than 0.1 in. w.c., shut off the furnace and contact your Service Agency.

For instructions about adjustment of the manifold Hi and Lo pressures, see section 4 – Servicing.

After checking the gas manifold pressure, disconnect the test gauge and tighten firmly the screw of the gauge connection, then check for gas leaks from it.

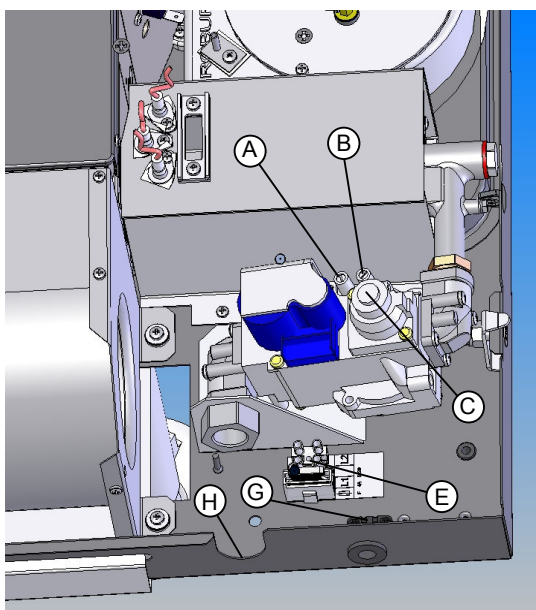

KEY for 5001/8001

- A TEST GAUGE CONNECTION FOR GAS INLET PRESSURE
- B TEST GAUGE CONNECTION FOR GAS MANIFOLD PRESSURE
- C NUT FOR PRESSURE ADJUSTMENT (PRESSURE REGULATOR); THE SCREW IS COVERED BY A CAP
- E ELECTRIC CLAMP CONNECTION
- G ELECTRIC CABLE INLET
- H HOLE FOR GAS SUPPLY INLET

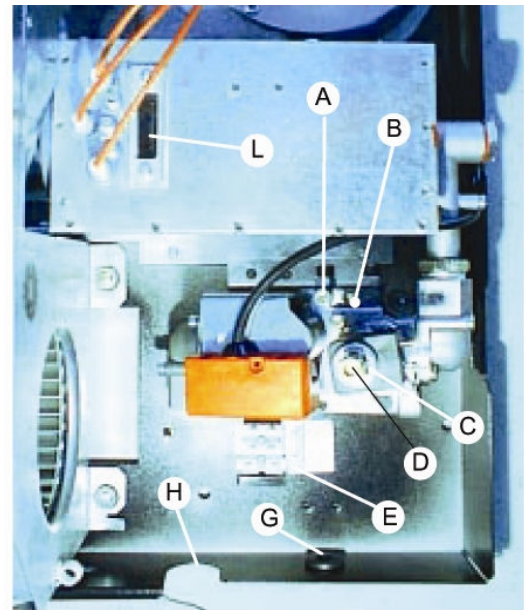

KEY for 5002/8002

- A TEST GAUGE CONNECTION FOR GAS INLET PRESSURE
- B TEST GAUGE CONNECTION FOR GAS MANIFOLD PRESSURE
- C NUT FOR HI PRESSURE ADJUSTMENT (PRESSURE REGULATOR)
- D SCREW FOR LO PRESSURE ADJUSTMENT (HI – LO OPERATOR)
- E ELECTRIC CLAMP CONNECTION
- G ELECTRIC CABLE INLET
- H HOLE FOR GAS SUPPLY INLET
- L FLAME VIEW

Figure 11 - Valve manifold - 5001/8001: LEFT; 5002/8002: RIGHT.

## ELECTRICAL WIRING DIAGRAMS

Here below the wiring diagrams key for all models (the diagrams follow)

EV, EV1	GAS VALVE 1 (SAFETY SHUTTER)	VANNE GAS 1 (SECURITE')
EV2	HI-LO FLAME OPERATOR (*)	OPERATEUR HAUTE-BASSE FLAMME (*)
M	FAN MOTOR (n. 2 MOTORS ON 8001/8002)	MOTEUR DU VENTILATEUR (2 SUR 8001/8002)
M1	OVERHEAT THERMOSTAT	THERMOSTAT DE SURCHAUFFE
M2	FAN THERMOSTAT	THERMOSTAT DE VENTILATION
M9	MAINS FUSE – 5X20 size – 4A	FUSIBLE 5X20 – 4A
NP	PRESSURE SWITCH	PRESSOSTAT DE CIRCUIT DE COMBUSTION
RP8	FLAME SENSOR	ELECTRODE DE DETECTION DE FLAMME
RP7	SPARK IGNITER (n. 2 pcs)	ELECTRODE D'ALLUMAGE
S	COMBUSTION BLOWER MOTOR	MOTEUR DU VENTILATEUR DE COMBUSTION
SF	FLAME VIEW LAMP (GREEN LAMP)	LAMPE DE PRESENCE DE FLAMME (VERTE)
SB	LOCK-OUT LAMP (RED LAMP)	LAMPE DE VERROUILLAGE (ROUGE)
TR	CURRENT TRANSFORMER 120-24 V	TRANSFORMATEUR 120-24 V
Z1	RESET AND SUMMER – WINTER SWITCH (*)	REARMEMENT ET BOUTON ETE' - HIVER (*)
Z2	HI-LO FLAME AND FAN SPEED SWITCH (*)	BOUTON HAUTE-BASSE FLAMME - VITESSE VENTIL. (*)
Z3	MANUAL – PROGRAM MODE SWITCH (*)	BOUTON MANUEL – PROGRAMME' (*)
Z8	PROGRAMMABLE TIMER (*)	INTERRUPTEUR HORAIRE (*)
Z9	ROOM THERMOSTAT	THERMOSTAT D'AMBIANCE
L1	SUPPLY LINE – LIVE WIRE	ALIMENTATION - PHASE
L2	SUPPLY LINE – NEUTRAL WIRE	ALIMENTATION - NEUTRE
GND	SUPPLY LINE – GROUND WIRE	ALIMENTATION - MASSE

**Table 3** - Key for electrical wiring diagrams - (\*) Some functions are only available on 5002 and 8002 models.

### 5001 WIRING DIAGRAM

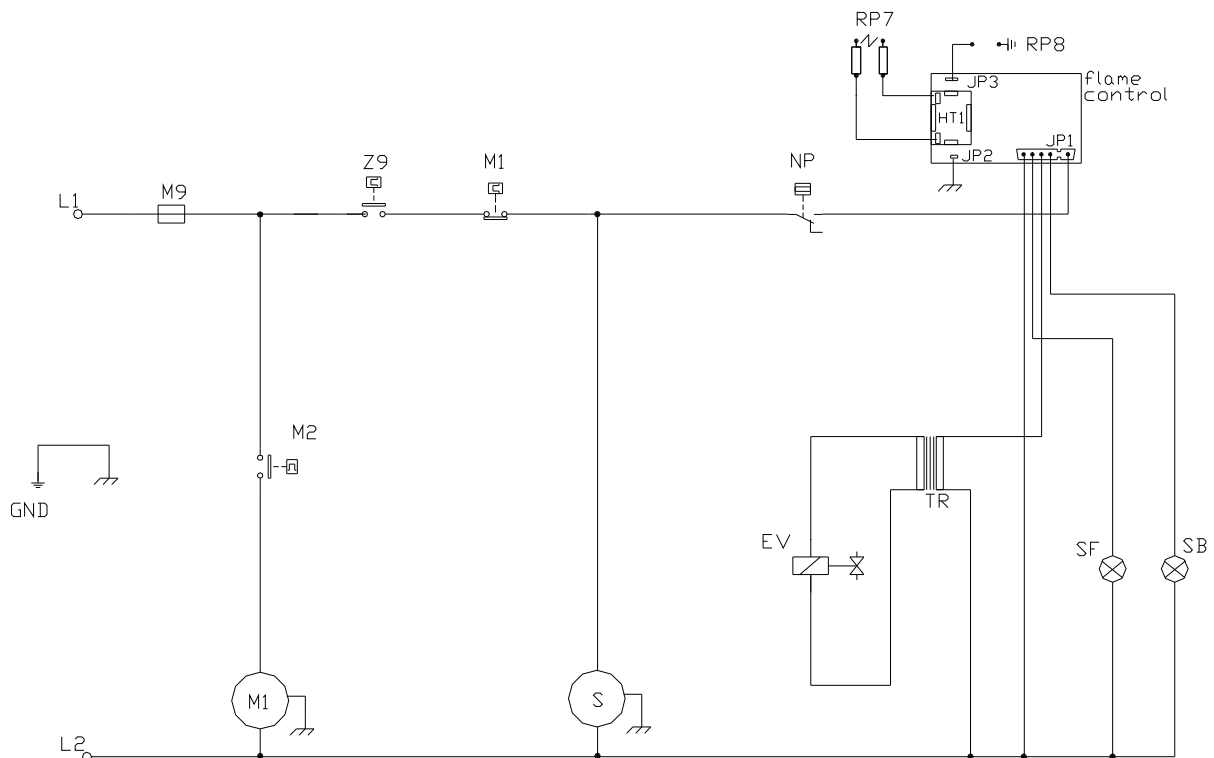

**Figure 12** - 5001 WIRING DIAGRAM

5002 WIRING DIAGRAM

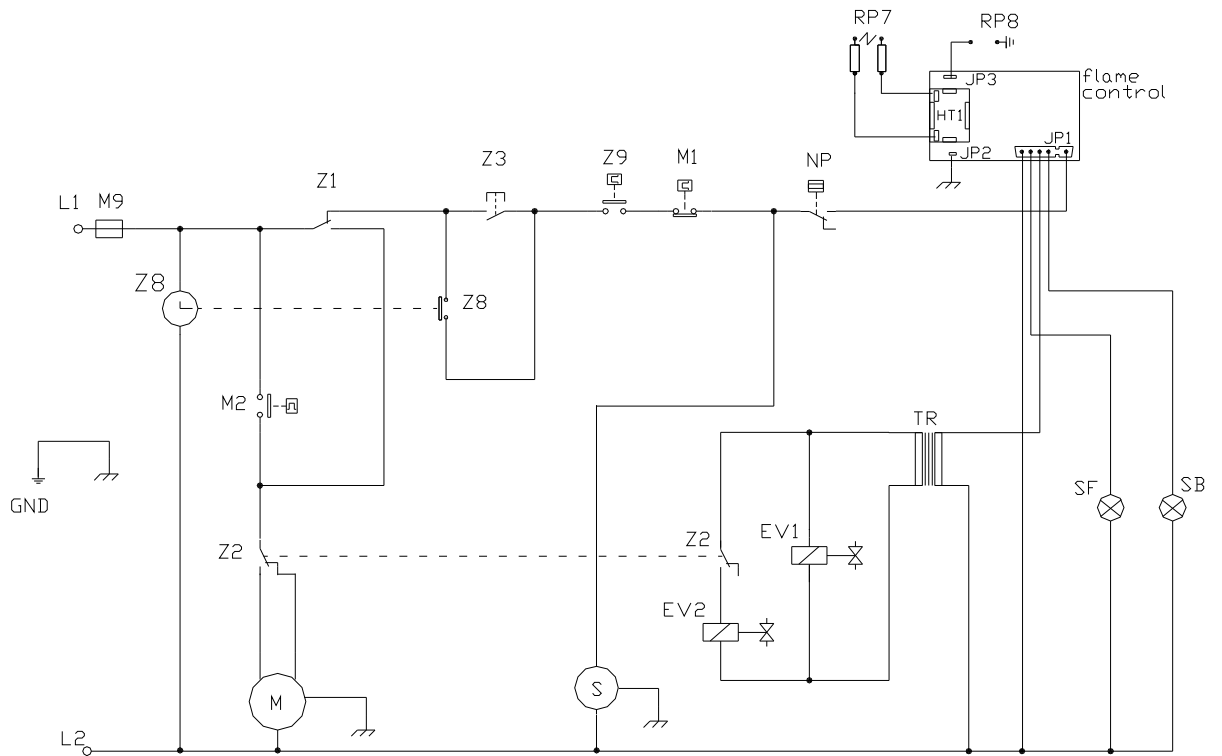

Figure 13 - 5002 WIRING DIAGRAM

8001 WIRING DIAGRAM

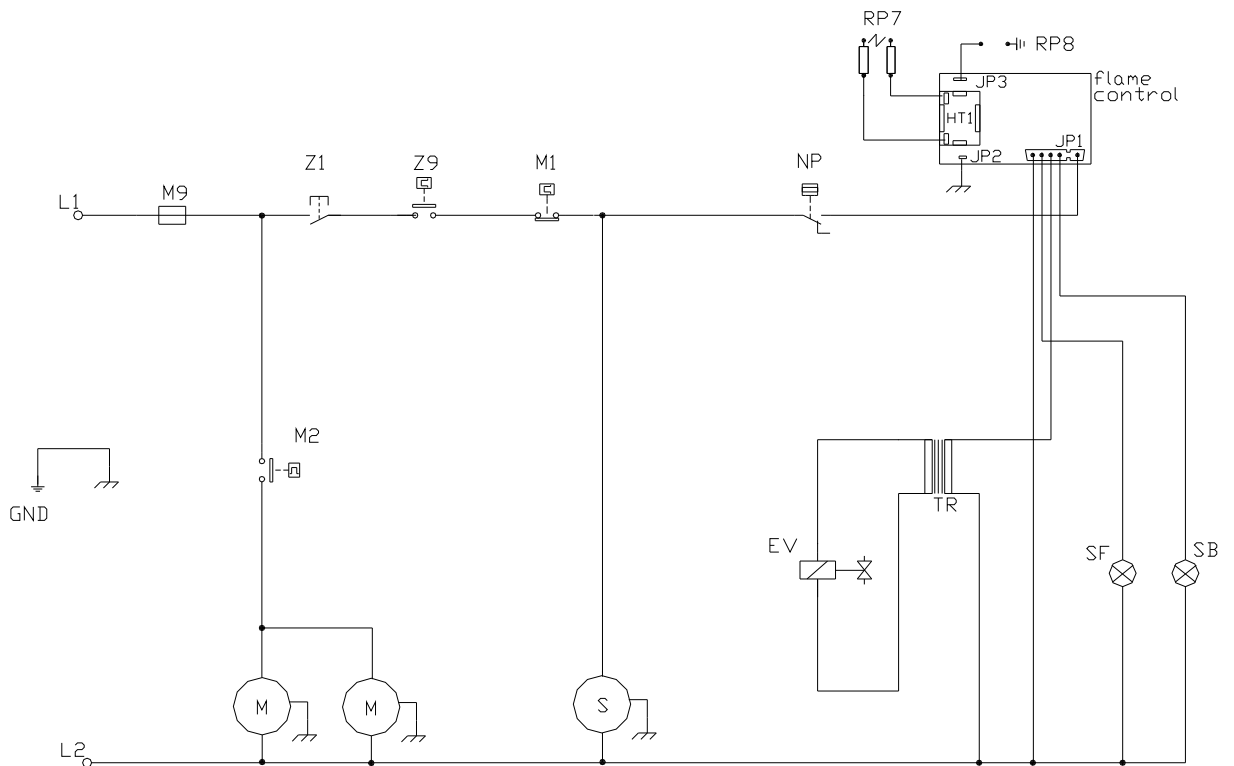

Figure 14 - 8001 WIRING DIAGRAM

8002 WIRING DIAGRAM

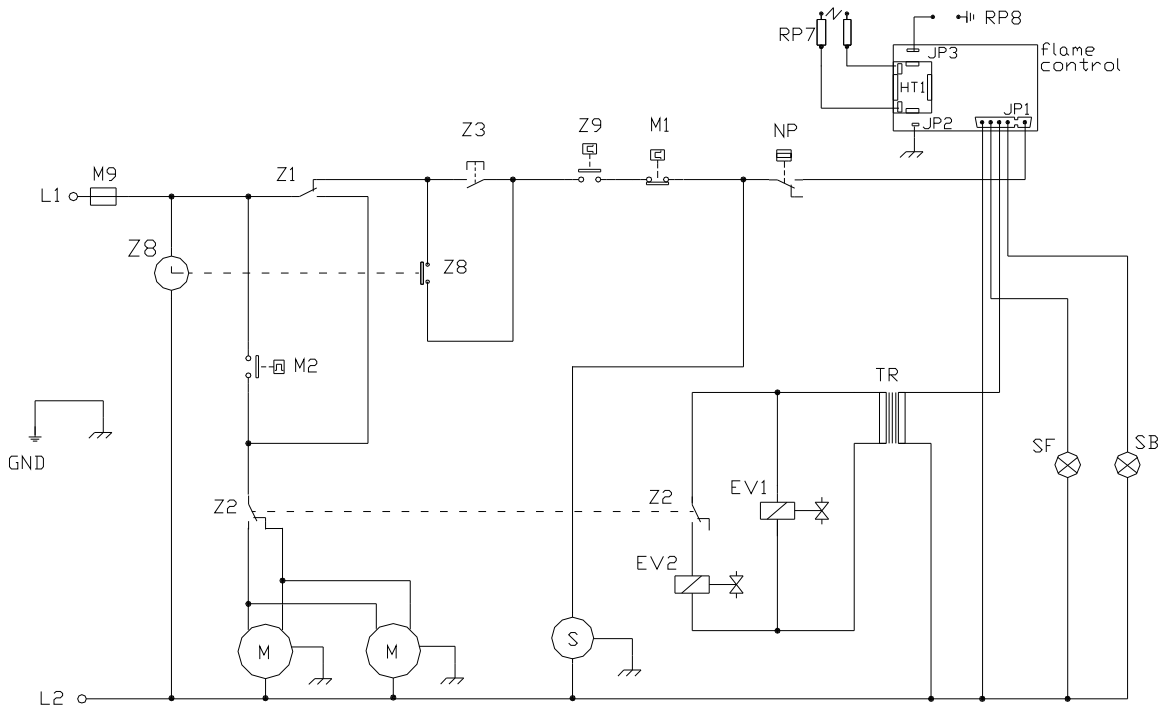

Figure 15 - 8002 WIRING DIAGRAM

## SECTION 3 OPERATING INSTRUCTIONS

Before operating the furnace, read carefully all warnings and safety information on pages 4 and 5 of this manual.



### OPERATING INSTRUCTIONS FOR MODELS 5001 and 8001

#### FOR YOUR SAFETY READ BEFORE OPERATING

**WARNING:** If you do not follow these instructions exactly, a fire or explosion may result causing property damage, personal injury or loss of life.

- |   |   |
|---|---|
| <p>A. This appliance does not have a pilot. It is equipped with an ignition device which automatically lights the burner. Do <u>not</u> try to light the burner by hand.</p> <p>B. <b>BEFORE OPERATING</b> smell all around the appliance area for gas. Be sure to smell next to the floor because some gas is heavier than air and will settle on the floor.</p> <p><b>WHAT TO DO IF YOU SMELL GAS:</b></p> <ul style="list-style-type: none"> <li>- Do not try to light any appliance</li> <li>- Do not touch any electric switch; Do not use any phone in your building</li> <li>- Immediately call your gas supplier from a neighbour's phone.</li> </ul> | <p>Follow the gas supplier's instructions.<br/>- If you cannot reach your gas supplier, call the fire department.</p> <p>C. Use only your hand to push in or turn the gas control knob. Never use tools. If the knob will not push in or turn by hand, don't try to repair it, call a qualified service technician. Force or attempted repair may result in a fire or explosion.</p> <p>D. Do not use this appliance if any part has been under water. Immediately call a qualified service technician to inspect the appliance and to replace any part of the control system and any gas control which has been under water.</p> |
|---|---|

#### OPERATING INSTRUCTIONS

1. **STOP!** Read the safety information above on this label.
  2. Set the thermostat to the lowest setting by turning it counterclockwise  completely. Do not force.
  3. Turn off all electric power to appliance.
  4. This appliance is equipped with an ignition device with automatically lights the burner. Do not try to light the burner by hand.
  5. Turn off gas supply to the unit by turning off the gas tap.
  6. Wait (5) minutes to clear out any gas. If you then smell gas, **STOP!** Follow "B" in the safety information above on this label. If you don't smell gas, go to the next step.
  7. Turn on gas supply to the unit.
  8. Turn on electric power to the appliance.
  9. Set the thermostat to the highest setting by turning it clockwise  completely. Do not force.
  10. The red lamp will be alight for 40 seconds, then the flame will light up. The red lamp will then shut off and the green one will be alight.
  11. Set thermostat to desired setting.
  12. If the appliance will not operate, follow the instructions "To Turn Off Gas Of Appliance" and call your service technician or gas supplier.
  13. This appliance has an automatic flame control system. When the flame is alight, the green lamp is alight too. In case of flame fault, the red lamp will light up and the green one will turn off. If this occurs, press the reset button.
- The appliance will perform a new lighting attempt after about 40 seconds. During these 40 seconds the red lamp will be alight. If this new attempt is unsuccessful, turn off electric power to the appliance and call your Service Agency.

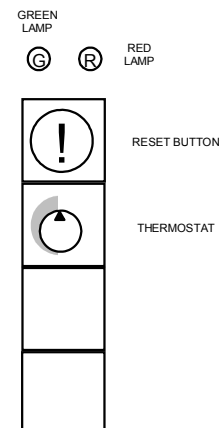

#### TO TURN OFF GAS TO APPLIANCE

1. Set the thermostat to the lowest setting by turning it counterclockwise  completely. Do not force.
2. Turn off all electric power to the appliance if service is to be performed.
3. Turn the gas tap installed on the gas supply to the CLOSED position.

## OPERATING INSTRUCTIONS FOR MODELS 5002 and 8002

### FOR YOUR SAFETY READ BEFORE OPERATING

**WARNING:** If you do not follow these instructions exactly, a fire or explosion may result causing property damage, personal injury or loss of life.

- A. This appliance does not have a pilot. It is equipped with an ignition device which automatically lights the burner. Do not try to light the burner by hand.
- B. **BEFORE OPERATING** smell all around the appliance area for gas. Be sure to smell next to the floor because some gas is heavier than air and will settle on the floor.
- WHAT TO DO IF YOU SMELL GAS:**
- Do not try to light any appliance
  - Do not touch any electric switch; Do not use any phone in your building
  - Immediately call your gas supplier from a neighbour's phone.
- C. Use only your hand to push in or turn the gas control knob. Never use tools. If the knob will not push in or turn by hand, don't try to repair it, call a qualified service technician. Force or attempted repair may result in a fire or explosion.
- D. Do not use this appliance if any part has been under water. Immediately call a qualified service technician to inspect the appliance and to replace any part of the control system and any gas control which has been under water.
- Follow the gas supplier's instructions.  
- If you cannot reach your gas supplier, call the fire department.

### OPERATING INSTRUCTIONS

1. **STOP!** Read the safety information above on this label.
2. Set the thermostat to the lowest setting by turning it counterclockwise  completely. Do not force.
3. Turn off all electric power to appliance.
4. This appliance is equipped with an ignition device with automatically lights the burner. Do not try to light the burner by hand.
5. Turn off gas supply to the unit by turning off the gas tap.
6. Wait (5) minutes to clear out any gas. If you then smell gas, **STOP!** Follow "B" in the safety information above on this label. If you don't smell gas, go to the next step.
7. Turn on gas supply to the unit.
8. Turn on electric power to the appliance.
9. Push the MIN/MAX button to MIN (button down).
10. Switch the SUMMER/WINTER button to WINTER (button up).
11. Set thermostat to desired setting.
12. The red lamp will be alight for 40 seconds, then the flame will light up. The red lamp will then shut off and the green one will be alight.
13. If the appliance will not operate, follow the instructions "To Turn Off Gas Of Appliance" and call your service technician or gas supplier.
14. If you choose the high heat output (quick heating), push the MIN/MAX button to MAX (button up). If you prefer soft heating and silent operation, keep it on MIN (button down).
15. This appliance has an automatic flame control system. When the flame is alight, the green lamp is alight too. In case of flame fault, the red lamp will light up and the green one will turn off. If this occurs, turn the SUMMER/WINTER button to SUMMER (button down) and wait ten (10) seconds; then turn the switch back to WINTER (button up).  
The appliance will perform a new lighting attempt after about 40 seconds. During these 40 seconds the red lamp will be alight. If this new attempt is unsuccessful, turn off electric power to the appliance and call your Service Agency.

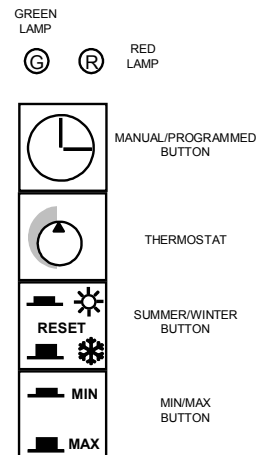

### TO TURN OFF GAS TO APPLIANCE

1. Set the thermostat to the lowest setting by turning it counterclockwise  completely. Do not force.
2. Turn off all electric power to the appliance if service is to be performed.
3. Turn the gas tap installed on the gas supply to the CLOSED position.

## WHAT TO DO IF THE RED LAMP LIGHTS UP (ALL MODELS)

This appliance has an electronic flame supervision device. If the flame disappears the gas flow will be automatically shut off and the red lamp will alight instead of the green one. The appliance will perform a new lighting attempt if you do **ONE** of the following actions:

- A. Turn off all electric supply to the appliance for some seconds then turn it on again; **OR**
- B. Turn the thermostat knob to zero setting, then turn it back to comfort setting after some seconds; **OR**
- C. Press the reset button once (5001/8001 models), or press the SUMMER/WINTER button to SUMMER (button down) for some seconds, then push it back (button up) to WINTER position (5002/8002 models).

## HOW TO SHUT OFF THE APPLIANCE

1. Turn the thermostat knob to the ZERO position.
2. Turn the I-O switch on the programmable clock to ZERO position.
3. Turn off all electric supply to the appliance.
4. Turn the gas tap installed on the gas supply line upstream to the unit to **CLOSED** position.

## USING YOUR 5001/8001 HEATER

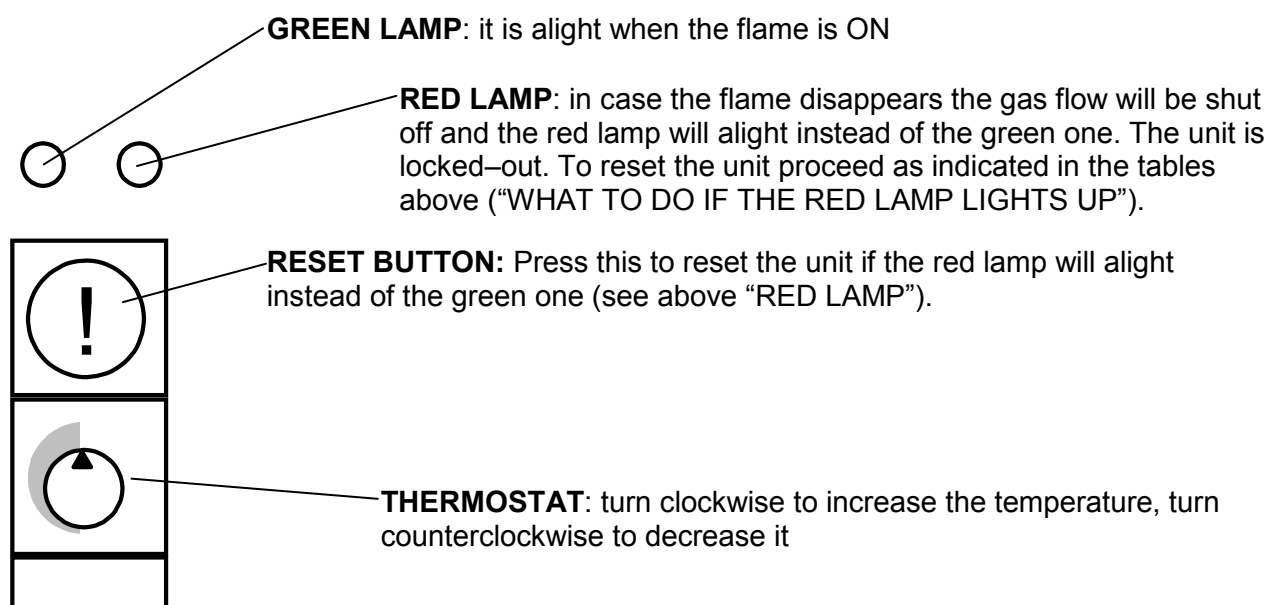

## USING ALL THE FEATURES OF YOUR 5002/8002 HEATER

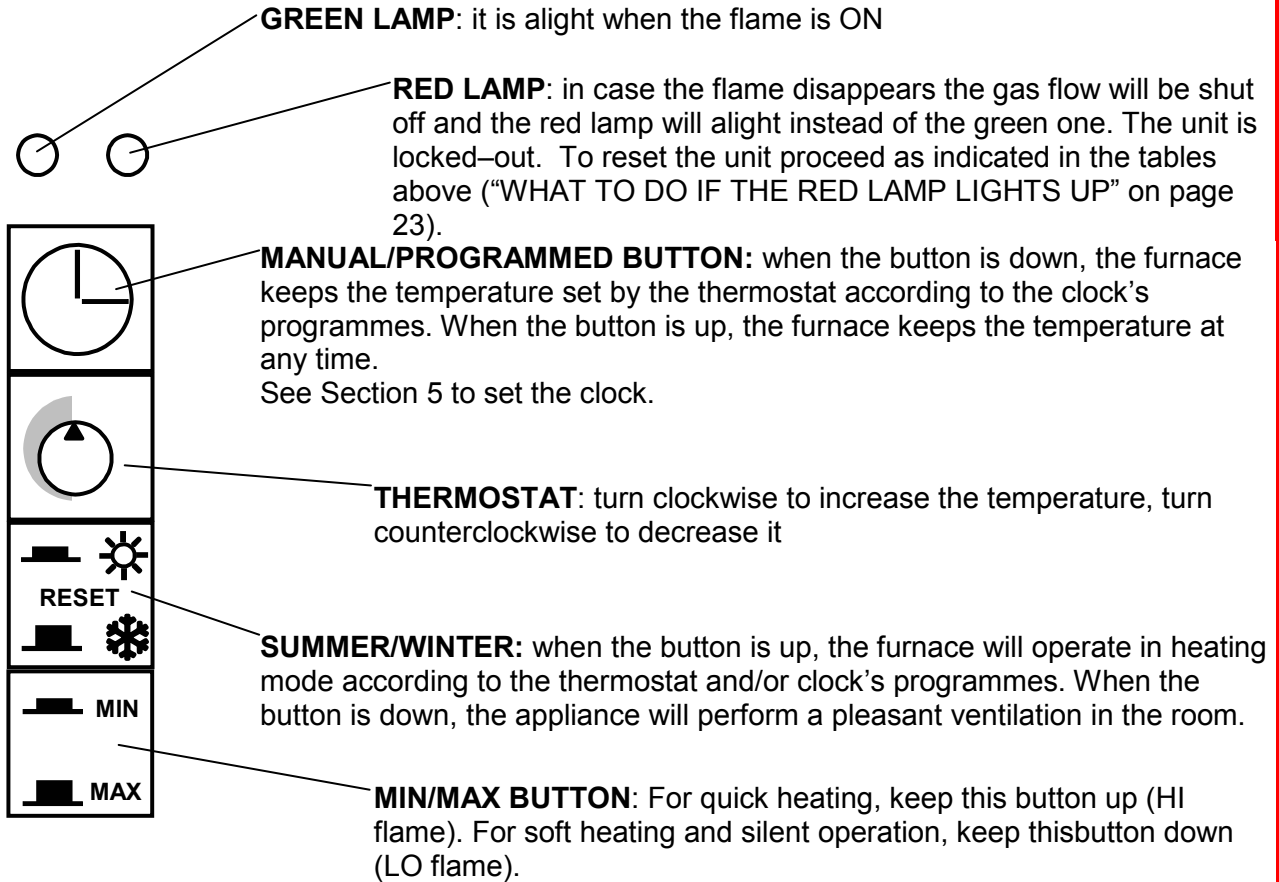

**HUMIDIFIER:** For better comfort the 5002 and 8002 heaters are equipped with a humidifier. Its use is very easy. It is enough to periodically fill in (by means of a funnel) the small tank located on the left side of the unit (see figure). Normally, the tank needs to be refilled after 4–5 days.

NOTE: the use of water low in limestone is advisable (possibly use distilled water) in order to prevent any possible calcareous sedimentation that may be difficult to remove.

Also anticalcareous tablets for humidifiers are commercially available. The humidifier capacity is 11.8 fl.oz. (0.35 l).

HUMIDIFIER: water filling hole

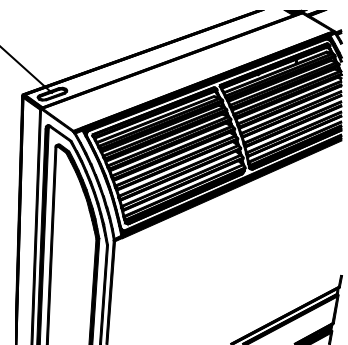

## SECTION 4    SERVICING

All servicing activities must be carried out by a qualified installer or a Service Agency only.

The user may not service the appliance. The user must read this section just to be informed of the periodical checks the unit requires.

All servicing operations (except on vent system) must be carried out with the external casing removed (see "INSTALLATION" on page 9).

After any service operation, the external casing must be reinstalled properly and the grounding wire of the external casing reconnected.

### CHECKING AND ADJUSTING THE GAS MANIFOLD PRESSURE

5002/8002: the appliance comes factory – set at the correct HI and LO gas manifold pressures as shown in "TECHNICAL DATA" on page 6. It is recommended to check the pressures periodically (minimum once an year): see instructions in "INSTALLATION" on page 9.

If after checking an adjustment is needed, this can be done by means of the nut C and screw D (Figure 11 in SECTION 2, page 17). A test gauge must be connected as explained in SECTION 2, paragraph "CHECKING THE GAS MANIFOLD PRESSURE" on page 17. Proceed as follows:

1. Switch the unit on in HI mode (button MAX–MIN up).
2. Screw down completely the screw C (HI – LO operator adjustment) until end of stroke, by turning it clockwise. Do not force.
3. Adjust the HI pressure by turning the screw D (pressure regulator) to the value given in table 1. Turn clockwise to increase the

pressure, turn counterclockwise to decrease it.

4. Switch the unit to LO mode (button MAX–MIN down).
5. Unscrew the screw C until the correct value for the LO pressure is achieved.
6. Switch the unit from LO to HI mode some times to check that both the HI and LO pressures are correct. A tolerance of plus or minus 0.1 in. w.c. on the pressure values is acceptable. Re – adjust starting from point 1. if needed.
7. Disconnect the test gauge and tighten firmly the screw of the gauge connection, then check for gas leaks from it.

The HI and LO pressures must be adjusted in the way explained above. Never try to adjust them independently from each other.

5001/8001: adjust the manifold pressure by rotating the regulation screw clockwise to increase the pressure, counterclockwise to decrease it. The regulation screw is protected by a cap (see Figure 11 on page 17).

### CHECKING, REMOVING AND REASSEMBLING OF THE VENT – AIR INTAKE SYSTEM

It is essential that the vent – air intake system is examined periodically (minimum once an year) to verify it is clean from dust and deposits of solid materials like leaves or also small animals (insects) which could build their nest in the flue or air pipe, especially in springtime.

The vent – air intake system is checked from outside.

Proceed as follows:

1. Remove the vent cap by removing the three outer screws (see Figure 10 on page 15).

2. Remove the flue pipe, i.e. the inner one. Do not use tools: the pipe can be extracted by hand with a moderate effort.
3. Check for cleanliness the vent cap, the flue pipe and the air pipe **which may not be removed from outside**. Remove dust and deposits from the pipes. Deposits in the air pipe must be taken outside: do not push them towards the unit.
4. Check the O–Ring gasket in the flue pipe. If it is damaged replace it (part n. N–GRG005).

5. Reinstall the flue pipe from outside. Do not use glue or sealants: the gasket ensures complete seal of the connection.

6. Reinstall the vent cap on the flue pipe. Do not use glue or sealants. Tighten the three outer screws.

### **LUBRICATION OF MOVING PARTS**

The only moving parts of the unit are the electric motors, which are lubricated for life and thus do not require lubrication.

Do not try to lubricate any part of the appliance like motors bearings, keys, knobs, screws, etc.

### **FLAME VISUAL CHECK**

Correct and proper operation of the burner may be checked from the aspect of the flame. Check the flame any time the external casing is removed for any reason.

The flame may be examined through the flame view L (see Figure 11 in SECTION 2, page 17). The flame must be stable and have blue color. Some small yellow tips are acceptable with propane gas.

If the flame is yellow or has excessive turbulence, check the gas manifold pressure and the vent-air intake system as described above. If all these are verified to be regular, call the Service Agency for a complete check of the unit. Call also your gas supplier to check the composition of the gas in use.

## SECTION 5 PROGRAMMABLE TIMER

The programmable timer (Figure 16 below) allows precise operating and timing control. The programmable timer is supplied as a standard with 5002 and 8002 units, and as an optional on 5001 and 8001 units.

### OVERVIEW

The programmable timer has the following characteristics:

- Long life lithium battery
- Daily and weekly program
- Minimum switching time: 1 minute
- Quick progression: keeping pushed any setting key, the progression is quick until the button is released.
- Choice of programmes: 16 (8 for on – 8 for off)
- Days of the week and hours of the day selection
- Programmable day blocks:
 

1–2–3–4–5	(Mon–Fri)
1–2–3–4–5–6	(Mon–Sat)
1–2–3–4–5–6–7	(Mon–Sun)
6–7	(Sat–Sun)

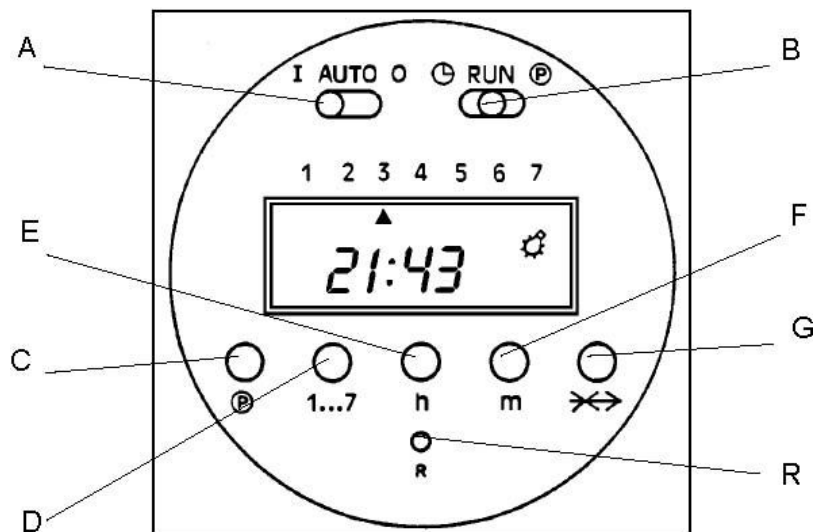

**KEY**

<p>A ON/OFF SWITCH</p> <p>B SETTING / REGULATION SWITCH</p> <p>C Program selection</p> <p>D Day selection</p> <p>E Hours setting</p>	<p>Pos. I The appliance is controlled by the room thermostat</p> <p>Pos. AUTO The appliance is controlled by both the timer and the room thermostat</p> <p>Pos. O The appliance is turned off</p> <p>Pos. ⊕ Time setting</p> <p>Pos. RUN Normal operation mode (the display shows the current time)</p> <p>Pos. ⊕ Setting of programming</p> <p>F Minutes setting</p> <p>G SKIP button (skip the actual program)</p> <p>R Reset button</p>
--	--

**Figure 16** - Programmable timer

## SETTING AND ADJUSTMENT

### INITIAL CONDITIONS

A. Make sure that the B selector is in RUN position. After pressing the reset button R, the display starts flashing.

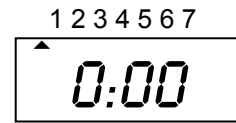

B. With the selector in  $\textcircled{P}$  position, after pressing the reset button, the notice of error EEE will appear on the display. Move the B selector to the RUN position: the notice will disappear; then reset the system.

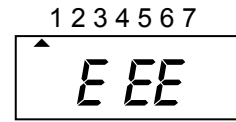

C. If the selector B is moved to  $\textcircled{C}$  position the indication on the display is fix.

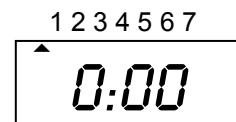

D. If the selector B is moved to RUN position the indication on the display is fix with the colon flashing.

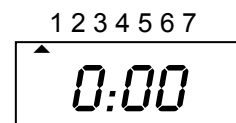

E. If the selector is moved to  $\textcircled{P}$  position, the indication on the display is flashing: the symbols  $\odot$ , 1,  $\uparrow$  will appear.

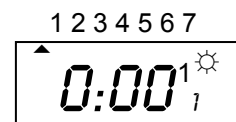

### MANUAL OPERATING DEVICE

Move the A left selector to position I.

- The symbol of a light ( $\odot$ ) will appear on the display. In this condition the heater is controlled by the room thermostat and is independent from the programmes which are set on the timer.

Move the A selector to position O.

- The symbol of the light ( $\odot$ ) on the display will disappear. In this condition the heater is deactivated (off).

Move the A selector to AUTO position.

- The programmes function is activated. The operation of the unit now depends on the preset programmes. The heater is controlled both by the timer and by the room thermostat.

TIME SETTING

Example: Set Wednesday, 15.16 hours.

- A. The selector B is to be moved to ⊖ location.
- B. Set the day of the week. Press the day key 1....7, the triangular shaped indicator proceeds one unit at a time. Number 1 stands for Monday, number 2 stands for Tuesday, etc.
- C. Set the time (hours and minutes). To have 15.16 hours, press “h” key for the hours and “m” button for the minutes. Pressing the button once the movement is slow (one digit at a time). If the button is depressed for more than two seconds the movement is fast until the button is released.
- D. After setting the day and the time move the right selector (detail B) to RUN: the indication on the display is fix with the colon flashing.

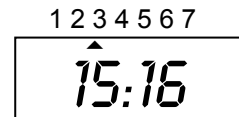
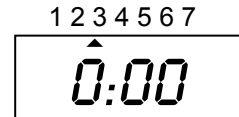

PROGRAMMING THE TIMER

NOTE: 16 different switchings can be programmed on the timer:

- 8 for “ON” (1-3-5-7-9-11-13-15) which are shown by a light on the right end of the display
- 8 for “OFF” (2-4-6-8-10-12-14-16)

- A. Move the selector B to ⊕ position. On the right side of the display the number 1, 1 and the symbol of the light will appear, indicating that the ON switching time is to be set
- B. Press the day 1.....7 button to set the day or the block of days during which the switching ON is required (no. 2 stands for Tuesday, etc.) To set the desired ignition time press the h button for the exact hour and the m button for the exact minutes (for example 09.03). Pressing one of the two buttons, the indication on the display will slowly progress. Keeping the button depressed for more than 2 sec the progression is fast until the button is released.
- C. Press the ⊕ button (see Figure 16 on page 27). On the right side of the display will appear number 2 without the light symbol indicating that the OFF switching time is to be set.
- D. Press the 1...7 button to programme once again the same day or block of days previously selected for programme n. 1 (switch ON). To set the OFF time press button h and m (in the example 11.04 hours).
- E. To set further programmes repeat the same operations from item b) to d).

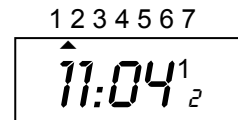
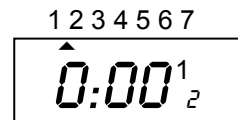
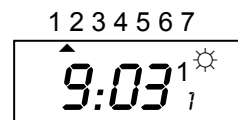
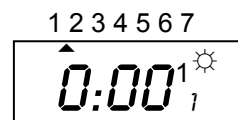
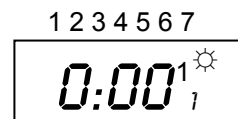

NOTE: where the same ON and OFF time is required for different days of the week, the setting procedure can be simplified:

- 1-2-3-4-5 (from Mon through Fri)
- 1-2-3-4-5-6 (from Mon through Sat)
- 1-2-3-4-5-6-7 (from Mon through Sun)

- 6-7 (Sat and Sun)

F. When all setting operations have been carried out, check and ensure that the different programmes do not contrast many times one with the others in order to avoid undesired operations. You can check on the display the different settings (programmes) by simply pressing button  $\textcircled{P}$  many times.

G. Move selector B to RUN position. The display will show the current day and time.

WARNING: all the programmes set will be activated ONLY the day after the setting has been carried out.

During operation, the ON status of the timer is shown on the display by a light on the right end. When the light does not appear, it means that the timer is in OFF status.

### DELETING OF THE SINGLE PROGRAM

To delete the single program proceed as follows:

- Move the right selector to the position  $\textcircled{P}$ . Press the  $\textcircled{P}$  and choose the programme to be cancelled.
- Press simultaneously key  $\textcircled{P}$  and key  $\times \rightarrow$  (SKIP) for least 2 sec. and selected program will be cancelled.
- Indication that program is cancelled is continued blinking of 0:00.

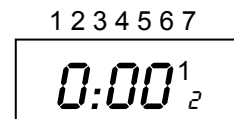

### DELETING OF ALL PRE-SET PROGRAMS

To cancel all the pre-set programs press the key "R" for at least 2 seconds. All the pre-set programs will be cancelled.

### SETTING OF SKIP FUNCTION (SKIP THE ACTUAL PROGRAM)

To skip the actual program proceed as follows:

- Put the right selector in "RUN" position.
- Press  $\times \rightarrow$  key to SKIP the actual program. The next program will be activated when required. SKIP function is shown on display by the symbol of a crossed arrow (see SKIP symbol in Figure 16 on page 27).
- The SKIP command can be stopped in any moment, by pressing again the  $\times \rightarrow$  key. The pre-set program will restart and SKIP symbol will disappear from the display.

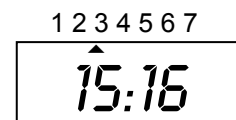
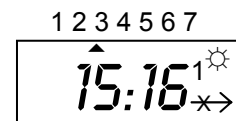

### SKIP FUNCTION PROCEDURE DURING OPERATION

- SKIP function can be activated only in "RUN" mode.
- SKIP function starts immediately after the pressing of the key, and disappears when next program starts.
- SKIP function can be stopped manually by pressing the SKIP key. In this case the pre-set program will be activated.



## **EuroTherm** *Systems*

100 Quaker Lane • Malvern, PA 19355

Phone: 610-240-4900

Fax: 610-240-4906

[www.eurothermsystems.com](http://www.eurothermsystems.com)