

Owner's Operation and Installation Manual for the



# EX17 (RHFE-433RWT)

# EX22 (RHFE-558RWT)



Energysaver<sup>®</sup>

Gas Direct Vent Wall Furnace

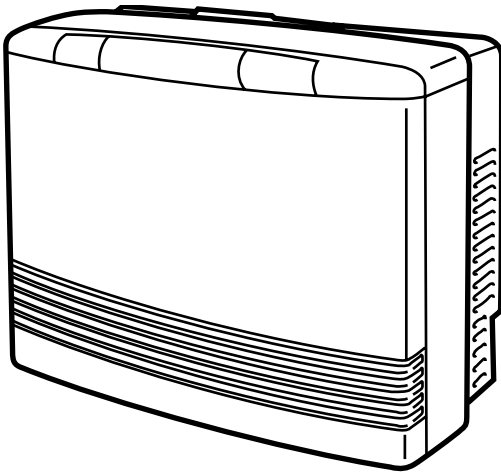

Table of Contents .....	2
Safety Information .....	3
Operating Instructions ...	9
Care and Maintenance ...	22
Fault Codes .....	25
Installation Instructions...	26
Parts List .....	44
Consumer Support .....	50

**WARNING:** If the information in these instructions is not followed exactly, a fire or explosion may result causing property damage, personal injury or loss of life.

- Do not store or use gasoline or other flammable vapors and liquids in the vicinity of this or any other appliance.
- **WHAT TO DO IF YOU SMELL GAS**
  - Do not try to light any appliance.
  - Do not touch any electrical switch; do not use any phone in your building.
  - Immediately call your gas supplier from a neighbor's phone. Follow the gas supplier's instructions.
  - If you cannot reach your gas supplier, call the fire department.
- Installation and service must be performed by a qualified installer, service agency or the gas supplier.

**Rinnai<sup>®</sup>**

**INSTALLER:** Leave this manual with the appliance.  
**CONSUMER:** Retain this manual for future reference.

This appliance may be installed as an OEM installation in a manufactured home (USA only) or mobile home and must be installed in accordance with the manufacturer's instructions and the *Manufactured Home construction and Safety Standard, Title 24 CFR, Part 3280*, in the United States, or the *Mobile Home Standard, CAN/CSA Z240 MH Series*, in Canada. This appliance is only for use with types of gas indicated on the rating plate. A conversion kit is supplied with the appliance.

This appliance may be installed in an aftermarket, permanently located, manufactured home (USA only) or mobile home, where not prohibited by local codes.

This appliance is only for use with the type of gas indicated on the rating plate. This appliance is not convertible for use with other gases, unless a certified kit is used.

## Table of Contents

### Consumer Safety Information

<i>Safety Definitions</i> .....	3
<i>Safety Behaviors and Practices</i> .....	3
<i>Safety Features</i> .....	4

### Specifications

<i>Appliance Specifications</i> .....	4, 5
<i>Features</i> .....	5

### Operating Instructions

<i>Getting to Know your New Heating Appliance</i>	6
<i>Control Panel</i> .....	7
<i>LED Display</i> .....	7
<i>Setting the Clock</i> .....	8
<i>Operating the Heater Manually</i> .....	9
<i>Programmable Weekly Timer</i> .....	10
<i>Programming the Weekly Timers</i> .....	11
<i>Programming the Weekly Timers (Example)</i> .....	12, 13
<i>Weekly Timer Review Function</i> .....	14
<i>Your Weekly Timer Program</i> .....	15
<i>Factory Pre-set Program</i> .....	15
<i>Operating the Timers</i> .....	16
<i>Override Function</i> .....	17
<i>Frost Protection</i> .....	18
<i>Energy Saving Mode</i> .....	19
<i>Function Lock</i> .....	20
<i>Humidifier and Air Flow Direction</i> .....	21
<i>Care and Maintenance</i> .....	22
<i>Before Making a Service Call</i> .....	23
<i>Fault Codes</i> .....	24
<i>Restart Function</i> .....	25
<i>Troubleshooting</i> .....	25

### Installation Instructions

<i>General Instructions</i> .....	26
<i>Gas Connection</i> .....	27
<i>Clearances to Combustibles</i> .....	27
<i>Flue Terminal Clearances</i> .....	28, 29
<i>Dimensions</i> .....	30
<i>Installation Parts</i> .....	31
<i>Drilling Flue Hole</i> .....	32
<i>Flue Manifold Installation</i> .....	33, 34
<i>Extension Kit Installation</i> .....	35-37
<i>Connecting the Appliance</i> .....	38
<i>Operating Instructions</i> .....	39
<i>Cut-Away Diagram</i> .....	40
<i>Wiring Diagram</i> .....	41
<i>Ladder Diagram</i> .....	42
<i>Flow Diagram</i> .....	43
<i>Parts List</i> .....	44-49

### Consumer Support

<i>Warranty Information</i> .....	50
<i>Limited Warranty</i> .....	50, 51

# Consumer Safety Information

## Safety Definitions



This is the safety alert symbol. This symbol alerts you to potential hazards that can kill or hurt you and others.



Indicates an imminently hazardous situation which, if not avoided, will result in death or serious injury.



Indicates a potentially hazardous situation which, if not avoided, could result in death or serious injury.



Indicates a potentially hazardous situation which, if not avoided, could result in minor or moderate injury. It may also be used to alert against unsafe practices.

## Safety Behaviors and Practices



- Keep the area around the appliance clear and free from combustible materials, gasoline, and other flammable vapors and liquids.
- Never store liquid propane containers indoors.
- Do not use this appliance if any part has been under water. Immediately call a qualified service technician to inspect the appliance and to replace any part of the control system and any gas control which has been under water.
- This appliance is equipped with a three-prong plug for your protection against shock hazard and should be plugged directly into a properly grounded three-prong receptacle. Do not cut or remove the ground prong from this plug.
- Any alteration to the appliance or its controls can be dangerous.
- Do not operate appliance with the panels removed, cracked or broken. Replacement of the panels should be done by a licensed or qualified service person.



- Do not block the warm air discharge. Do not allow anyone to sleep directly in front of the appliance.
- Due to high temperatures, the appliance should be located out of traffic and away from furniture and draperies.
- Children and adults should be alerted to the hazards of high surface temperature and should stay away to avoid burns or clothing ignition.
- Young children should be carefully supervised when they are in the same room as the appliance.
- Clothing or other flammable material should not be placed on or near the appliance.
- Any safety screen or guard removed for servicing must be replaced prior to operating the appliance.
- Do not insert items into the louvers.
- Do not spray aerosols near the appliance while it is operating. Most aerosols contain butane gas which is flammable.
- Do not unplug the appliance while it is operating or while the fans are on.

## Safety Features

- **Overheat:** The appliance will automatically shut down when the appliance exceeds a predetermined temperature.
- **Flame Failure:** The appliance will automatically shut down if the burner flame is extinguished.
- **Power Failure:** The appliance will cut off the gas if it loses electrical power.
- **Power Surge Fuse:** A glass fuse on the PC board protects against overcurrent. If the fuse blows then all indicator lamps will be off.
- **Spark Detector:** The appliance automatically shuts down if there is an abnormal spark at ignition.
- **Fusible Link:** In case the overheat feature prevents the temperature from rising then the fusible link will break shutting off the appliance.

## Specifications

### Appliance Specifications

Application	For manufactured home (USA only) or mobile home or residential installation convertible for use with natural gas and liquefied petroleum gases (propane / LPG) when provision is made for the simple conversion from one gas to the other. For commercial setting. For installation at altitudes up to 10,200 feet (3109 m).
General Description	Forced combustion, forced convection, flued gas furnace
Operation	Push button electronic
Gas Connection	1/2 in female NPT
Gas Control	Electronic
Burners	Stainless steel Bunsen burner
Temperature Control	Electronic thermostat
Ignition System	Electronic spark ignition
Flue System	The flue must be terminated to atmosphere with only flue components listed with the appliance's certification. Warranty will be voided if non listed components are installed.
Humidifier Tray	Capacity - 3 pints (1300 cc)
Electrical Connection	AC 120V, 60 Hz, 47 watts
Weight	51 lbs (23 kg)
Noise Level	32-41 dB
AFUE Rating	Natural Gas: %      Propane: %

Rinnai is continually updating and improving products. Therefore, specifications are subject to change without prior notice.

The efficiency rating of this appliance is a product thermal efficiency rating determined under continuous operating conditions and was determined independently of any installed system.

## Appliance Specifications

---

	Natural Gas	Propane Gas
Minimum supply gas pressure	3.5 in (89 mm) W.C.	8.0 in (203 mm) W.C.
Maximum supply gas pressure	10.5 in (267 mm) W.C.	13.0 in (330 mm) W.C.

EX17		
	Natural Gas	Propane Gas
BTU/hour input	Low 8200 High 16700	Low 8200 High 16700
BTU/hour output	Low 6560 High 13360	Low 6560 High 13360

EX22		
	Natural Gas	Propane Gas
BTU/hour input	Low 8200 High 21500	Low 8200 High 20700
BTU/hour output	Low 6560 High 17200	Low 6560 High 16560

## Features

---

- Restarts automatically when ignition or combustion fails.
- Clean Heating Forced Flue Type
- Easy Operation One-Touch Ignition
- Sensible Temperature Control Feature
- Comfortable Room Temperature Control and Display
- Warm Air Outlet at Floor Level (keeps your feet warm)
- Function Lock
- Room Temperature Setting Memory
- Clean the Air Filter - Indicator Lamp
- Energy Saving Economy Setting
- Humidifier Tray
- Air Flow Directional Louvers
- Direct Vent Easily Installed
- Proportional Heating Variable Capacity
- Hush! Quiet Operation
- Modern Design Minimizes Floor Space Requirements
- Fault Code Message Display

# Operating Instructions

## Getting to know your new heating appliance

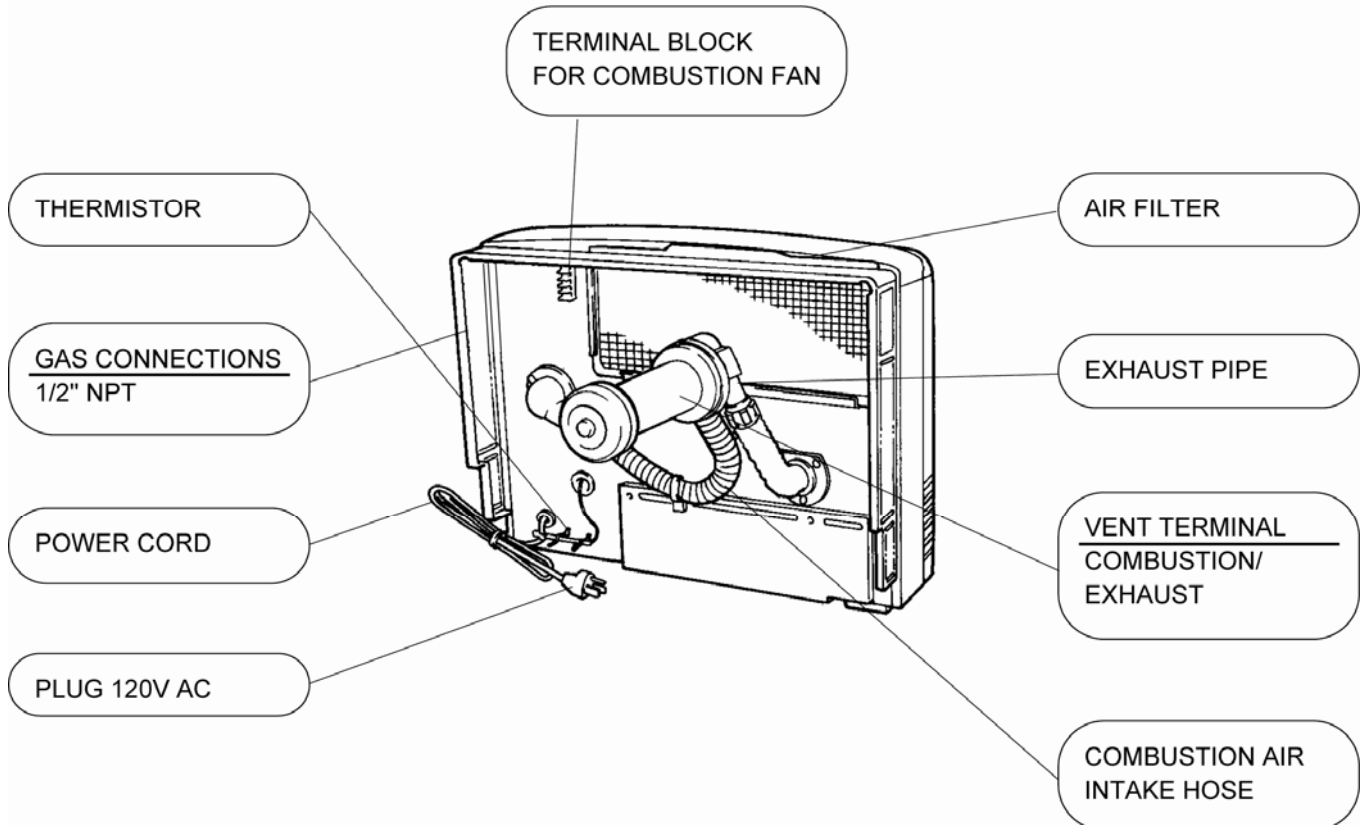
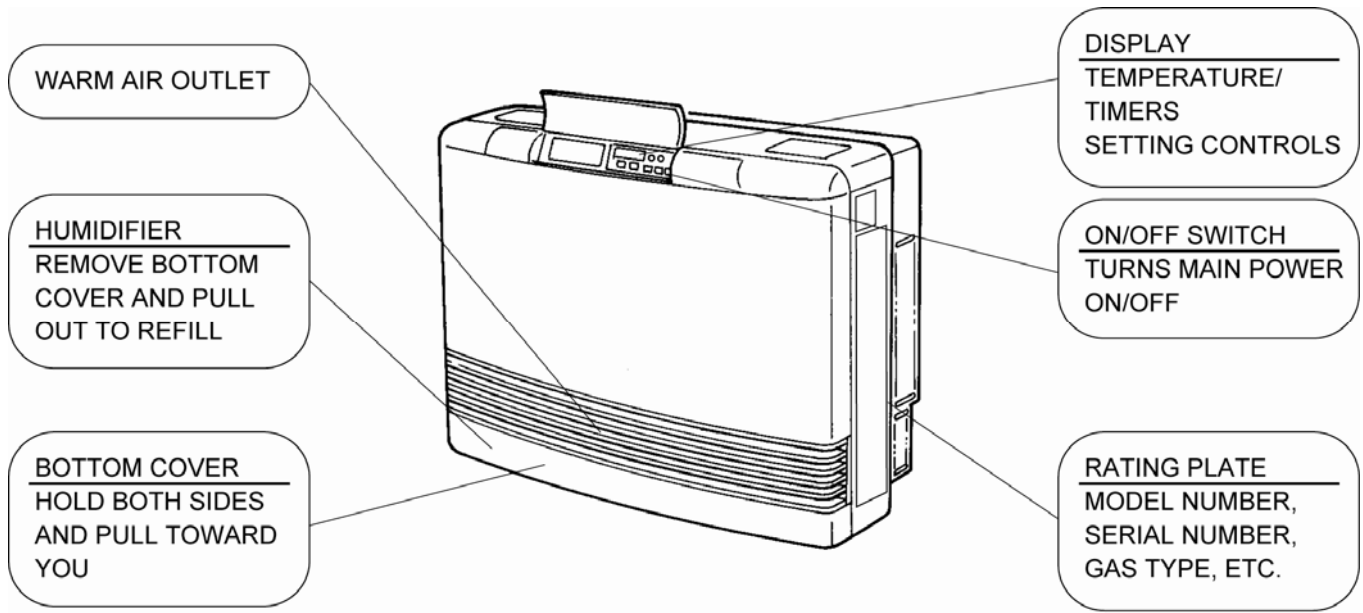

## Control Panel

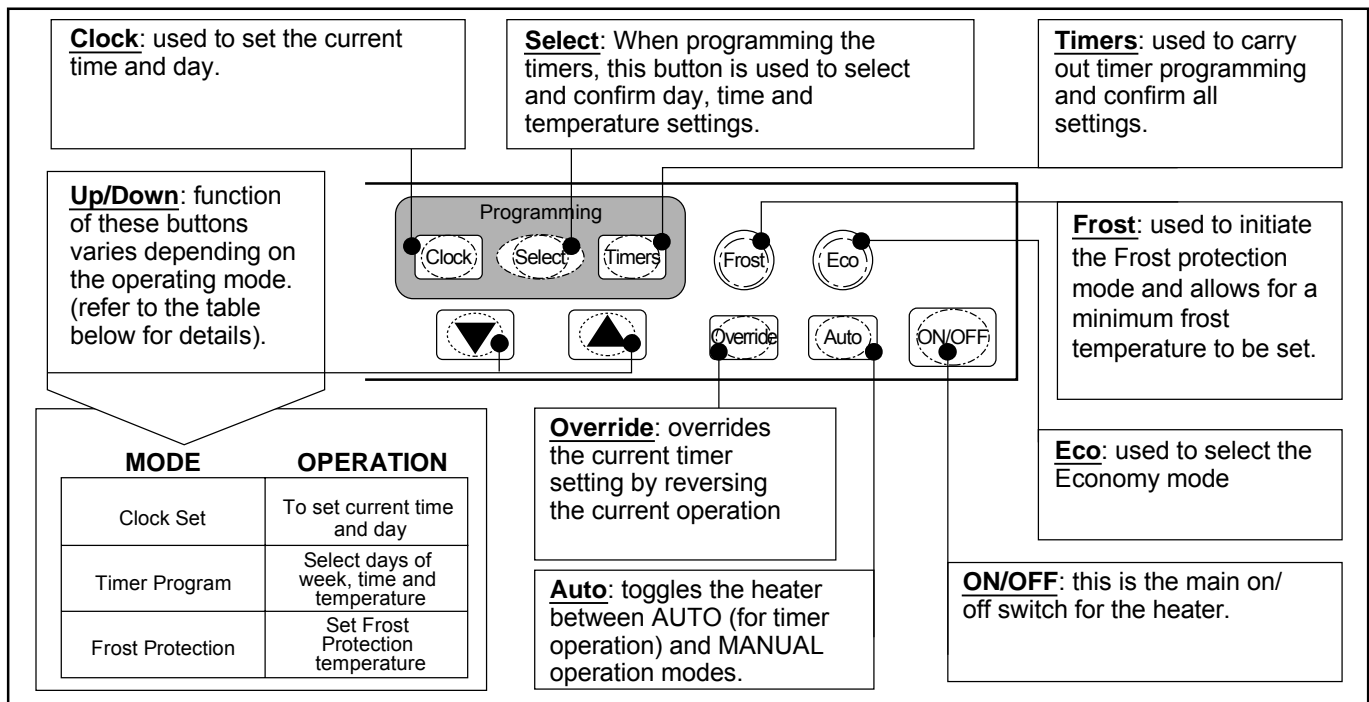

## LED Display

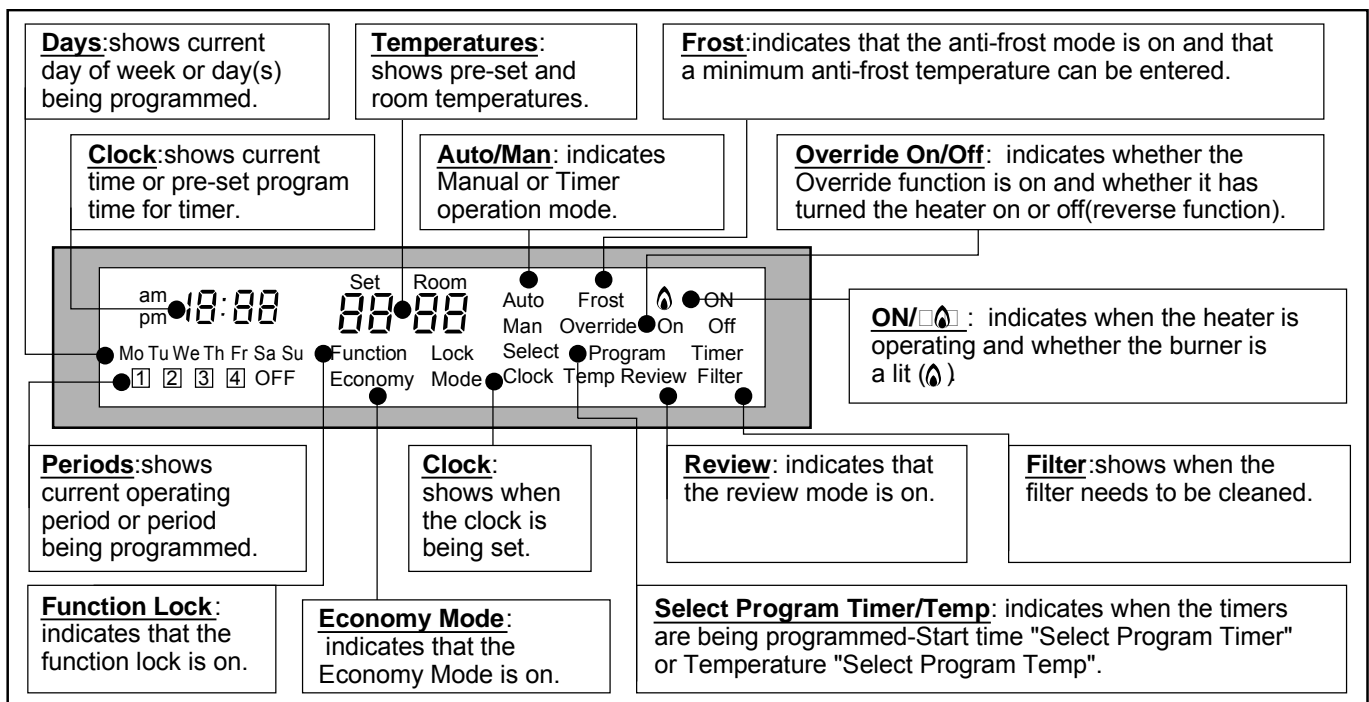

## Sensible Temperature Control

The sensible temperature control feature allows comfortable heating which matches the conditions in the room.

Based on the information collected by the room temperature thermistor when the heating starts, the heating capacity is automatically adjusted to achieve a comfortable heating effect and to reach the temperature setting quickly.

# Setting the Clock

## TO OPEN THE CONTROL PANEL

Lift lightly in the center of the lid. The control panel lid will then drop backward to an angle.

Note: When the appliance is first plugged in or after a power failure longer than 24 hours the display will show "PF".

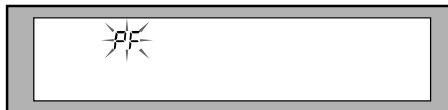

## SETTING THE CURRENT TIME & DAY

(This example shows setting the clock to 8:20am on Saturday).

### DAY OF THE WEEK

1

Press the "Clock" button once. The day of the week and Select Clock is displayed.

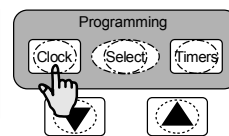
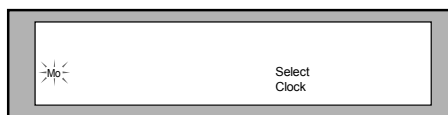

2

Press either of the "▲" or "▼" buttons until the correct day of the week is displayed.

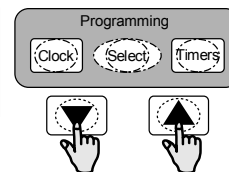
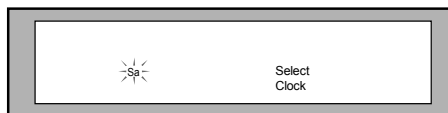

3

Press the "Select" button once to lock in and complete day of the week selection. The time of day will then flash.

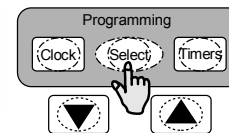
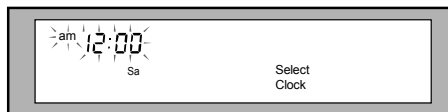

### TIME OF DAY

4

To set the time press the "▲" or "▼" buttons until the correct time of day is displayed.

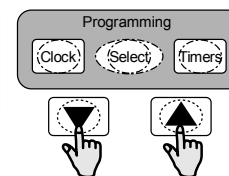
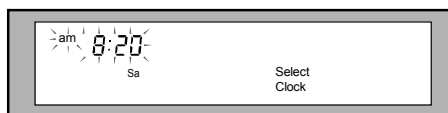

- Pressing either button once will change the time in single minutes.
- Holding either button down will change the time rapidly, first in minutes, then in hours.

### CONFIRM SETTINGS

5

Press the "Select" or "Clock" button once to lock in and complete setting the time. The Select Clock indicators will go out.

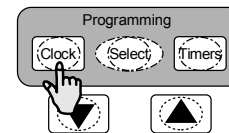
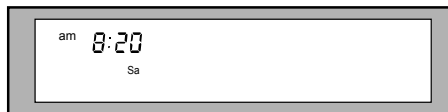

■ To turn the heater ON:

**1** Press the "ON/OFF" button.



**2** Check to see if the "Man" (Manual) or "Auto" (Automatic) indicator is displayed:

If the "Auto" indicator is displayed then press the "Auto" button. The indicator will change to "Man". Go to Step 3.

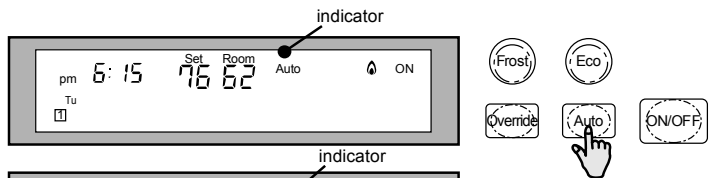

If the "Man" indicator is displayed go to Step 3.

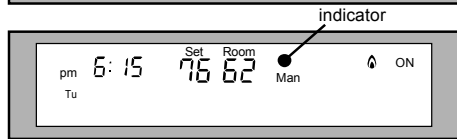

**3** Select the desired room temperature by pressing the "▲" or "▼" buttons. Temperatures are available in 2 degree increments.

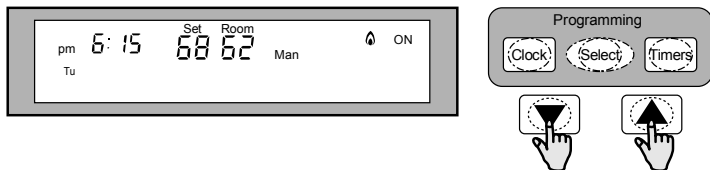

- The heater will start and run for 90 seconds so that it can check the room temperature (the flame icon will show).
- If the room temperature is lower than the pre-set or desired temperature the heater will continue to run.
- If the room temperature is higher than the pre-set or desired temperature, the heater will go into "stand-by" mode, and will start when the room temperature falls below the pre-set temperature.

If the heater does not ignite on initial use, this may be due to air remaining in the gas supply line. The spark generator will only continue for 15 seconds. After this it will be necessary to press the ON/OFF button OFF, then ON again.

■ To turn the heater OFF:

**1** Press the "ON/OFF" button.

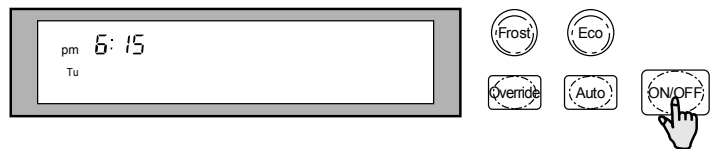

DO NOT turn heater off by unplugging the power cord. The convection fan will continue to run until the appliance cools.

## Programmable Weekly Timer

- The four timer periods create up to four separate operating intervals, each with its own temperature setting.
- These periods can be programmed differently for each day of the week, or for a group of days: weekdays, weekends, or the entire week.
- The programming covers a 24 hour time span (one day).

The two diagrams below graphically represent examples of weekday and weekend programs.

### Weekday Program

- Period 1 has been programmed to start at 5:30 am with a temperature setting of 76° F. The appliance will heat the room at 76° F until 8:00 am, when period 2 starts.
- Period 2 has a temperature setting of “nothing” or OFF, and so the heater will not operate again until the start of period 3 at 5:00 pm.
- Period 3 heats the room from 5:00 pm to 9:30 pm at 72° F.
- Period 4 turns the appliance OFF until Period 1 begins the next day.

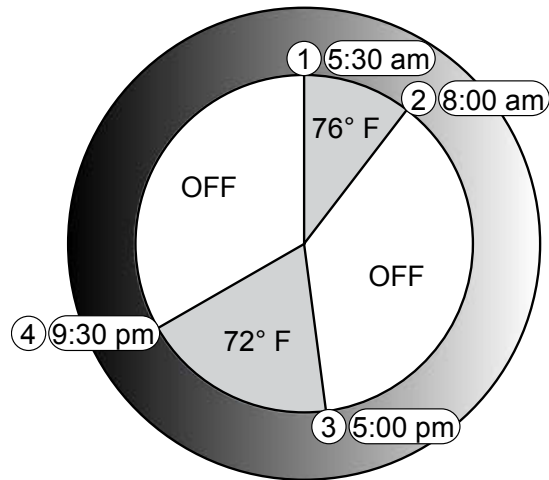

### Weekend Program

- Period 1 has been programmed to start at 9:00 am with a temperature setting of 76° F. The appliance will heat the room at 76° F until 11:00 am, when period 2 starts.
- Period 2 has a temperature setting of “nothing” or OFF, and so the heater will not operate again until the start of period 3 at 4:00 pm.
- Period 3 heats the room from 4:00 pm to 11:00 pm at 72° F.
- Period 4 has a temperature setting of LOW and runs the appliance at this setting during the night.

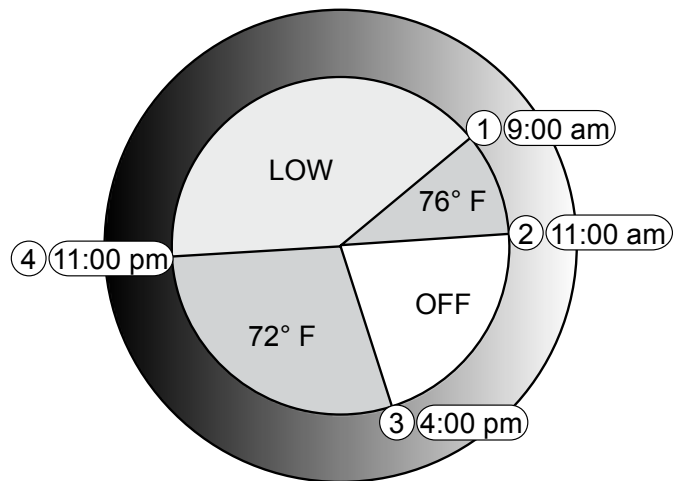

# Programming the Weekly Timers

- The following is a general outline of the setting options and procedures available when programming the weekly timers.

Note: Before programming the current time and day must be set.

- The weekly timers can be easily programmed by following the steps illustrated below:

- 1** Press the "Timers" button once to activate the timer programming mode.

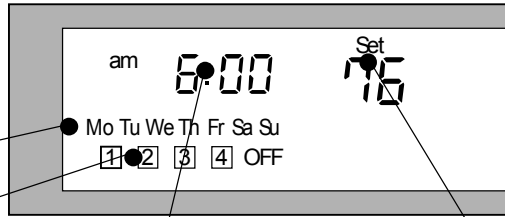

- 2** Select the day or group of days you wish to program by pressing the "up" and "down" buttons:

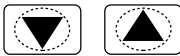

Choose from the following options:

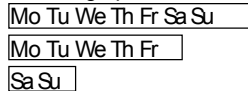

or each day of the week in turn.

If a group of days is chosen, the times and temperatures selected in steps 3 → 5 will automatically apply for those days.

Press the "Select" button to confirm your choice.



- 3** Select the period you wish to program by pressing the "up" and "down" buttons:



Periods 1 → 4 will automatically appear in order as you follow this programming sequence, so you may not need to manually select a timer period.

Press the "Select" button to confirm your choice.



- 4** Set the start time for this period by pressing the "up" and "down" buttons:



The time will move up or down in 10 minute increments.

Each period must be set to a later time than the period before it.

No period can be set past 11:50pm, as this is the end of the 24hour program.

Press the "Select" button to confirm the time.



- 5** Set the temperature you want for this period by pressing the "up" and "down" buttons:



Choose from the following temperature settings:

H(high, maximum fire)  
80° F –60° F  
L(low, minimum fire)  
-- (OFF)

If you want heat during this period, choose a temperature.

If you do not want heat, choose the OFF setting.

Press the "Select" button to confirm the temperature setting.



- 6** Repeat steps **3** → **5** for periods 1 through to 4 until you are happy with all the settings.

- 7** Press the "Timers" button again to confirm your program and lock in all settings.

## Programming the Weekly Timers (Example)

Note: Before programing the timers, the clock must be set to the correct time.

- The following is a step by step guide to programing the timers by an example schedule.
- If programing is paused for longer than 2 minutes the display will return to the current time, and all programing up to that stage will be lost.
- The times and temperatures in the EXAMPLE box below can be used for learning how to set the programmable thermostat.

- **EXAMPLE** Let's use the following schedule to program the weekdays ...

### EXAMPLE SCHEDULE

	Time Setting	Temperature
1	5:30 am	76°F
2	8:00 am	OFF
3	5:00 pm	72°F
4	9:30 pm	OFF

- 1** Press the “Timers” button once. The display will show “Select Program Timer” and the “Mo Tu We Th Fr Sa Su” indicators will flash.

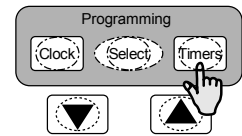

- 2** Press the “▲” button once, the “Mo Tu We Th Fr” indicators will flash.

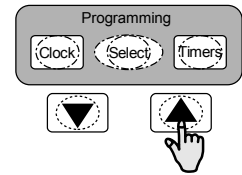
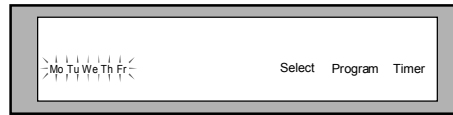

- 3** Press the “Select” button once, the period 1 indicator will flash and the time and temperature display will be shown.

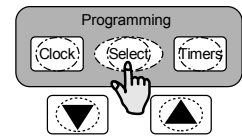
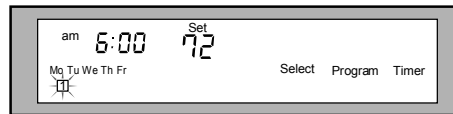

- 4** Press the “Select” button again. The period 1 indicator will become stable, the temperature display will go out and the clock will flash.

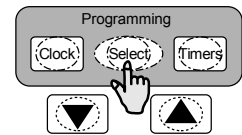
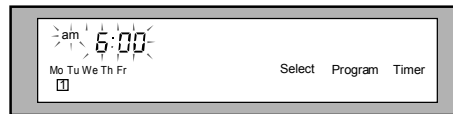



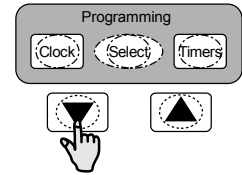
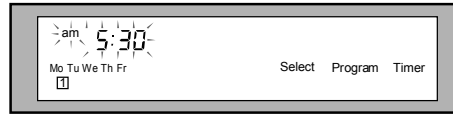

- 5** Press the “▼” button until the display shows “am 5:30” (as shown in the example schedule for period 1).

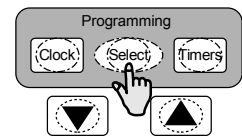
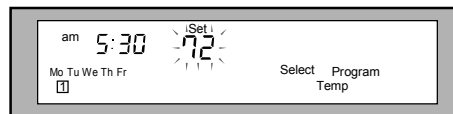

- 6** Press the “Select” button again. The clock indicator will become stable, the pre-set temperature will flash and “Select Program Temp” will be shown.

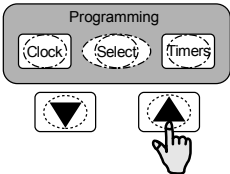
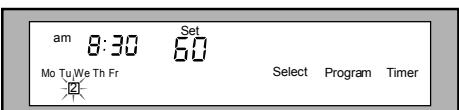
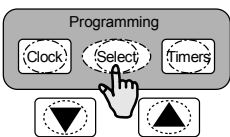

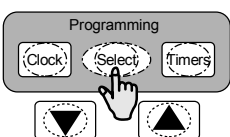
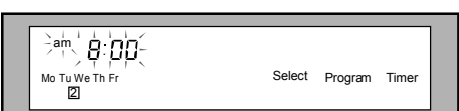
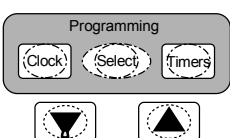
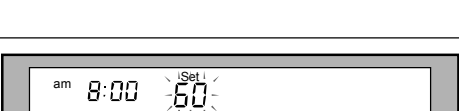
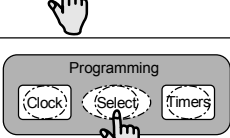
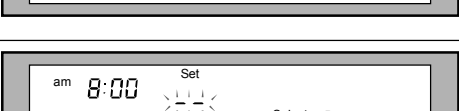
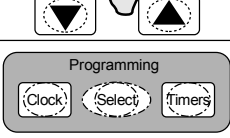
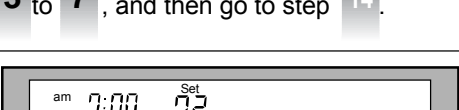
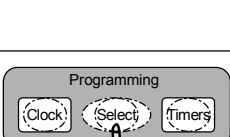
## Programming the Weekly Timers (Example)

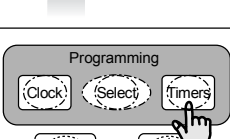
7	Press the “▲” button to set the pre-set temperature to 76°F (remember, we are using the example schedule).		
8	Press the “Select” button again. Now the period 2 indicator will flash and the time and temperature display will be shown.		
9	Press the “Select” button again. The period 2 indicator will become stable, the temperature display will go out and the clock indicator will flash.		
10	Press the “▼” button until the display shows “am8:00”(as in the example for period 2 ).		
11	Press the “Select” button again. The clock indicator will become stable, the pre-set temperature will flash and “Select Program Temp” will be shown.		
12	Press the “▼” button until the temperature shows “- -” and the “OFF” indicator is displayed.		
13	Set periods 3 and 4 following/repeating steps <b>3</b> to <b>7</b> , and then go to step <b>14</b> .		
14	Press the “Select” button again. The period 1 indicator will flash and “Sa Su” will be displayed.		
15	You can now program a Weekend schedule by repeating steps <b>3</b> to <b>7</b> , and then go to step <b>16</b> .		
16	Once all timers are programmed, Press the “Timers” button once to save all timer settings. The display will return to the current time and the “Set Program Timer” indicator will go out.		

- To review all of the programmed settings go to - “ **WEEKLY TIMER REVIEW FUNCTION** ”
- For a description of how to operate the heater with these programmed settings, go to “ **OPERATING THE TIMERS** ”.

## Weekly Timer Review Function

- This function lets you review all of the programmed Weekly Timer settings (times and temperatures) without the option of adjusting these settings, removing the danger of accidentally changing the program.
- This is a quick way to review the Weekly Timer program before operating the timers.

### ■ To enter the Weekly Timer Review mode:

NOTE: If the heater is left in "Timer Review Mode" for longer than 10 seconds without the "▲" or "▼" buttons being pressed, it will exit this mode and return the previous operation.

1

- Press and hold the "Timers" button for approximately 3 seconds (an audible "beep" will be heard).

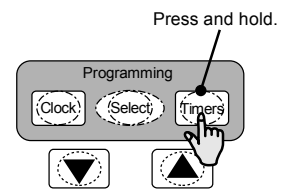
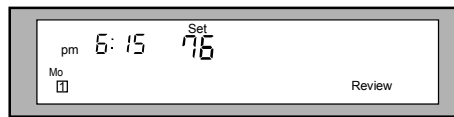

NOTE:

- The Period 1, "Mo", time, temperature, and "Review" indicators will show.

2

- Press the "▲" button repeatedly to review the Weekly Timer program.
- The four timer periods for each day of the week will show in turn, starting with "Mo" (Monday) then "Tu" etc.
- Press the "▼" button to go backwards through the program.

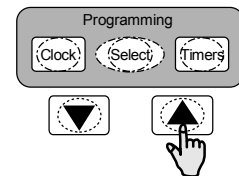
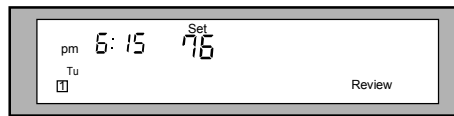

### ■ To exit the Weekly Timer Review mode:

1

- Press the "Timers" button..

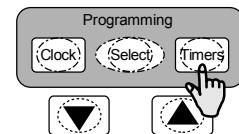
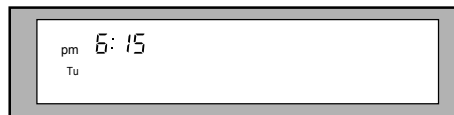

## Your Weekly Timer Program

### ■ Points to consider before writing your program:

- When do I want the heater to operate, and what temperature do I want?
- When do I not want the heater to operate?
- Will I use the same settings for everyday day of the week, or do I need a separate program for the weekdays, and the weekend? Do I need a separate setting for each day of the week?

### ■ Points to remember when writing your program:

- The four periods are set within a 24 hour time span.
- The start of a new period marks the end of the previous one, so each period only requires a START time.
- Period 4 ends with the start of period 1 on the next day.
- Each period must be set to a later time than the one before it.
- If you want to heat during the period, select a temperature: H(high), 80° F → 60° F , L(low).
- If you do not want to heat during this period, select the OFF setting.

### ■ Write your own program:

- Use the tables below to write your own weekly timer program, then program the timers.

	Start Time	Temperature or OFF
1		
2		
3		
4		

	Start Time	Temperature or OFF
1		
2		
3		
4		

## Factory Pre-set Program

- The heater comes shipped with a factory set program(opposite).
- If the heater is not set with a new program it will run according to this program when you operate the timers.
- If the Weekly Timer program settings are erased, the heater will revert to this program.

### WEEK DAY

	Start Time	Temp or OFF
1	6:00 am	72°F
2	8:30 am	60°F
3	5:00 pm	74°F
4	11:30 pm	60°F

### WEEK END

	Start Time	Temp or OFF
1	7:00 am	72°F
2	12:00 pm	70°F
3	5:00 pm	74°F
4	11:30 pm	60°F

## Operating the Timers

- Before operating the timers, please check the following points:
  - The clock must be set to the current time and day.
  - If no personal program is entered, the heater will operate according to the the default factory settings

- Follow the steps below to operate the timers:

**1** Press the “ON/OFF” button. The “Man”(Manual) and “ON” indicators will come on as well as the preset and room temperatures.

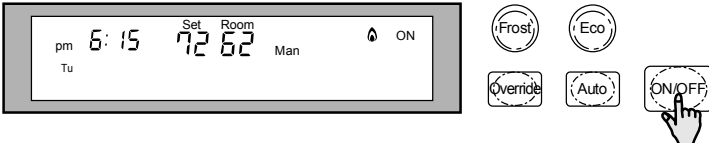

- 2** Press the “Auto” button. The “Man”(Manual) indicator will be replaced by the “Auto”(Automatic) indicator, and the current timer period will show.

If the current period has been programmed with a temperature, the heater will start heating.

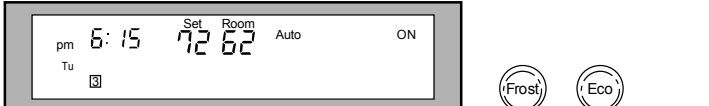

If the current period has been programmed with an OFF setting the heater will not heat during this period.



- 3** The heater will now operate according to the four periods programmed into the Weekly Timer.

## Returning to Manual Mode

**1** Press the “Auto” button. The “Auto” indicator will go out and be replaced by the “Man”(Manual) indicator. The heater will now heat depending on your manual settings.

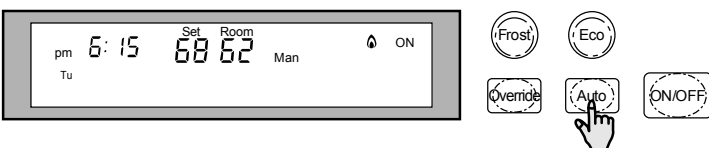

## Override Function

- This function is used when the heater is in “Auto” mode(timer operation).
- It allows you to “Override” the preset timer setting until the beginning of the next period.
- For example, if the heater is ON, pressing the “Override” button will turn it OFF until the next period. If the heater is OFF, pressing the “Override” button will turn the heater ON, and allow you to select a temperature, until the next period.

### ■ To turn on the Override function:

- Remember: The Override function is for use in the “Auto”(timer) mode only.

1

- Press the “Override” button.



- One of the following will happen depending on the current timer period setting:

#### If the current timer period is ON (heating)

The heater will turn OFF, the temperatures will display “-”, and the “Override” and “Off” indicators will light.

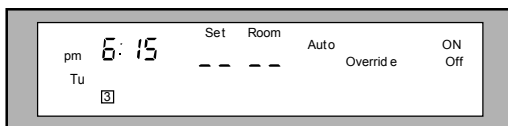

2

- The heater will remain OFF until
  - a. the next timer period, or
  - b. the Override function is turned off manually(see step below).

or

#### If the current timer period is OFF

The heater will turn ON, the manual pre-set temperature and room temperature will show, and the “Override” and “On” indicators will light.

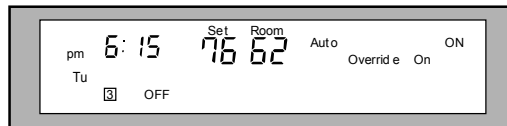

- Press the “▲” or “▼” buttons to manually adjust the pre-set room temperature.

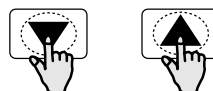

- The heater will remain heating until
  - a. the next timer period, or
  - b. the Override function is turned off manually (see step below)..

### ■ To turn off the Override function:

1

- Press the “Override” button.
- Then the heater will return to the operation of the current timer period.

## Frost Protection

- This function allows a minimum room temperature to be pre-set, between 38 °F and 60°F (in 2° F increments). Once the Frost Protection function is selected the appliance will start heating whenever the room temperature falls below the selected temperature, regardless of timer or manual settings.

- Follow the steps below to set and operate the Frost Protection:

**1** Make sure the heater is turned OFF.

**2** Press the “Frost” button. The Frost Protection temperature and the “Frost” indicator will be displayed.



**3** Press the “▲” and “▼” buttons to select the Frost Protection temperature. (Between 38°F and 60°F).

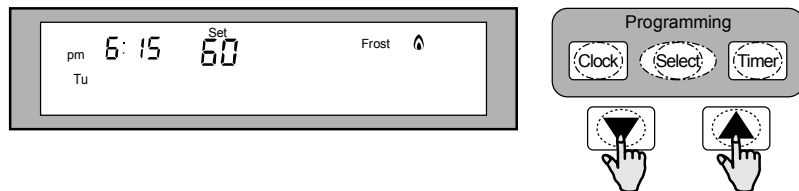

- When the “Frost” indicator is displayed the Frost Protection is operating, and will always prevent the room temperature from falling below the pre-set Frost Protection temperature.

- To turn off the Frost Protection:

**1** Press the “Frost” button. The “Frost” indicator will go out.

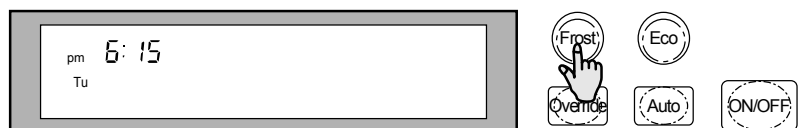

# Energy Saving Mode

- The Economy mode can only be set while the heater is operating (heating), but once set it will remain in the system memory until deactivated.

## ■ To turn on the Economy mode:

Note: The Economy Mode may only be set while the heater is operating(heating).

- 1 Press the “Eco” button. The “Economy Mode” indicator will light.

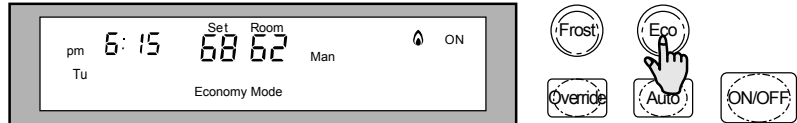

- The Economy Mode now remains in the system memory.
- If the appliance is turned off manually, or stops heating as a result of an OFF timer period, the “Economy Mode” indicator will go out.
- Whenever the appliance starts heating again, the “Economy Mode” indicator will light.

## ■ To turn off the Economy Mode:

Note: The Economy Mode can only be turned off while the heater is operating(heating), i.e when the “Economy Mode” indicator is showing.

- 1 Press the “Eco” button. The “Economy Mode” indicator will go out.

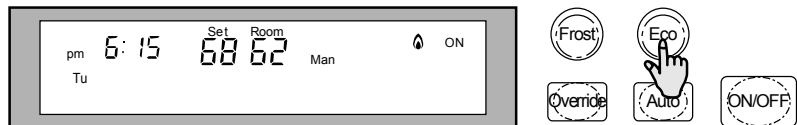

## ■ Economy Mode: Information

After the room is heated initially the air temperature may be dropped to a lower level without affecting comfort. 30 minutes after the selected room temperature (set manually with the “▲” and “▼” buttons or in an On timer period) is reached, the Economy Mode, if set, reduces the temperature by 2°F. After another 30 minutes it reduces the temperature by a further 2°F, effectively saving energy.

The Economy Mode will not operate if the heater is under capacity for the room size.

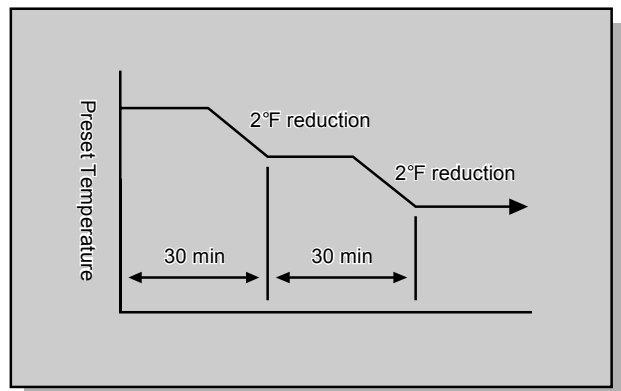

## Function Lock

- The Function Lock will help to prevent accidental operation of the appliance as well as children from altering the controls.

### ■ To activate the Function Lock:

- 1 Press the “▲” and “▼” buttons at the same time. The “Function Lock” indicator will light.

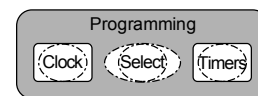
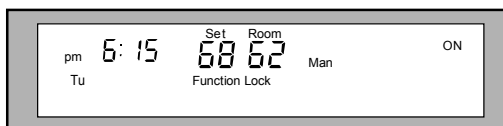

At the same time

### ■ To deactivate the Function Lock:

- 1 Press the “▲” and “▼” buttons at the same time for approx 2 seconds until a “beep” is heard. The “Function Lock” indicator will go out.

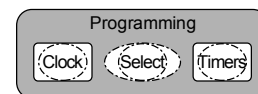
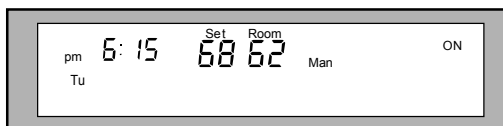

At the same time for 2 seconds

### NOTE:

- The lock can be activated when the heater is ON or OFF.
- If activated while the heater is ON, all controls other than the OFF switch will be locked.
- If activated while the heater is OFF, then all controls will be locked.
- If the heater is turned off while the Function Lock is activated, it cannot be turned on again until the lock is deactivated.
- Deactivating the lock releases the controls.

## Humidifier and Air Flow Direction

### Adding Water to the Humidifier

**CAUTION** Do not remove the bottom trim panel or the humidifier tray while warm air is flowing.

Warm air is humidified when it passes over the water in the tray.

To fill the tray, remove the bottom trim panel below the louvers by pulling on both sides. Pull the tray out and fill with water. Push the tray back in and attach the bottom trim panel. Do not operate the appliance unless the humidifier tray is installed.

During operation a small amount of condensation is produced in the flue system and drains into the humidifier tray.

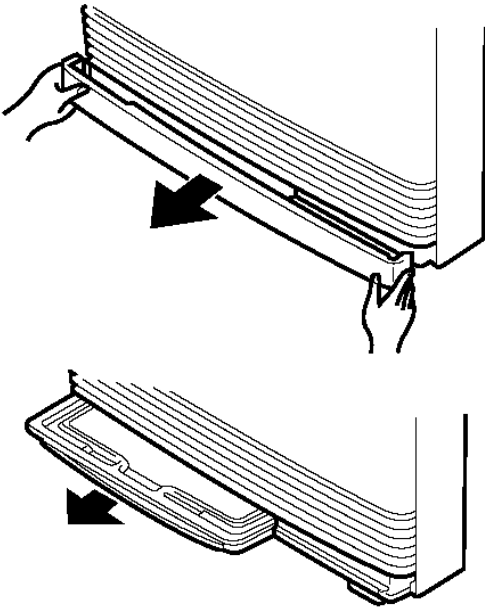

### Adjusting Air Flow Direction

**CAUTION** Do not adjust the air flow louvers while warm air is flowing.

The vertical louvers may be adjusted to move the air flow more to the right or to the left.

Use a screw driver or similar object to bend each louver to the desired position.

Do not bend repeatedly (no more than 5 times) or else the louver will break.

The horizontal louver (which determines the vertical air flow direction) is fixed and cannot be adjusted.

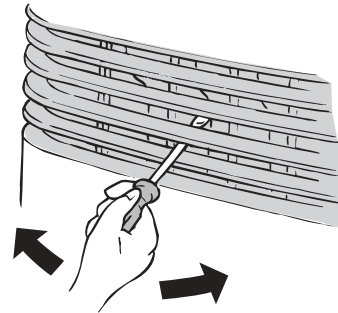

## Care and Maintenance

### Maintenance

All maintenance and service are to be performed by a qualified service technician, preferably one who has attended Rinnai service training classes on the Direct Vent products.

The appliance should be inspected annually by a qualified service technician. More frequent cleaning may be required due to excessive lint from carpeting, bedding material, etc. It is imperative that control compartments, burners, and circulating air passage ways of the appliance be kept clean.

Any screen or guard removed for servicing the appliance must be replaced prior to operating the appliance. Clean as follows:

1. Turn heat off. Allow to cool for one hour.
2. Remove the front panel by removing eight screws.
3. Use pressurized air to remove dust from the main burner, heat exchanger, and fan blades.
4. Use soft dry cloth to wipe cabinet.

Do not use wet cloth or spray cleaners on the burner.

The flue should be inspected annually for blockages or damage.

Motors are permanently lubricated and do not need periodic lubrication. Keep fan and motor free of dust and dirt by cleaning annually.

Verify proper operation after servicing.

### Care of Exterior

Dampen soft cloth with warm water. Wring water out well and wipe the unit.

Do not use volatile substances such as benzene or thinners. They cause fading of the paint and deformation of the resin.

### Snow Accumulation

Keep the area around flue terminal free of snow and ice. The appliance will not function properly if the intake air or exhaust is impeded by obstructions.

Refer to the Flue Terminal Clearances. The clearance in Ref. A should be maintained from any snow accumulation.

### Filters

Dirty filters reduce the air flow and the appliance's ability to produce heat. The filters should be cleaned frequently during the heating season. If the filters become blocked the filter indicator lamp will flash red. Eventually the appliance will turn off and display fault code 14 on the control panel display.

To clean the filters, the appliance should be OFF and cool. Remove the filter and clean it using a soft dry cloth or vacuum. If the filter is greasy wash with warm soapy water, rinse, and dry completely.

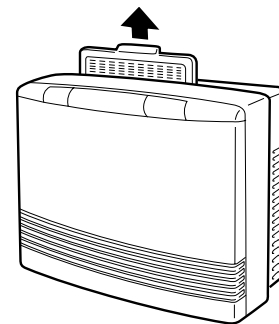

### Visual Inspection of Flame

Check that the burner flames are operating normally. The flame can be seen through the circular window through the louvers.

When operating normally the burner flame should appear as long, clear, blue, stable, streaks. Yellow flames or an orange color is abnormal and maintenance is required.

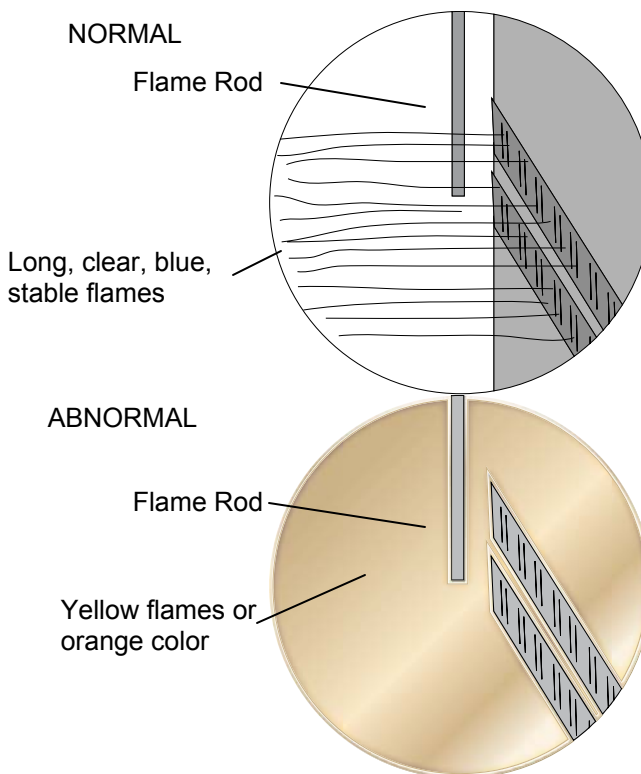

## Before Making a Service Call

---

Before making a service call please check the following:

### ■ At Ignition:

Heater does not operate.	➔	Is the heater plugged in? Have the fuses or breaker blown at the fuse box / breaker panel? Is there a power failure? Is the air filter blocked? Is anything blocking the outlet for the hot air? Is the flue blocked?
Warm air does not flow when the burner lights.	➔	The fan is started automatically after a short delay. This is to allow the heat exchanger to warm up, helping to avoid cold draughts.
Smoke or strange smells are produced on the first trial light up after installation.	➔	This is caused by grease or oil and dust on the heat exchanger and will stop after a short time.
Sharp clicking noises at ignition, or when unit cuts down on the thermostat, or goes out.	➔	This is simply expansion noise from the heat exchanger.

### ■ During Combustion:

Clunking noise when the thermostat operates.	➔	This is the sound of the solenoid gas valves opening and closing.
Unit is not heating room.	➔	Is the air filter blocked? Is the set temperature high enough? Is the warm air outlet blocked by anything? Are the doors and windows of the room closed? Was the appliance correctly sized for the space?
Air filter is blocked or the louvers are blocked or obstructed.	➔	Allow heater to cool, clean air filter, operate again.
Heater will not re-ignite after overheating.	➔	Even after unit has cooled down, the heater does not ignite again. Repair is necessary. Contact a qualified / authorized service provider.

### ■ When the unit is turned off.

Convection fan continues to run after turning OFF.	➔	This is to remove the residual heat from the heat exchanger. The fan will stop when the heater cools down.
--	---	--

### ■ Other Points:

Steam is discharged from the flue terminal .	➔	High efficiency appliances tend to discharge water vapor on cold days. This is normal.
Unit cuts off without apparent reason.	➔	Check whether filters are blocked. Dirty filters will cause the heater to overheat.
Power Failure.	➔	Switch OFF, then ON again when power is restored to re-set controls.

## Fault Codes

If there is a malfunction the appliance may shut down as a safety precaution and display a fault code to assist in diagnosing the problem. The fault code will flash in the display on the control panel. When making a service call, this code will assist with diagnosing the fault.

You may be able to clear the fault code by turning the heater off and then on again. If the fault code remains or returns on the next operation, contact Rinnai or your nearest service agent and arrange for a service call.

CODE DISPLAYED	FAULT	REMEDY
11	Ignition Failure	Check that gas is turned ON. Check that the vent termination is not blocked. Refer to the Restart Function explanation. Service call if repeated.
14	Overheat	Clean filter. Service call if repeated. [1]
16	Room Overheat	Lower room temperature to less than 104°F (40°C).
31	Room Temperature Sensor Faulty	Service call.
32		
33	Overheat Temperature Sensor Faulty	Service call.
34		
49	Sensor Breakdown	Service call.
53	Sparker Failure	Service call.
61	Combustion Fan Failure	Service call.
70	Faulty ON/OFF Switch	Service call.
71	Faulty Solenoids	Service call.
72	Faulty Flame Rod	Service call.
73	Communication Error	Turn heater OFF, then ON again.
99	Flue Block	Check around the flue terminal for blockage. [2]

[1] Remove any obstructions. The flue needs to be kept clear to expel exhaust gases. If the appliance fails to operate contact a qualified service agency.

[2] If the fusible link needs replacement, it must be done by a qualified service agency. In addition, the cause of the overheat needs to be determined. The fusible link is a one use safety device that breaks to shut off the appliance.

## Restart Function

If the appliance fails to ignite, the appliance will attempt ignition after 1 hour. The “Ignition Failure” fault code, 11, will appear during that hour and disappears after a successful ignition. If ignition fails again, then the fault code will remain and another attempt to ignite will occur in 1 hour. The fault code is not stored in the fault code history.

If the flame is extinguished during forced combustion then the appliance will attempt ignition after 1 hour. The “Ignition Failure” fault code, 11, will appear during that hour and disappears after a successful ignition. Forced combustion takes place for about 15 seconds after ignition. After this time, the temperature control logic controls the combustion.

If the flame is extinguished (burner combustion failure) while the temperature control logic is operating the appliance, then the appliance will immediately attempt ignition. No fault code will appear.

## Troubleshooting

Cause \ Problem	No ON indicator	Burner doesn't ignite	Unusual combustion	Combustion stops during operation	Smell of gas	Noisy ignition	Takes too long to warm the room	Remedy
Not Plugged In	●	●						Plug In
Power Failure	●	●		●				Push On/Off button to attempt restart after power is restored.
(Initial Installation) Air In Gas Pipe		●						Purge air (Installer)
Gas Filter Blocked		●	●				●	Service Call
Miss Ignition	●	●						Service Call
Flue terminal obstructed			●	●		●		Clear obstruction
Flue manifold not connected					●	●		Service Call
Louver obstructed				●			●	Clear obstruction
Air filter blocked				●			●	Clean filter
Gas Escape					●			Service Call
Function Lock Set		●						Cancel Function Lock
Gas turned off at meter, tank, or valve.	●	●						Turn gas on

# Installation Instructions

## General Instructions

### **WARNING**

Do not use substitute materials.

Use only parts certified with the appliance.

- A qualified service technician should install the appliance and inspect it before use.
  - If you move, check the gas type in your new area. The local gas authority will be able to advise on local regulations.
  - The installation must conform with local codes or, in the absence of local codes, with the *National Fuel Gas Code, ANSI Z223.1/NFPA 54*, or the *Natural Gas and Propane Installation Code, CSA B149.1*.
  - A manufactured home (USA only) or mobile home OEM installation must conform with the *Manufactured Home Construction and Safety Standard, Title 24 CFR, Part 3280*, or, when such a standard is not applicable, the standard for *Manufactured Home Installations, ANSI/NCSCS A225.1*, or the standard for *Gas Equipped Recreational Vehicles and Mobile Housing, CSA Z240.4*.
  - The appliance, when installed, must be electrically grounded in accordance with local codes or, in the absence of local codes, with the *National Electrical Code, ANSI/NFPA 70*, or the *Canadian Electrical Code, CSA C22.1*.
  - Appliance input ratings are based on sea level operation and need not be changed for operation up to 2000 ft (609.9 m) elevation. For operation at elevations above 2000 ft (609.9 m), refer to the Conversion Manual.
  - The appliance and its appliance main gas valve must be disconnected from the gas supply piping system during any pressure testing of that system at test pressures in excess of 1/2 psi (3.5 kPa).
  - The appliance must be isolated from the gas supply piping system by closing its equipment shutoff valve during any pressure testing of the gas supply piping system at test pressures equal to or less than 1/2 psi (3.5 kPa).
- If the flooring is carpet, tile, or other combustible material other than wood, then the appliance must be installed on a metal or wood panel extending the full width and depth of the appliance.
  - This appliance discharges a large volume of warm air next to the floor. Any particles in the air such as cigarette smoke could cause discoloration in nylon carpets containing dyes or vinyl surfaces.
  - This appliance is not designed to be built in.
  - This appliance is only for use with the type of gas indicated on the rating plate. This appliance is not convertible for use with other gases unless a certified kit is used. If conversion of the unit is needed, conversions must be performed by a qualified service provider at the owner's expense.
  - This appliance must not be connected to a chimney flue serving a separate solid-fuel burning appliance.
  - Rinnai suggests that a dedicated electrical circuit with a 120VAC, 60 hz, 10 amp power source be used.
  - Two 1/8 in test plugs are provided for testing of manifold differential pressure. They are located on the modulating gas valve and on the burner manifold.
  - The appliance should be correctly sized for the space it is required to heat.
  - Follow the installations instructions and those in *Care and Maintenance* for adequate combustion and ventilation air.
  - The flow of combustion and ventilation air shall not be obstructed.
  - Clearances to access the appliance during servicing are 2 inches (50 mm) from the sides, 40 inches (1 m) from the front, and 9 inches (225 mm) from the top.

### **NOTICE**

If installation is at a location above 2001 ft (610 m), then follow the Adjust Gas Pressure Settings procedure in the Conversion Manual.

If installation is at or below 2000 ft (610 m) then the pressure settings do not need to be adjusted.

## Gas Connection

- The gas supply line shall be gas tight, sized and so installed as to provide a supply of a gas sufficient to meet the maximum demand of the heater without loss of pressure.
- A shut off valve and appliance connector valve should be installed in the upstream of the gas line to permit servicing.
- Flexible pipe and any appliance connector valve used for gas piping shall be types approved by nationally recognized agencies.
- Any compound used on the threaded joint of the gas piping shall be a type which resists the action of liquefied petroleum gas (propane / LPG).
- After completion of gas pipe connections all joints including the heater must be checked for gas tightness by means of leak detector solution, soap and water, or an equivalent nonflammable solution, as applicable. (Since some leak test solutions, including soap and water, may cause corrosion or stress cracking, the piping shall be rinsed with water after testing, unless it has been determined that the leak test solution is non-corrosive.)
- Check the gas supply pressure immediately upstream at a location provided by the gas company. Supplied gas pressure must be within the limits shown in the Specifications section.
- Refer to an approved pipe sizing chart if in doubt about the size of the gas line.
- Install manual gas cut-off valve so that it can be accessed for easy operation. Do not conceal manual cut-off valve behind back spacer.

## Clearances to Combustibles

When determining where to install the appliance the clearances to combustibles shown in the figure must be followed. Also refer to the Safety Behaviors and Practices section. The clearance to combustibles from the top is zero.

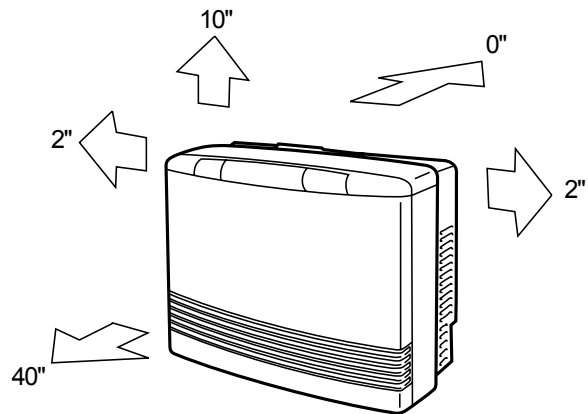

## Attach Back Covers (Sides Only)

Attach back covers as shown.

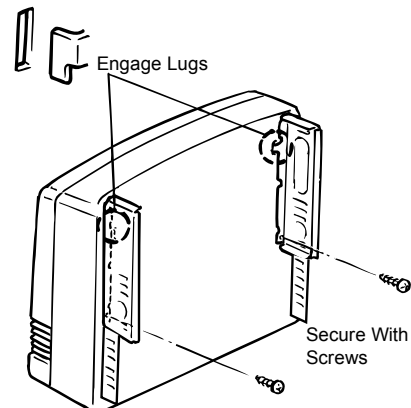

# Flue Terminal Clearances

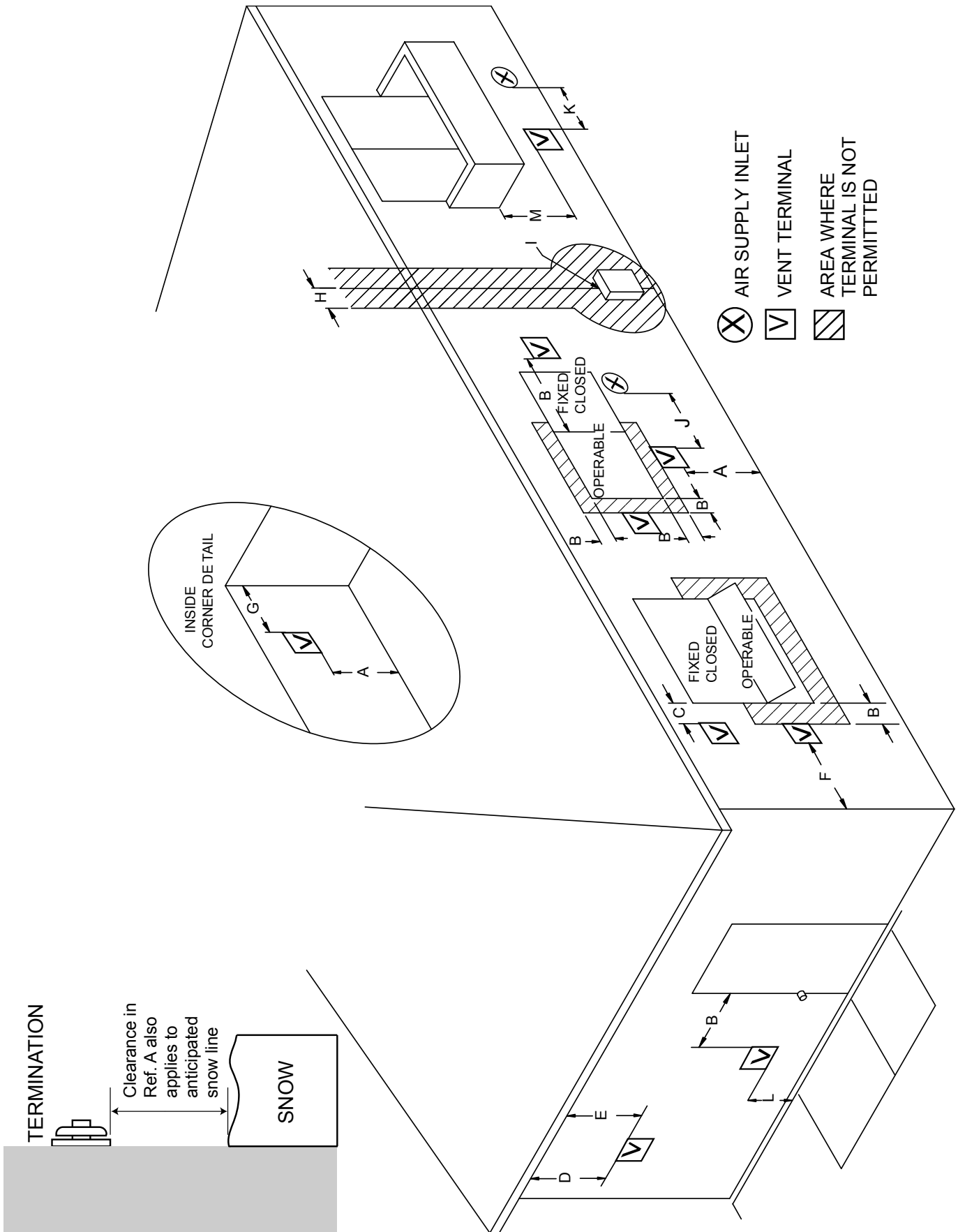

# Flue Terminal Clearances

Ref	Description	Canadian Installations	US Installations
A	Clearance above grade, veranda, porch, deck, or balcony. (Take into account the anticipated snow line)	6 inches (15 cm) for appliances ≤ 10,000 BTUh; 9 inches (23 cm) for appliances > 10,000 BTUh and ≤ 50,000 BTUh, 12 inches (30 cm) for appliances > 50,000 BTUh	6 inches (15 cm) for appliances ≤ 10,000 BTUh; 9 inches (23 cm) for appliances > 10,000 BTUh and ≤ 50,000 BTUh, 12 inches (30 cm) for appliances > 50,000 BTUh
B	Clearance to window or door that may be opened	12 inches (30 cm)	9 inches (23 cm)
C	Clearance to permanently closed window	*	*
D	Vertical clearance to ventilated soffit, located above the terminal within a horizontal distance of 2 feet (61 cm) from the center line of the terminal	*	*
E	Clearance to unventilated soffit	*	*
F	Clearance to outside corner	*	*
G	Clearance to inside corner	20 inches (50 cm)	20 inches (50 cm)
H	Clearance to each side of center line extended above meter/regulator assembly	3 feet (91 cm) within a height 15 feet (4.5 m) above the meter/regulator assembly	*
I	Clearance to service regulator vent outlet	3 feet (91 cm)	*
J	Clearance to nonmechanical air supply inlet to building or the combustion air inlet to any other appliance	12 inches (30 cm)	9 inches (23 cm)
K	Clearance to a mechanical air supply inlet	6 feet (1.83 m)	3 feet (91 cm) above if within 10 feet (3 m) horizontally
L	Clearance above paved sidewalk or paved driveway located on public property	7 feet (2.13 m) ①	*
M	Clearance under veranda, porch, deck, or balcony	12 inches (30 cm) to non-flammables ② 24 inches (60 cm) to flammables ②	12 inches (30 cm) to non-flammables ② 24 inches (60 cm) to flammables ②

- ① A vent shall not terminate directly above a sidewalk or paved driveway that is located between two single family dwellings and serves both dwellings. Permitted only if veranda, porch, deck, or balcony is fully open on a minimum of two sides beneath the floor.
- ② For clearances not specified in ANS/ Z223.1/NFPA 54 or CSA B149.1, clearances are in accordance with local installation codes and the requirements of the gas supplier.

# Dimensions

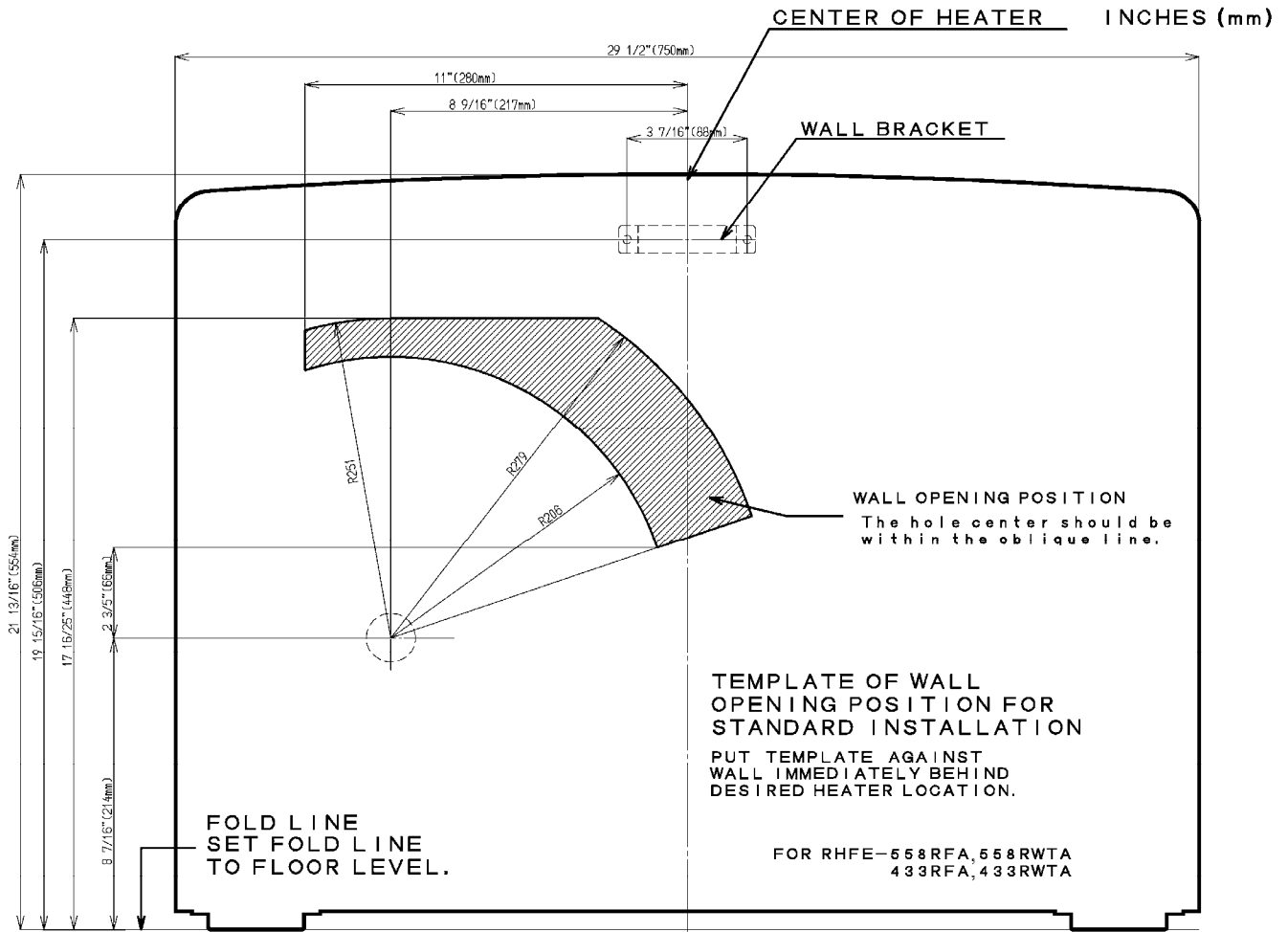





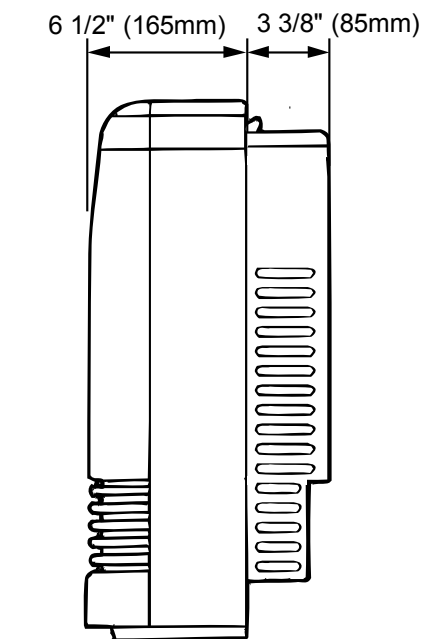





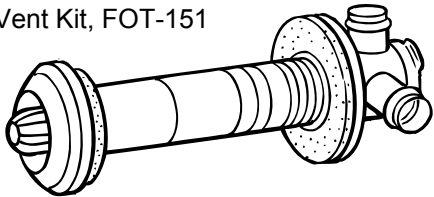

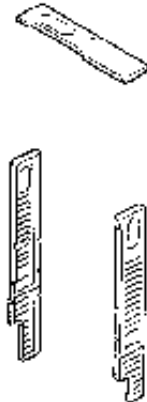
556F-2086

バーコード

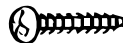

## Installation Parts

The following items are included with the appliance:

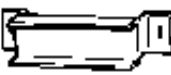
Flue Manifold .....1 "A" Vent Kit, FOT-151 		Spare rubber seal .....1 ('A' Flue units only)  (For weatherboard installations)			
Back Spacer Set		1	Spacer Bracket		1
			Pipe Stopper		1
			Manual Valve Set		1
			Screw	 (For Clamp)	2
Insulation Clip		1	Screw	 (For Wall Bracket and Flue manifold)	5
Plastic tie for air inlet		1	Screw	 (For Back Spacer)	10
Clamp		2	Screw	 (For Flue Manifold)	3
Wall Bracket		1	Owner's Manual Conversion Manual Conversion Kit		1

The following flue manifold sizes are available for different wall thicknesses:

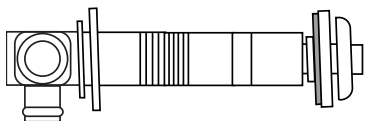

Name	Kit No.	fits walls
S Vent Kit	FOT-150	3 - 4 1/2 in (75 - 115 mm)
A Vent Kit	FOT-151	4 1/2 - 9 1/2 in (115 - 240 mm)
B Vent Kit	FOT-152	9 1/2 - 15 3/4 in (240 - 400mm)
C Vent Kit	FOT-153	15 3/4 - 23 5/8 in (400 - 600 mm)
D Vent Kit	FOT-154	23 5/8 - 31 1/2 in (600 - 800 mm)

## Drilling Flue Hole

---

Ensure that there are no gas or water lines, or electrical circuits in the wall location where the flue hole is to be drilled.

Drill the flue hole using a 3 1/8 inch (80 mm) drill. The center of the hole must be located anywhere within the shaded area, unless extension kits are used. See diagram.

For weatherboard walls, drill through the center of the weatherboard from the outside first and then through the plasterboard. A template is provided.

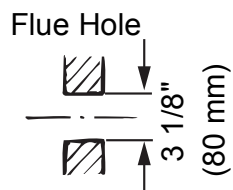

For installation without using extension kits, the configuration of the flue manifold, air intake hose, and exhaust slide pipe should be as shown when installation is completed. The shaded area shows where the flue manifold can be located.

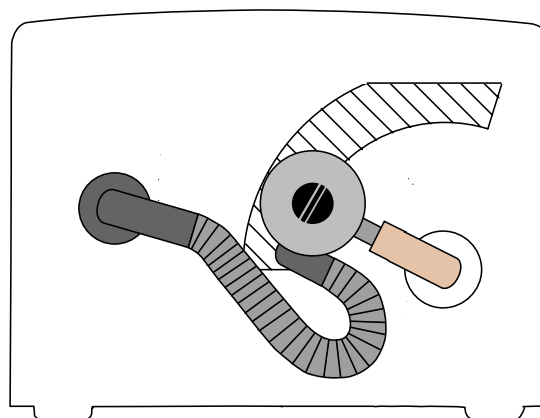

**Configuration viewed from behind the appliance.**

## Flue Manifold Installation

- The flue manifold must exhaust to the outside. Do not exhaust into other rooms.
- The flue manifold is not designed to be positioned under floors or below the heater.
- The termination cannot be vertical.
- This appliance can only be used with one of the five types of Rinnai flue kits. The flue kits and their dimensions are listed on the previous page.
- Refer to the Flue Terminal Clearances section.

### 1. Disassemble the flue manifold

The flue consists of 3 parts:

- sleeve
- inside connection
- outside terminal

Disassemble the flue manifold by first pulling out the inside connection. To remove the outer terminal pull and release the two internal ties and then pull out the outer terminal.

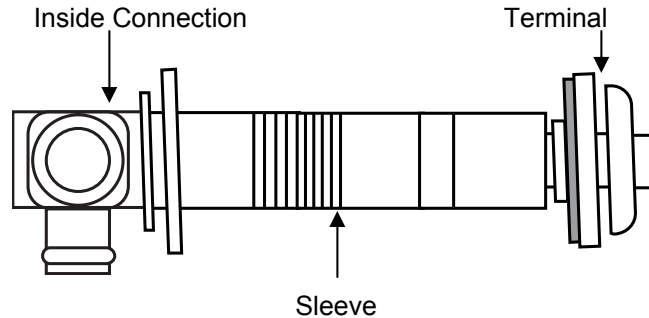

Clearance to combustibles for the sleeve and flanges is zero inches.

### 2. Adjust the sleeve length

Measure wall thickness through previously drilled 3 1/8 inch (80 mm) hole.

The end of the sleeve should protrude 3/16 - 3/8 inch (5-10 mm) from the outside wall.

The sleeve is threaded for adjustment. Adjust the sleeve length to wall thickness plus 3/16 - 3/8 inch (5-10 mm).

NOTE: Do not extend beyond the red line.

For other than the "S" type flue manifold, if a shorter length is necessary an extension can be removed. Cut the plastic and remove the extension.

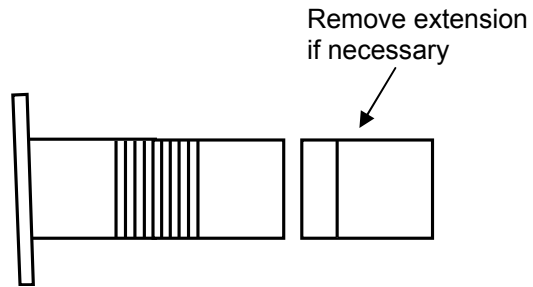

### 3. Attach the sleeve

Attach to the inside wall using 3 screws arranging the flange so that the marking "TOP" is at the top.

The flange is offset 2° to allow the condensate drain to the outside.

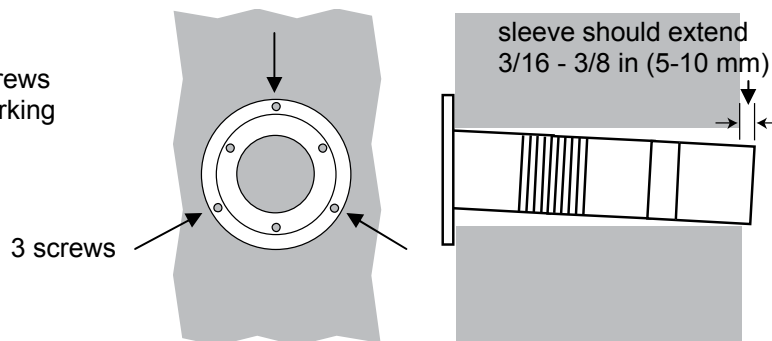

## Flue Manifold Installation

---

### 4. Install the Terminal

Check that the terminal seal is in place. For weatherboard walls, add the second seal next to the terminal seal to compensate for weather board angle.

From the outside insert the terminal into the sleeve with the marking "TOP" at the top. The left hand side locking tie should be marked "LEFT".

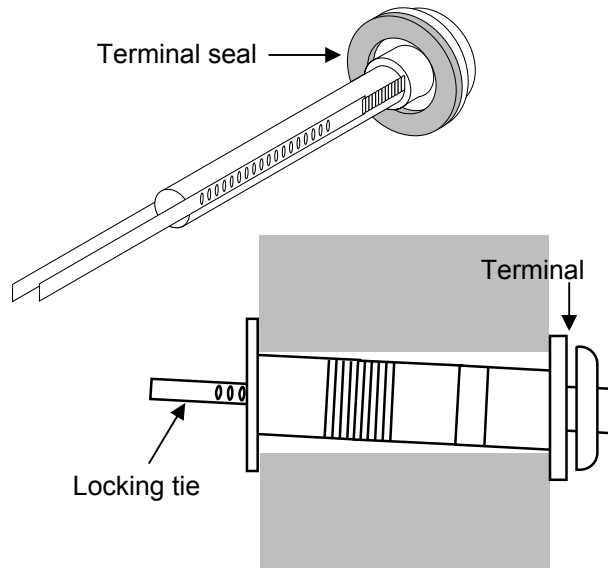

### 6. Lock the ties

Pulling hard on the left and right hand ties, clip the ties over the notches inside the sleeve. You should be able to pull the ties 2 or 3 notches past the starting point. Cut the ties, leaving about 3/4 inch (20 mm) past the notch. Bend the ties back into the sleeve and parallel to the wall.

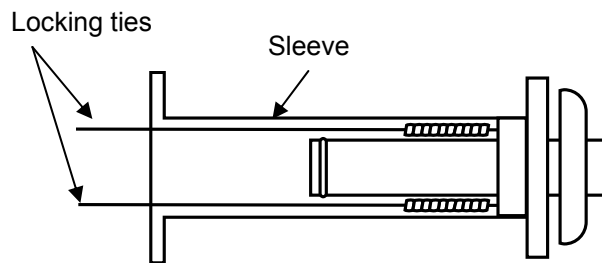

### 7. Insert Inside Connection Assembly

Push the assembly into the terminal tube, ensuring that the seal is in place on the inner tube.

Attach the inside connection with 3 screws. The inner connection can still be turned to install the screws.

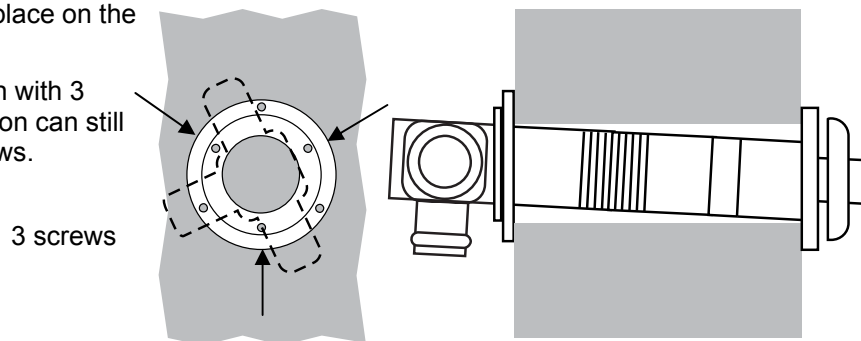

## Extension Kit Installation

If necessary, extension kits are available to extend the exhaust line and air intake hose between the manifold and the appliance.

- (1) Maximum vent length allowed is 13 feet (4 m).
- (2) Maximum vertical length allowed is 8 feet (2.4 m).
- (3) Any length (horizontal and vertical) in excess of 8 feet (2.4 m) must be sloped 3° downward toward the flue manifold to allow condensate to drain to the outside.
- (4) Do not allow any low points in the exhaust line where condensate will collect.
- (5) Vent extensions installed in unconditioned air space must be insulated with high temperature insulation and must be accessible.
- (6) Vent extensions must not be concealed per NFPA 54 and must be accessible allowing inspection and repair. Decorative covers are available from Rinnai.

These figures show the 3 possible ways that the extension exhaust line and air intake hose may be directed away from the appliance. All 3 views are from behind the appliance.

**For your configuration, position the air intake hose as shown.**

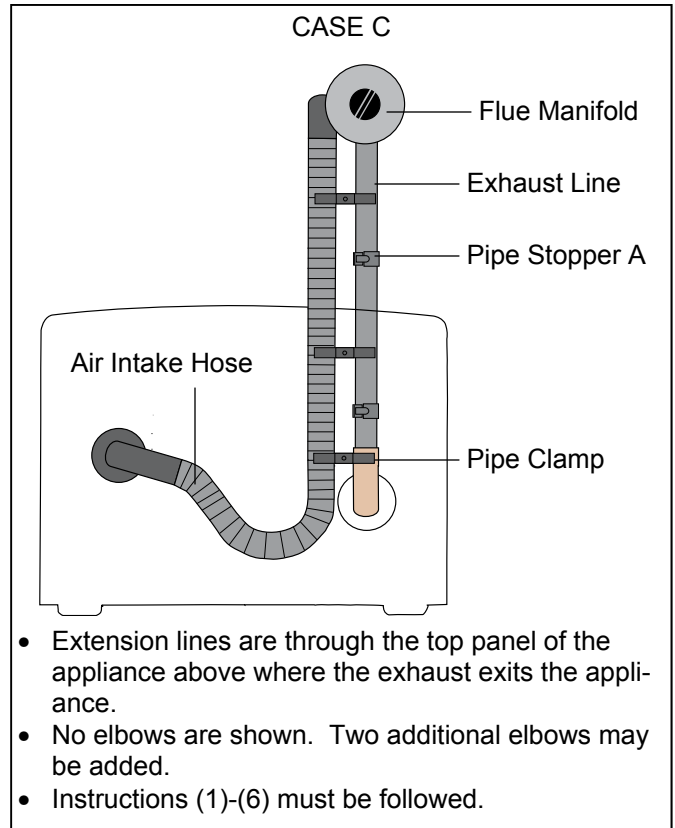
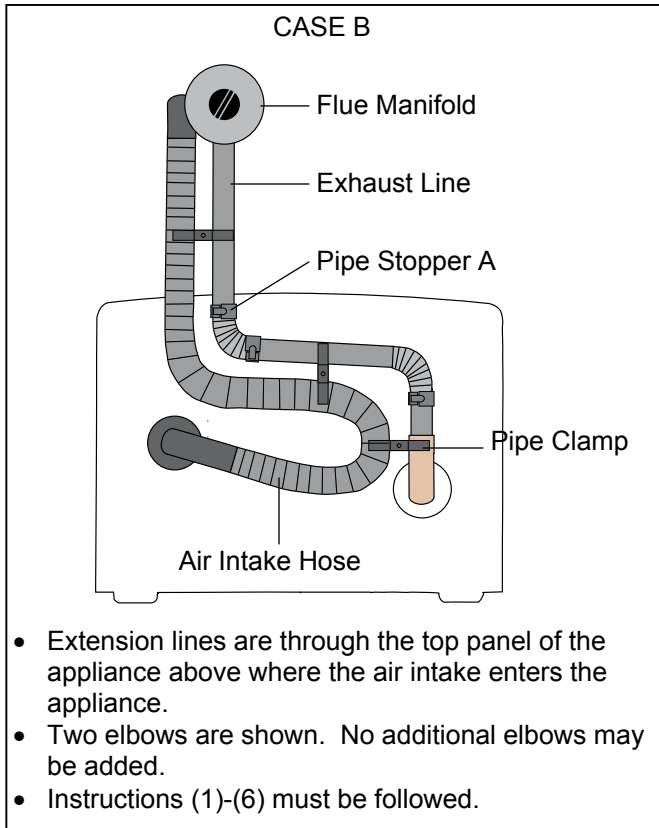
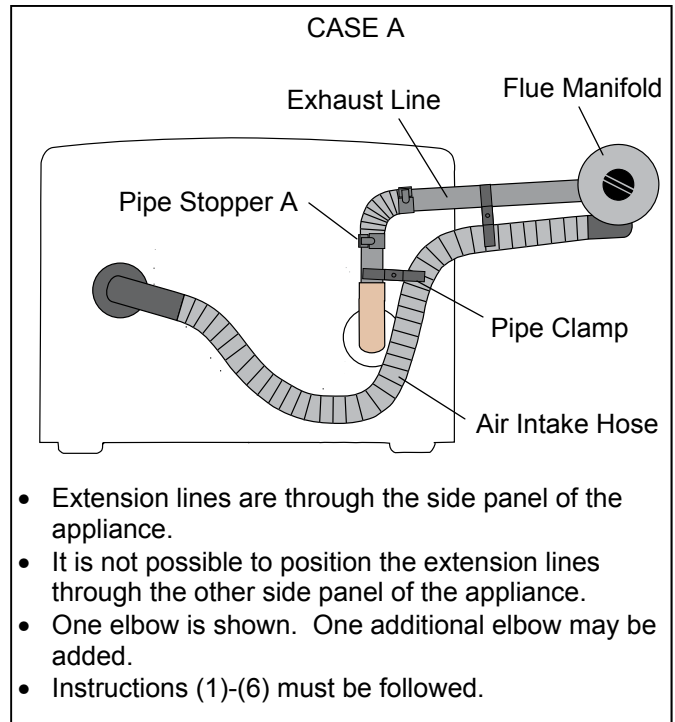

## Extension Kit Installation

**CAUTION** Use the pipe stoppers, connectors, clamps, and screws according to these instructions in order to ensure no leakage of exhaust gases.

### Clearances

exhaust pipe to combustibles	1 inch (25.4 mm)
exhaust pipe to non-combustibles	zero

### Clamps

Both the exhaust line and air intake hose are supported by clamps which are attached to the wall. A wall fixture can be used to offset the clamp from the wall. Use Screw B to attach the wall fixture to the wall. If the wall fixture is not used then use Screw A and the nut to attach the clamp to the wall.

The air intake hose should always be underneath the exhaust line so that in case the air intake hose sags it will not come into contact with the exhaust line.

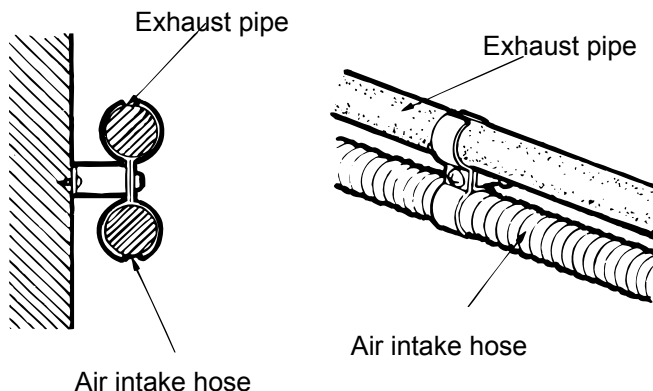

### Installing the Exhaust Line

The exhaust line is connected between the bent pipe at the rear of the heater and the exhaust port on the flue manifold.

To connect exhaust pipes with other straight pipes or bends, fit the male end into the female end. Use pipe stopper A to clamp the connection.

Use pipe stopper B to fix the length on the adjustable exhaust pipes. Do not extend these pipes beyond the red line.

Do not cut the exhaust pipe. Use the adjustable pipes if necessary.

To bend the elbow, insert exhaust pipes into both ends for additional leverage. Bend to desired angle.

Do not straighten the bent pipe attached to the appliance.

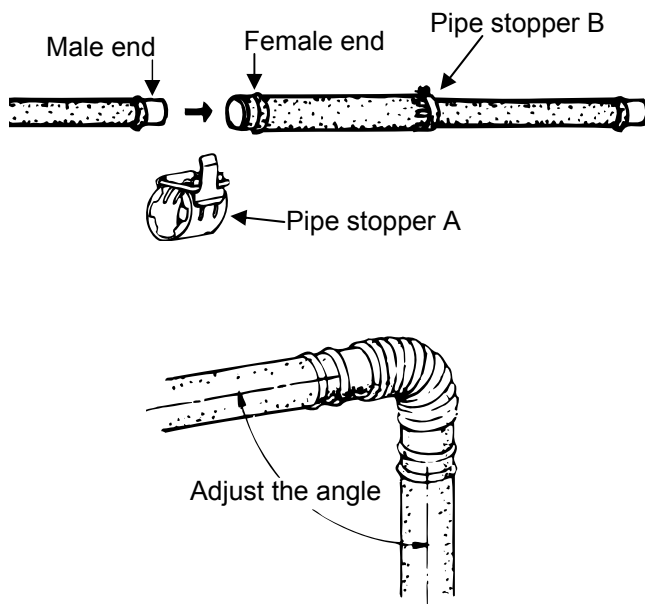

### Connecting the Air Intake Hose

The air intake hose is connected between the air connection at the rear of the heater and the air intake port on the flue manifold.

Push the air intake hose onto the flue manifold and secure with the plastic cable tie.

Join air intake hoses by screwing the hose joint half of its length into the air intake hose and then screwing another air intake hose into the hose joint.

The lengths of the air intake hose and the exhaust pipe must be the same in order for the appliance to operate properly. The hose can be cut to the required length. Deburr all rough edges. Do not cut the hose attached to the appliance.

Support the air intake hose with pipe clamps.

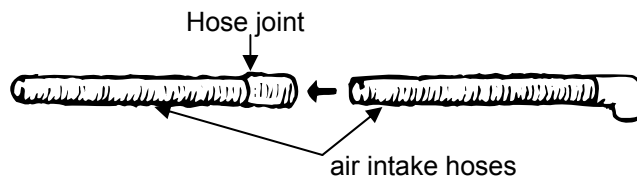

## Extension Kit Installation

### Extension Kits and Parts



① EXHAUST PIPE (ADJUSTABLE)

② EXHAUST PIPE (NON ADJUSTABLE)

③ AIR INTAKE HOSE

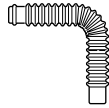

④ BENT ELBOW

⑤ LONG BENT ELBOW

⑥ HOSE JOINT

⑦ PIPE STOPPER A

⑧ PIPE STOPPER B



⑨ PIPE CLAMP

⑩ WALL-FIXTURE

⑪ NUT

⑫ SCREW A

⑬ SCREW B

Item	Description	FOT-219	FOT-220	FOT-221	FOT-158	FOT-190
1	Exhaust Pipe (adjustable) 11.4-20.3 in (290-515 mm)	1				
1	Exhaust Pipe (adjustable) 21.0-39.6 in (533-1005 mm)		1	1		
2	Exhaust Pipe - 40 in (1016 mm)			1		
3	Air Intake Hose - 29.5 in (750 mm)	1				
3	Air Intake Hose - 49.2 in (1.25 m)		1			
3	Air Intake Hose - 90.6 in (2.3 m)			1		
4	Bent Elbow				1	
5	Long Bent Elbow					1
6	Hose Joint	1	1	1		
7	Pipe Stopper A	1	1	2	1	1
8	Pipe Stopper B	1	1	1		
9	Pipe Clamp	2 sets	3 sets	4 sets		
10	Wall Fixture	2	3	4		
11	Nut	2	3	4		
12	Screw A	2	3	4		
13	Screw B	4	6	8		

## Connecting the Appliance

1. Attach the air inlet hose to the flue manifold on either inlet position "a" or "b".

The unused inlet is plugged with the rubber cap supplied on the manifold.

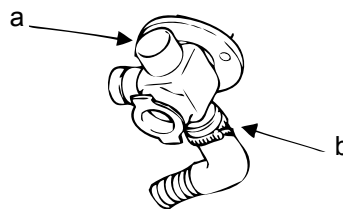

2. Connect the flue elbow to the manifold while moving the appliance into position.

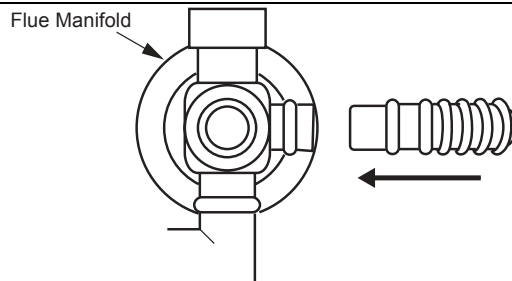

3. Fit the pipe stopper over the connection between the flue elbow and the manifold. Engage the hook and rotate it until it snaps against the body of the clamp.

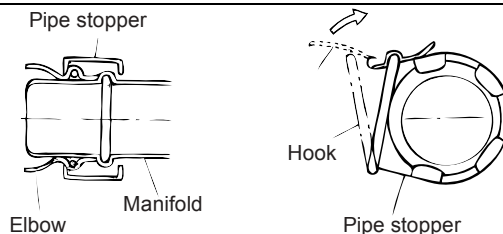

4. Slide the insulation sleeve up to the flue manifold and slip the securing clip over the sleeve as shown.

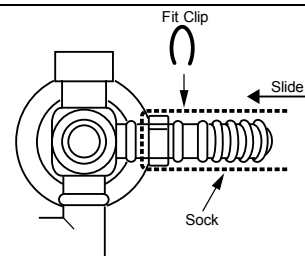

5. Install the bracket on the rear of the top spacer by tightening 2 screws.

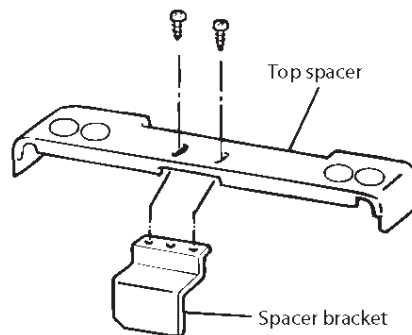

6. Install the wall bracket with two screws. Install the top spacer by clipping the spacer into the wall brackets and attaching it to the heater with 2 screws.

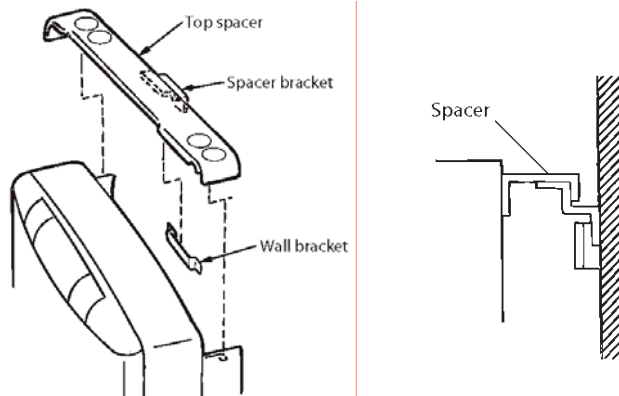

## FOR YOUR SAFETY READ BEFORE OPERATING





### WARNING

If you do not follow these instructions exactly, a fire or explosion may result causing property damage, personal injury or loss of life.

- A. This appliance does not have a pilot. It is equipped with an ignition device which automatically lights the burner. Do not try to light the burner by hand.
- B. **BEFORE OPERATING** smell all around the appliance area for gas. Be sure to smell next to the floor because some gas is heavier than air and will settle on the floor.
  - WHAT TO DO IF YOU SMELL GAS
    - Do not try to light any appliance.
    - Do not touch any electric switch; do not use any phone in your building.
    - Immediately call your gas supplier from a neighbor's phone. Follow the gas supplier's instructions.
- If you cannot reach your gas supplier, call the fire department.
- C. Use only your hand to push in or turn the gas control knob. Never use tools. If the knob will not push in or turn by hand, do not try to repair it, call a qualified service technician. Force or attempted repair may result in a fire or explosion.
- D. Do not use this appliance if any part has been under water. Immediately call a qualified service technician to inspect the appliance and to replace any part of the control system and any gas control which has been under water.

## OPERATING INSTRUCTIONS

1. **STOP!** Read the safety information above.
2. Set the thermostat to lowest setting.
3. Turn off all electric power to the appliance using the ON/OFF button.
4. This appliance is equipped with an ignition device which automatically lights the burner. Do not try to light the burner by hand.
5. Locate the manual gas valve on the side of the heater. Turn the manual valve clockwise to the full OFF position. 
6. Wait five (5) minutes to clear out any gas. Then smell for gas, including near the floor. If you smell gas, STOP! Follow "B" in the safety information above. If you don't smell gas, go to the next step.
7. Turn the manual gas valve counterclockwise to the full ON position. 
8. Turn on all electric power to the appliance using the ON/OFF button.
9. Set the thermostat to desired setting.
10. Combustion indicator glows red when the burner is lit and flashes when the burner fails to ignite. If the appliance will not operate, follow the instructions "To Turn Off Gas To Appliance" and call your service technician or gas supplier. See manual for additional information.

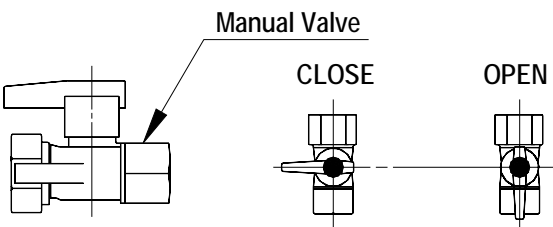

## TO TURN OFF GAS TO APPLIANCE

1. Set the thermostat to lowest setting.
2. Turn off all electric power to the appliance using the ON/OFF button.
3. Locate the manual gas valve on the side of the heater. Turn the manual valve clockwise to the full OFF position. 

NOTE: The fan will continue to operate until the appliance is cool. Do not turn the appliance off by unplugging it from the wall. Keep burner and control compartment clean. See installation and operating instructions.

# Cut-Away Diagram

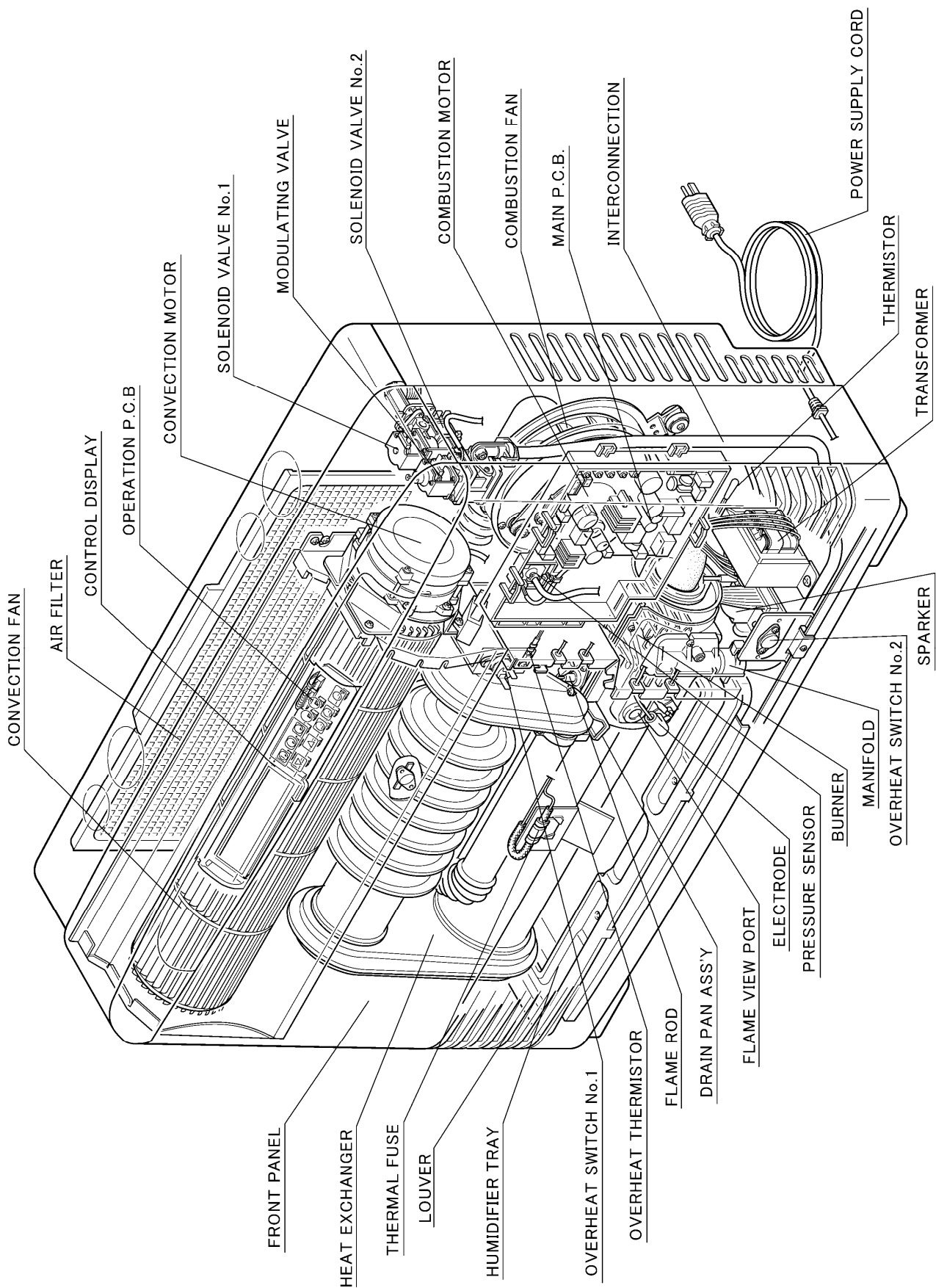

# Wiring Diagram

## CAUTION

Label all wires prior to disconnection when servicing controls. Wiring errors can cause improper and dangerous operation.

If any of the original wire as supplied with the appliance must be replaced, it must be replaced with type 18 AWG wire or its equivalent.

MARK	PART NAME	MARK	PART NAME
MS	MAIN SWITCH	OH.TH	OVER HEAT THERMISTOR
R.TH	THERMISTOR	OHS1, 2, 3	OVER HEAT SWITCH 1, 2, 3
TF	THERMAL FUSE	FM	CONVECTION FAN MOTOR
F	FUSE	SP	SPARKER
ER	ELECTRODE	SV1, 2	MAIN SOLENOID VALVE 1, 2
POV	MODULATING SOLENOID VALVE	BL	COMBUSTION FAN MOTOR
TR	TRANSFORMER	PS	PRESSURE SENSOR
FR	FLAME ROD		

CODE	COLOR
bk	black
bl	blue
gr	green
gr/y	green/yellow
r	red
w	white
y	yellow
gy	gray
or	orange

## WIRING DIAGRAM

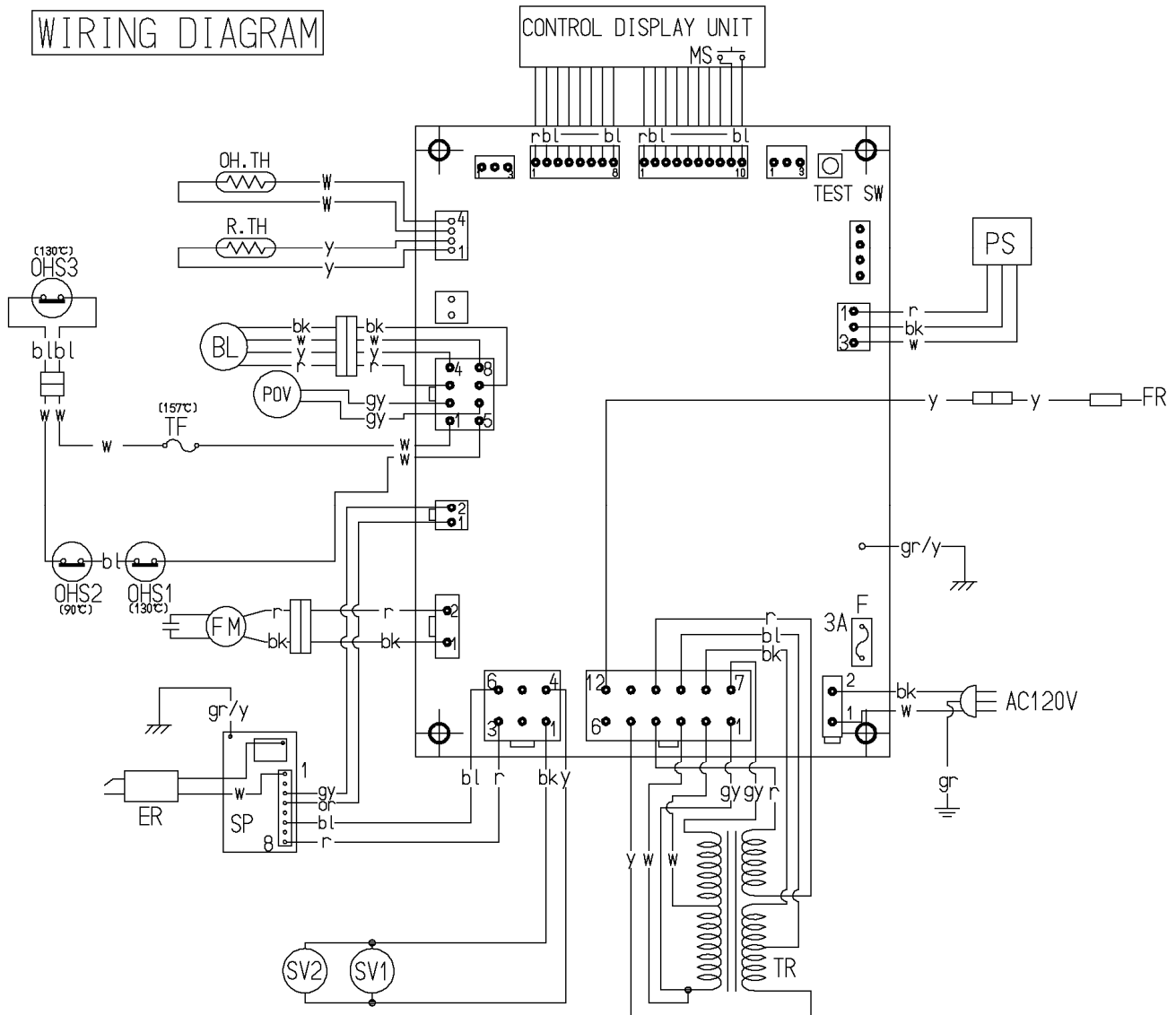



# Flow Diagram

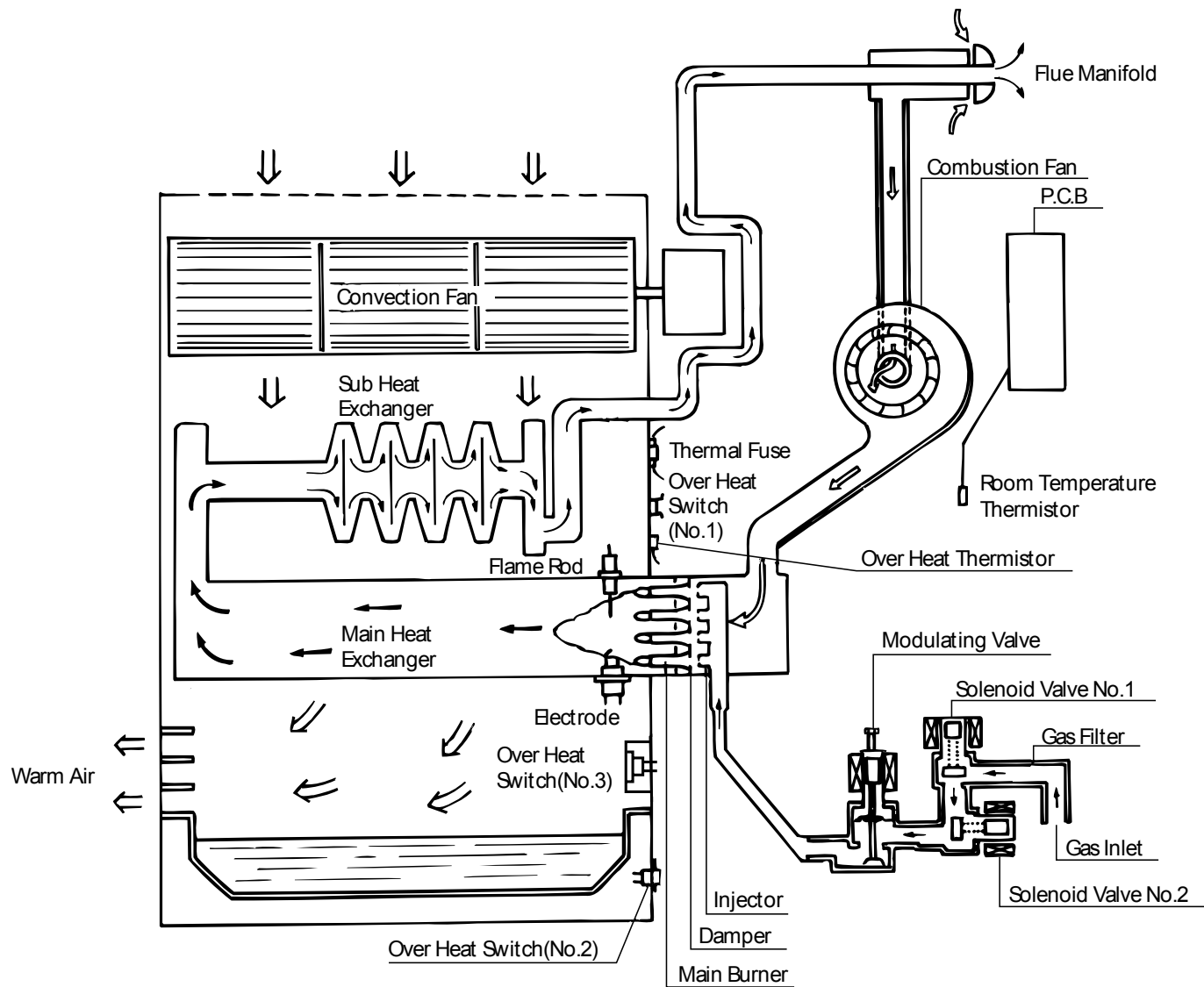

# Parts List

For replacement parts call Rinnai at 1-800-621-9419.

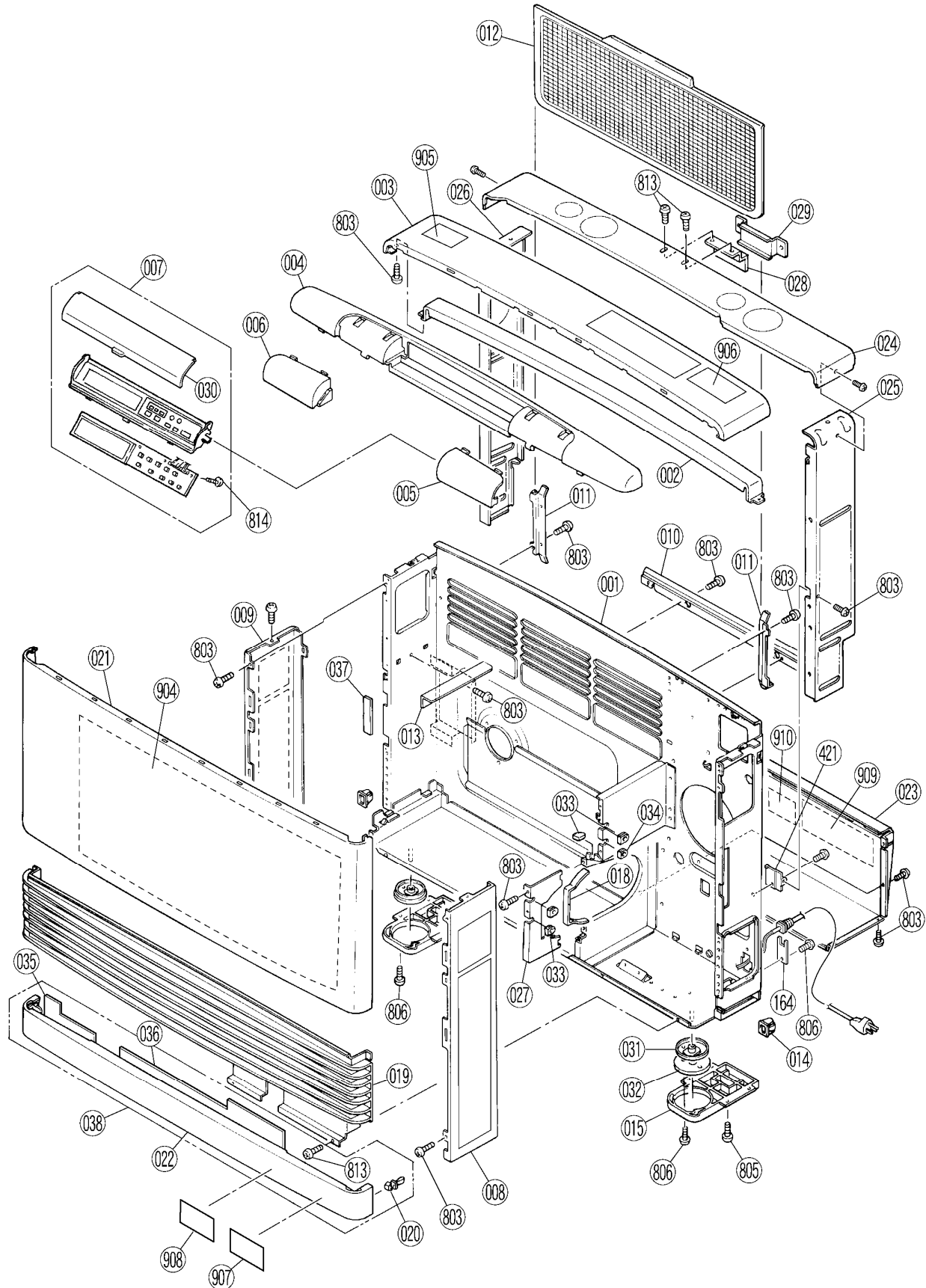

# Parts List

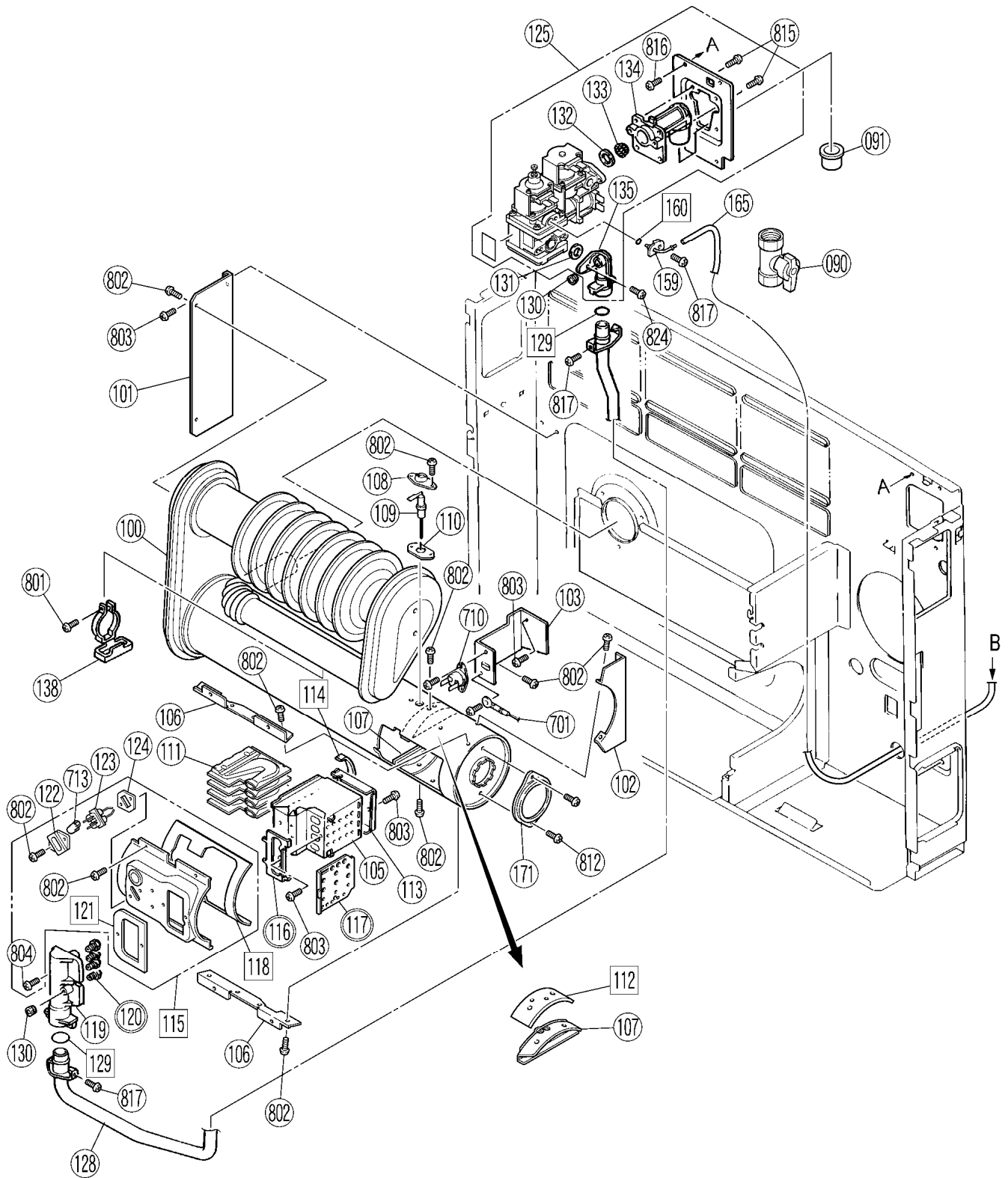

# Parts List

For replacement parts call Rinnai at 1-800-621-9419.

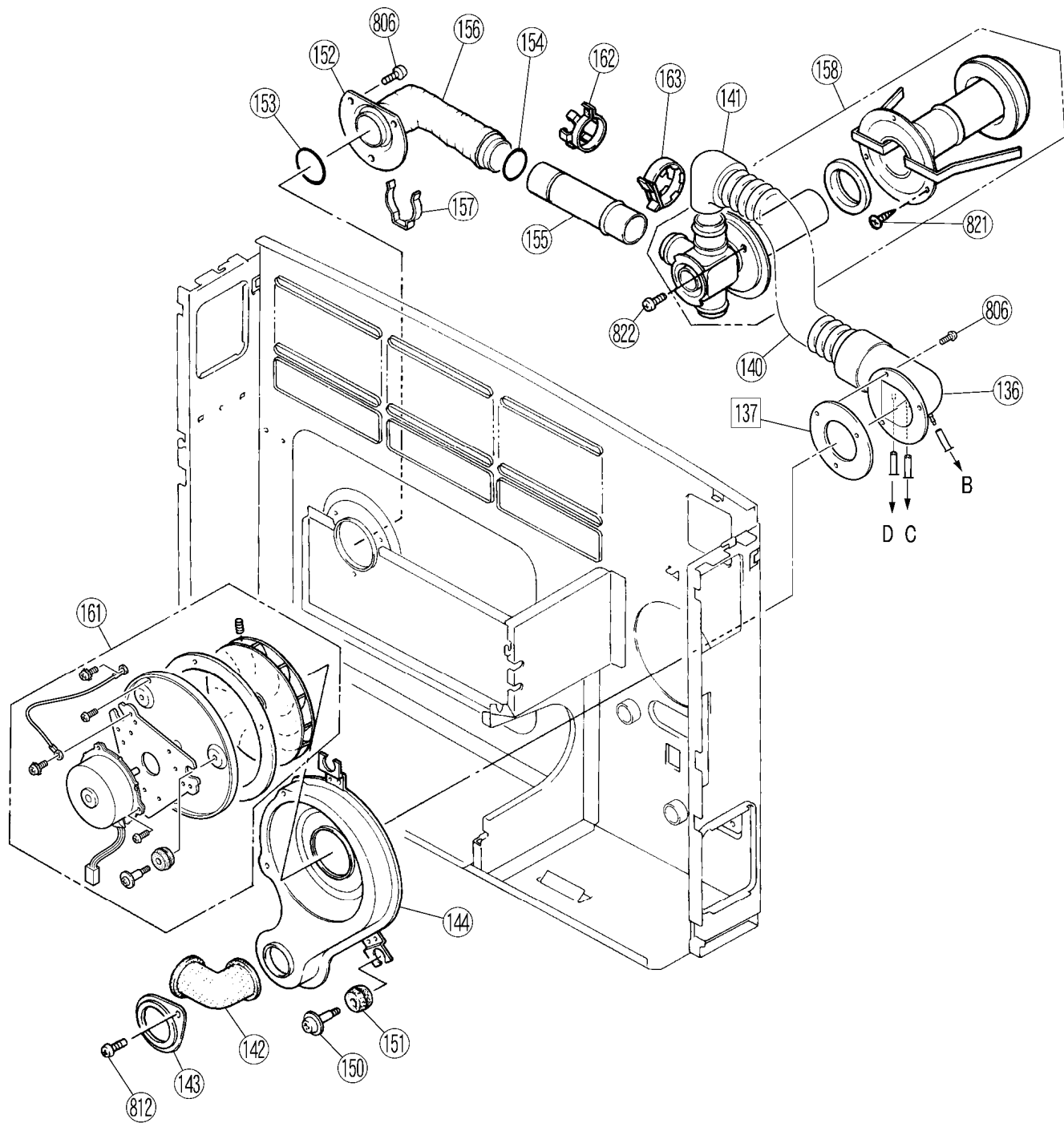



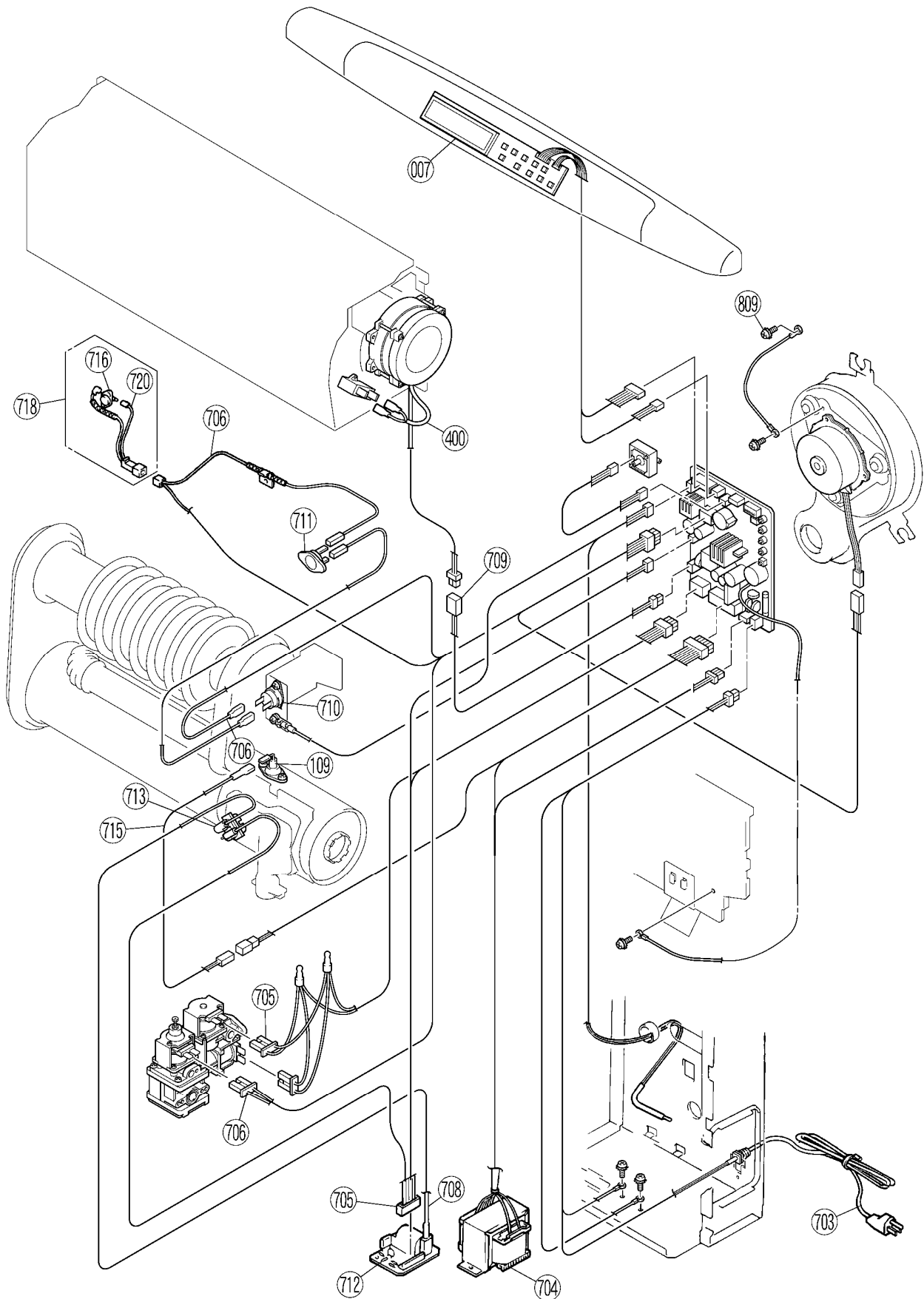

## Parts List

---

ITEM	PART NUMBER	PART NAME	QTY
001			
002			
003			
004			
005			
006			
007			
008			
009			
010			
011			
012			
013			
014			
015			
016			
017			
018			
019			
020			
021			
022			
023			
024			
025			
026			
027			
028			
029			
030			
031			
100			
101			
102			
103			
104			
105			
106			
107			
108			
109			
110			
111			
112			
113			
114			
115			

*Parts List*

---

ITEM	PART NUMBER	PART NAME	QTY
116			
117			
118			
119			
120			
121			
122			
123			
124			
125			
126			
128			
129			
130			
131			
132			
133			
134			
135			
136			
137			
138			
139			
140			
141			
142			
143			
144			
145			
146			
147			
148			
149			
150			
151			
152			
153			
300			
301			
302			
400			
401			
402			
403			
404			
405			
406			

## Parts List

---

ITEM	PART NUMBER	PART NAME	QTY
407			
408			
409			
700			
701			
702			
703			
704			
705			
706			
707			
708			
709			
710			
711			
712			
713			
714			
715			
716			
717			
718			
800			
801			
802			
802			
803			
803			
804			
805			
806			
806			
807			
808			
809			
810			
811			
812			
813			
813			
814			
815			
815			
900			
901			
902			
904			

# Consumer Support

## Warranty Information

The installer is responsible for your heater's correct installation.

Please complete the information below to keep for your records:

Purchased from: \_\_\_\_\_

Address: \_\_\_\_\_ Phone: \_\_\_\_\_  
\_\_\_\_\_

Date of Purchase: \_\_\_\_\_

Model No.: \_\_\_\_\_

Serial No.: \_\_\_\_\_

Installed by: \_\_\_\_\_ Installer's License No.: \_\_\_\_\_

Address: \_\_\_\_\_ Phone: \_\_\_\_\_

Date of Installation: \_\_\_\_\_

## Limited Warranty

### Gas Direct Vent Wall Furnace

#### What is covered?

This Warranty covers any defects in materials or workmanship, subject to the terms stated below. This Warranty extends to the original purchaser and subsequent transferees, but only while the product remains at the site of the original installation. This Warranty only extends through the first installation of the product and terminates if the product is moved or reinstalled at a new location.

#### How long does coverage last?

Item	Period of Coverage
Heat Exchanger	10 years from date of purchase *
All Other Parts	5 years from date of purchase
Reasonable Labor	2 years from date of purchase

#### What will Rinnai do?

Rinnai will repair or replace the covered product or any part or component that is defective in materials or workmanship as set forth. Rinnai will pay reasonable labor charges associated with the repair or replacement of any such part or component. All repair parts must be genuine Rinnai parts. All repairs or replacements must be performed by an individual or servicing company that is properly trained, state qualified or licensed to do the type of repair.

## Limited Warranty - continued

Replacement of the product may be authorized by Rinnai only. Rinnai does not authorize any person or company to assume for it any obligation or liability in connection with the replacement of the product. If Rinnai determines that repair of a product is not possible, Rinnai will replace the product with a comparable product at Rinnai's discretion. If a component or product returned to Rinnai is found to be free of defects in material or workmanship, or damaged by improper installation or damaged during return shipping, the warranty claim for product, parts and labor may be denied.

- \* If the Heat Exchanger fails due to a defect in material or workmanship within the sixth (6) through the tenth (10) year from the date of purchase, Rinnai will make the following allowances toward the purchase of a replacement Heat Exchanger:

Heat Exchanger	
Year of Failure	Allowance
6	50%
7	40%
8	30%
9	20%
10	10%

### How do I get service?

You must contact a state qualified/licensed contractor or authorized service provider for the repair of a product under this Warranty. For the name of a qualified/authorized service provider please contact your place of purchase, visit the Rinnai website ([www.rinnai.us](http://www.rinnai.us)), call Rinnai at 1-800-621-9419 or write to Rinnai at 103 International Drive, Peachtree City, Georgia 30269.

Proof of purchase is required to obtain warranty service. You may show proof of purchase with a dated sales receipt, or by registering within 30 days of purchasing the product. To register your appliance, please visit [www.rinnairegistration.com](http://www.rinnairegistration.com). For those without internet access, please call 1-866-RINNAI1 (745-6241). Receipt of Registration by Rinnai will constitute proof-of-purchase for this product. However, Registration is not necessary in order to validate this Warranty.

### What is not covered?

This Warranty does not cover any failures or operating difficulties due to the following:

- accident, abuse, or misuse
- alteration
- misapplication
- force majeure
- improper installation (such as but not limited to, condensate damage, improper venting, incorrect gas type, or incorrect gas pressure)
- improper conversion (including conversions for inventory adjustment)
- improper maintenance (such as but not limited to vent blockage)
- incorrect sizing
- any other causes other than defects in materials or workmanship

This Warranty does not apply to any product whose serial number or manufacture date has been defaced.

### Limitation on warranties

No one is authorized to make any other warranties on behalf of Rinnai America Corporation. Except as expressly provided herein, there are no other warranties, expressed or implied, including, but not limited to warranties of merchantability or fitness for a particular purpose, which extend beyond the description of the warranty herein and further Rinnai shall not be liable for indirect, incidental, special, consequential or other similar damages that may arise, including lost profits, damage to person or property, loss of use, inconvenience, or liability arising from improper installation, service or use. Some states do not allow the exclusion or limitation of incidental or consequential damages, so the above limitation may not apply to you.

Any implied warranties of merchantability and fitness arising under state law are limited in duration to the period of coverage provided by this limited Warranty, unless the period provided by state law is less. Some states do not allow limitations on how long an implied Warranty lasts, so the above limitation may not apply to you.

This Warranty gives you specific legal rights, and you may also have other rights which vary from state to state.

# Notes

## Notes

# Ask about **Rinnai**

## Rinnai's other fine products

Rinnai America Corporation  
103 International Drive  
Peachtree City, GA 30269  
TOLL FREE: 1-800-621-9419  
[www.rinnai.us](http://www.rinnai.us)



### Tankless Water Heaters

- Residential and Commercial Applications
- Continuous Hot Water
- Up to 9.8 GPM
- High Energy Efficiency
- Propane or Natural Gas
- Internal or External Installation
- Digital Temperature Control
- Small, Compact Design



### Direct Vent Furnaces

- High Efficiency
- Cool-to-the-touch Cabinet
- Blower Included
- Vent Terminal A Included
- Gas Conversion Kit Included



### Direct-Vent Fireplace, RHFE-750ETR

- Up to 83% AFUE Energy Efficiency
- Zero-Clearance Installation
- Available in Four Options of Fronts
- Remotes and Fan Included
- Gas Conversion Kit Available



### Hydronic Air Handler

- Designed for Use with Rinnai Systems
- Domestic Hot Water Priority
- Optional Programmable Thermostat
- Zero Clearance to Combustibles
- Accommodates Standard Cased-Coils

Register your product at [www.rinnairegistration.com](http://www.rinnairegistration.com)  
or call 1-866-RINNAI1 (746-6241)