



RHFE-201FA

Energysaver

Gas Direct Vent Wall Furnace

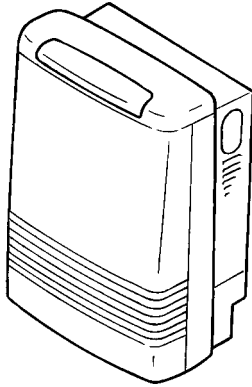

Table of Contents	2
Safety Information.....	3
Operating Instructions.....	6
Care and Maintenance....	10
Fault Codes	13
Installation Instructions ...	14
Consumer Support.....	36

WARNING: If the information in these instructions is not followed exactly, a fire or explosion may result causing property damage, personal injury or loss of life.

— Do not store or use gasoline or other flammable vapors and liquids in the vicinity of this or any other appliance.

— **WHAT TO DO IF YOU SMELL GAS**

- Do not try to light any appliance.
- Do not touch any electrical switch; do not use any phone in your building.
- Immediately call your gas supplier from a neighbor s phone. Follow the gas supplier s instructions.
- If you cannot reach your gas supplier, call the fire department.

— Installation and service must be performed by a qualified installer, service agency or the gas supplier.

INSTALLER: Leave this manual with the appliance.
CONSUMER: Retain this manual for future reference.

Register your product at www.rinnairregistration.com or call 1-866-RINNAI1 (746-6241)

Rinnai[®]

This appliance may be installed as an OEM installation in a manufactured home (USA only) or mobile home and must be installed in accordance with the manufacturer's instructions and the *Manufactured Home construction and Safety Standard, Title 24 CFR, Part 3280*, in the United States, or the *Mobile Home Standard, CAN/CSA Z240 MH Series*, in Canada. This appliance is only for use with types of gas indicated on the rating plate. A conversion kit is supplied with the appliance.

This appliance may be installed in an aftermarket, permanently located, manufactured home (USA only) or mobile home, where not prohibited by local codes.

This appliance is only for use with the type of gas indicated on the rating plate. This appliance is not convertible for use with other gases, unless a certified kit is used.

This equipment is made for use as a heater in a residential building or a light commercial building. Do not use in locations where there are spray, chemicals, or large amounts of dust. Using hair treatment products containing silicon may cause ignition error, flame extinction, or other malfunctions.

Table of Contents

Consumer Safety Information		<i>Before Making a Service Call</i>	11
<i>Safety Definitions</i>	3	<i>Troubleshooting</i>	12
<i>Safety Behaviors and Practices</i>	3	<i>Fault Codes</i>	13
<i>Safety Features</i>	4		
Specifications		Installation Instructions	
<i>Appliance Specifications</i>	4, 5	<i>General Instructions</i>	14
<i>Features</i>	5	<i>Gas Connection</i>	15
<i>Flue Manifolds</i>	5	<i>Clearances to Combustibles</i>	15
		<i>Installation Parts</i>	16
Operating Instructions		<i>Drilling Flue Hole</i>	17
<i>Getting to Know your RHFE-201</i>	6	<i>Dimensions</i>	17
<i>Control Panel</i>	7	<i>Flue Terminal Clearances</i>	18, 19
<i>Operating Information</i>		<i>Flue Manifold Installation</i>	20, 21
Turning ON and OFF.....	8	<i>Connecting the Appliance</i>	22
Adjusting the temperature.....	8	<i>Operating Instructions</i>	23
Economy Mode.....	8	<i>Cut-Away Diagram</i>	24
Function Lock.....	9	<i>Wiring Diagram</i>	25
Adding Water to the Humidifier.....	9	<i>Ladder Diagram</i>	26
Adjusting Air Flow Direction.....	9	<i>Flow Diagram</i>	27
Sensible Temperature Control.....	9	<i>Parts List</i>	28-35
<i>Care and Maintenance</i>		Consumer Support	
Maintenance.....	10	<i>Warranty Information</i>	36
Care of Exterior.....	10	<i>Limited Warranty</i>	36,37
Snow Accumulation.....	10		
Filters.....	10		
Visual Inspection of Flame.....	10		

Consumer Safety Information

Safety Definitions



This is the safety alert symbol. This symbol alerts you to potential hazards that can kill or hurt you and others.

DANGER

Indicates an imminently hazardous situation which, if not avoided, will result in death or serious injury.

WARNING

Indicates a potentially hazardous situation which, if not avoided, could result in death or serious injury.

CAUTION

Indicates a potentially hazardous situation which, if not avoided, could result in minor or moderate injury. It may also be used to alert against unsafe practices.

Safety Behavior and Practices

WARNING

- Keep the area around the appliance clear and free from combustible materials, gasoline, and other flammable vapors and liquids.
- Never store liquid propane containers indoors.
- Do not use this appliance if any part has been under water. Immediately call a qualified service technician to inspect the appliance and to replace any part of the control system and any gas control which has been under water.
- This appliance is equipped with a three-prong plug for your protection against shock hazard and should be plugged directly into a properly grounded three-prong receptacle. Do not cut or remove the ground prong from this plug.
- Any alteration to the appliance or its controls can be dangerous.
- Do not operate appliance with the panels removed, cracked or broken. Replacement of the panels should be done by a licensed or qualified service person.

CAUTION

- Do not block the warm air discharge. Do not allow anyone to sleep directly in front of the appliance.
- Due to high temperatures, the appliance should be located out of traffic and away from furniture and draperies.
- Children and adults should be alerted to the hazards of high surface temperature and should stay away to avoid burns or clothing ignition.
- Young children should be carefully supervised when they are in the same room as the appliance.
- Clothing or other flammable material should not be placed on or near the appliance.
- Any safety screen or guard removed for servicing must be replaced prior to operating the appliance.
- Do not insert items into the louvers.
- Do not spray aerosols near the appliance while it is operating. Most aerosols contain butane gas which is flammable.
- Do not unplug the appliance while it is operating or while the fans are on.

Safety Features

- **Overheat:** The appliance will automatically shut down when the appliance exceeds a predetermined temperature.
- **Flame Failure:** The appliance will automatically shut down if the burner flame is extinguished.
- **Power Failure:** The appliance will cut off the gas if it loses electrical power.
- **Power Surge Fuse:** A glass fuse on the PC board protects against overcurrent. If the fuse blows then all indicator lamps will be off.
- **Spark Detector:** The appliance automatically shuts down if there is an abnormal spark at ignition.
- **Fusible Link:** In case the overheat feature prevents the temperature from rising then the fusible link will break shutting off the appliance.

Specifications

Appliance Specifications

Application	For manufactured home (USA only) or mobile home or residential or light commercial installation convertible for use with natural gas and liquefied petroleum gases when provision is made for the simple conversion from one gas to the other.
General Description	Forced combustion, forced convection, flued gas furnace
Operation	Push button electronic
Gas Connection	1/2 in female NPT
Gas Control	Electronic
Burners	Stainless steel Bunsen burner
Temperature Control	Electronic thermostat
Ignition System	Electronic spark ignition
Flue System	The flue must be terminated to atmosphere with only flue components listed with the appliance's certification. Warranty will be voided if non listed components are installed.
Humidifier Tray	Capacity - 1.5 pints (700 cc)
Electrical Connection	AC 120V, 60 Hz, 42 watts
Weight	39.4 lbs (17.9 kg)
Noise Level	27-34 dB
Fan CFM output	Low 48.3 - High 70.6
AFUE Rating	Natural Gas: 80.6% Propane: 83%

Rinnai is continually updating and improving products. Therefore, specifications are subject to change without prior notice.

The efficiency rating of this appliance is a product thermal efficiency rating determined under continuous operating conditions and was determined independently of any installed system.

Appliance Specifications

	Natural Gas	Propane Gas
Minimum supply gas pressure	4.5 in (114 mm) W.C.	8.0 in (203 mm) W.C.
Maximum supply gas pressure	10.5 in (267 mm) W.C.	13.0 in (330 mm) W.C.
Manifold test pressure-Low	0.6 in (15 mm) W.C.	0.9 in (24 mm) W.C.
Manifold test pressure-High	3.3 in (85 mm) W.C.	6.0 in (152 mm)W.C.
BTU/hour input	Low 3000 - High 8000	
BTU/hour output	Low 2400 - High 6400	

Features

- Clean Heating Forced Flue Type
- Easy Operation One-Touch Ignition
- Sensible Temperature Control Feature
- Comfortable Room Temperature Control and Display
- Warm Air Outlet at Floor Level (keeps your feet warm)
- Function Lock
- Room Temperature Setting Memory
- Clean the Air Filter - Indicator Lamp
- Energy Saving Economy Setting
- Humidifier Tray
- Air Flow Directional Louvers
- Direct Vent Easily Installed
- Proportional Heating Variable Capacity
- Hush! Quiet Operation
- Modern Design Minimizes Floor Space Requirements
- Failure Message Display

Flue Manifolds

See the installation instructions for the parts list of the vent kit.

The "A" Vent Kit is included with the appliance.

The following flue manifold sizes are available:

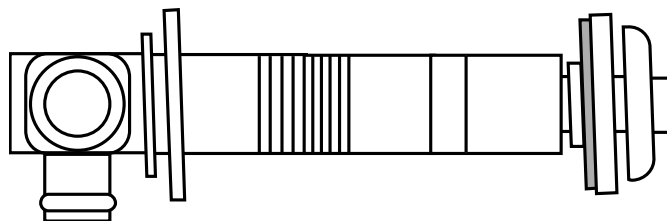

Name	Kit No.	fits walls
S Vent Kit	FOT-150	3 - 4 1/2 in (75 - 115 mm)
A Vent Kit	FOT-151	4 1/2 - 9 1/2 in (115 - 240 mm)
B Vent Kit	FOT-152	9 1/2 - 15 3/4 in (240 - 400mm)
C Vent Kit	FOT-153	15 3/4 - 23 5/8 in (400 - 600 mm)
D Vent Kit	FOT-154	23 5/8 - 31 1/2 in (600 - 800 mm)

Operating Instructions

Getting to know your new RHFE-201

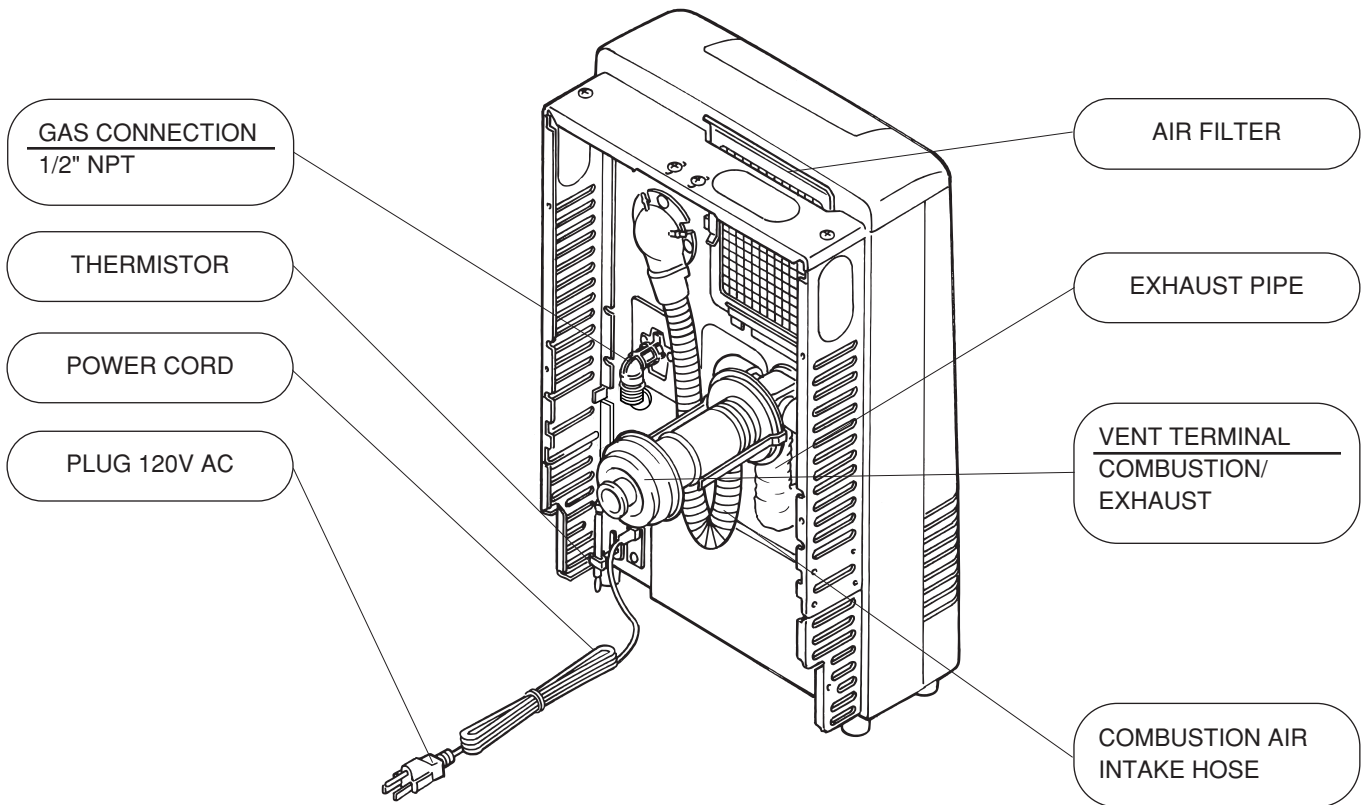
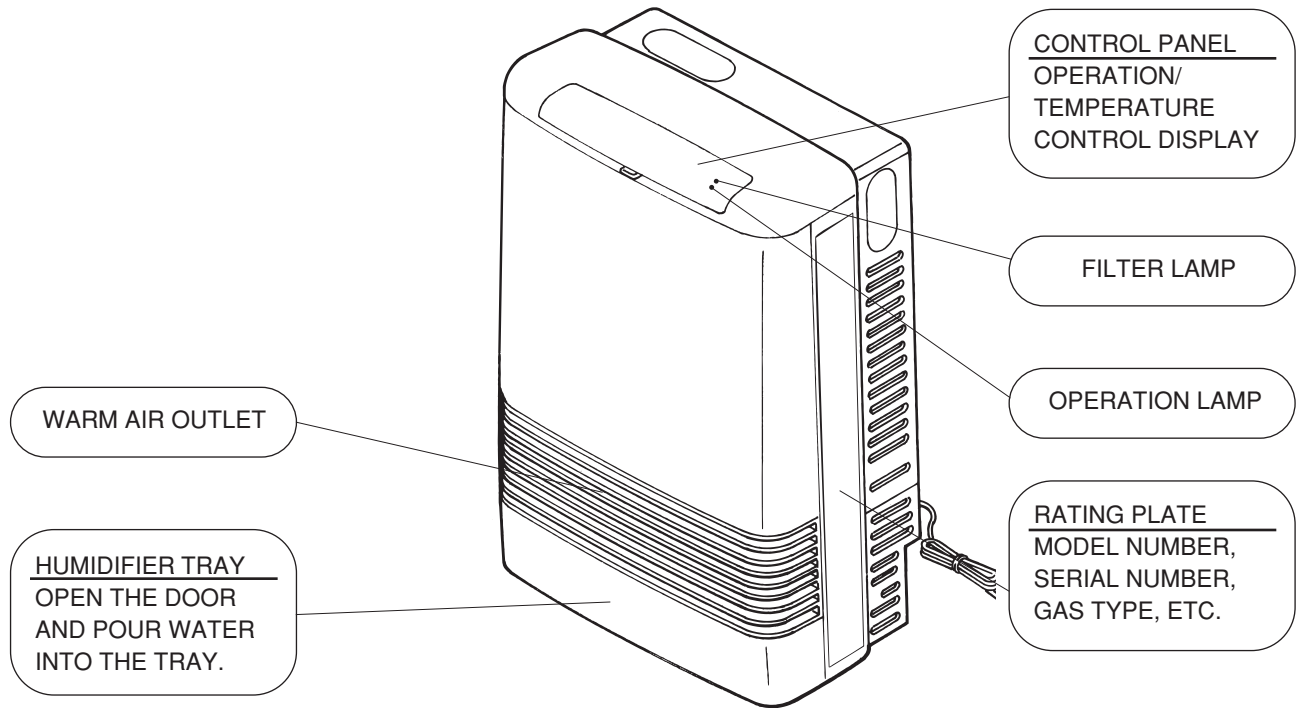

Control Panel

OPERATION LAMP
 This lamp turns "green" when power is on. Lamp will change to "red" when burner is on.

FILTER LAMP
 Flashes when filter is dirty.

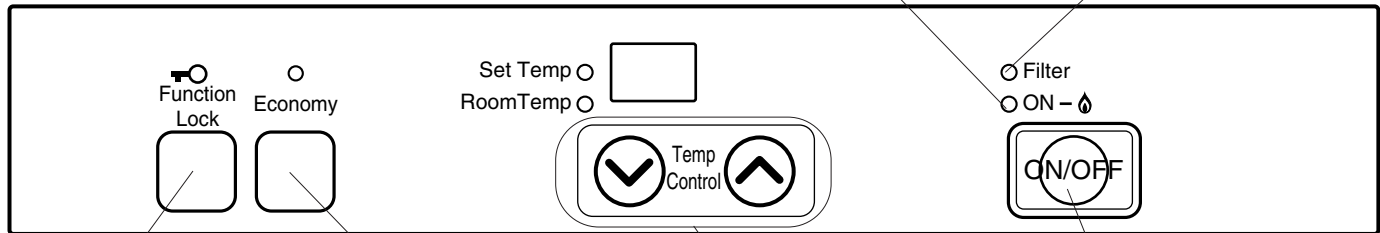

FUNCTION LOCK
 Lamp is "green" when this feature is on.

ENERGY SAVING BUTTON
 Lamp is "green" when this feature is activated.

TEMPERATURE BUTTONS
 "∨" adjust temp. to lower setting.
 "∧" adjust temp. to a higher setting.

ON/OFF BUTTON
 Easy operation
 One touch ignition

All buttons beep when operated.

Operating Information

Turning the heater ON

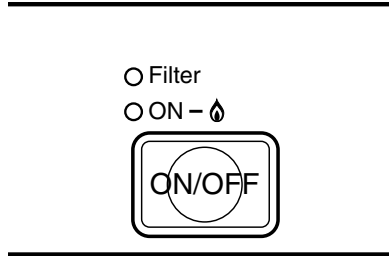

When you press the ON/OFF button, the LED display will illuminate, the spark will ignite the main burner and the combustion fan will begin to run.

This heater has an automatic ignition system. When the main burner has lit, the combustion lamp will glow red, and the spark will stop.

If ignition does not occur after 15 seconds, the appliance will automatically turn off and fault code 11 will be displayed on the control panel. This may occur when using the appliance for the first time or if it has not been used for a while. Try operating the appliance again.

There may be a smell of burning dust or oil the first time the heater is lit or when the heater has been out of operation for a long time.

The appliance may make noises after ignition or when it is turned off. This is normal and is due to the thermal expansion or contraction of its components.

Turning the heater OFF

Press the ON/OFF button. Do not turn off by unplugging at the power outlet.



The fan will continue to run for a short time to prevent the internal components from overheating.

Adjusting the Temperature

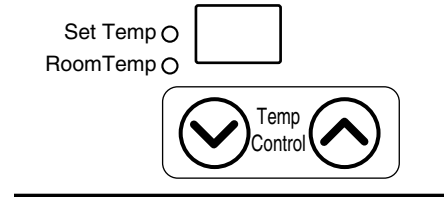

The temperature setting and the room temperature are indicated by the L.E.D. display on the control panel. When the appliance is turned on the temperature setting will be displayed for 10 seconds. The display will then show the room temperature. The default temperature setting is 72° F.

To change the temperature setting press one of the temperature control buttons once. The "Set Temp" should light up and the display will show the current temperature setting. Continue to press the control buttons until the desired temperature setting is reached. After 10 seconds the display will return to showing the room temperature.

The thermostat automatically modulates the burner and the fan to maintain the temperature setting.

The temperature settings available are:

- LO - burner is on minimum combustion
- 60° F - 80° F in two degree increments
- HI - burner is on maximum combustion

Economy Mode

Pressing the Economy button will cause the appliance to go into Economy Mode and the green lamp will glow. This results in the temperature setting being reduced by 2° F, 30 minutes after the room temperature has reached the temperature setting. After another 30 minutes the temperature setting is reduced another 2° F. This could result in the temperature setting being reduced by a maximum of 4° F. The intent of this mode is to save energy.

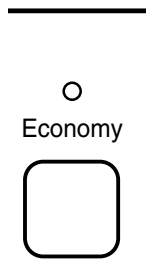

Operating Information

Function Lock

This feature locks the buttons to prevent unintended operation.

Press the Function Lock button to activate and the lamp will glow. Pressing and holding the Function Lock button for two seconds will disengage the function lock.

If the Function Lock is engaged while the unit is operating, all buttons will be disabled except for the ON/OFF button.

If the Function Lock is engaged while the unit is off, then all buttons will be disabled.

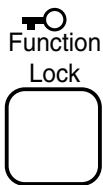

Adding Water to the Humidifier

CAUTION Do not remove the bottom trim panel or the humidifier tray while warm air is flowing.

Warm air is humidified when it passes over the water in the tray.

Remove the bottom trim panel below the louvers by pulling on both sides. Pull the tray out and fill with water. Push the tray back in and attach the bottom trim panel.

During operation a small amount of condensation is produced in the flue system and drains into the humidifier tray.

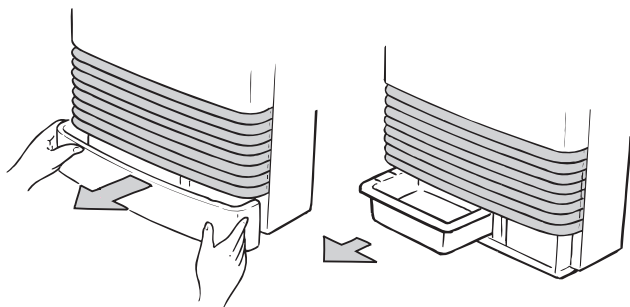

Adjusting Air Flow Direction

CAUTION Do not adjust the air flow louvers while warm air is flowing.

The vertical louvers may be adjusted to move the air flow more to the right or to the left.

Use a screw driver or similar object to bend each louver to the desired position.

Do not bend repeatedly (no more than 5 times) or else the louver will break.

The horizontal louver (which determines the vertical air flow direction) is fixed and cannot be adjusted.

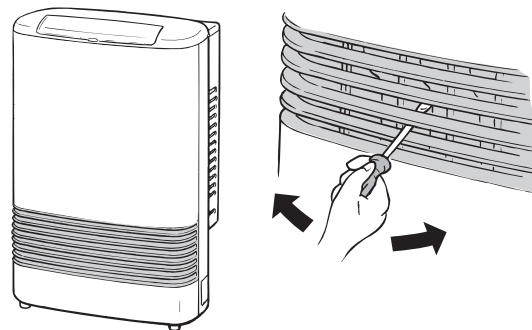

Sensible Temperature Control

The sensible temperature control feature allows comfortable heating which matches the conditions in the room.

Based on the information collected by the room temperature thermistor when the heating starts, the heating capacity is automatically adjusted to achieve a comfortable heating effect and to reach the temperature setting quickly.

Care and Maintenance

Maintenance

CAUTION

Label all wires prior to disconnection when servicing controls. Wiring errors can cause improper and dangerous operation.

Repairs should be performed by a qualified service technician. The appliance should be inspected annually by a qualified service technician. More frequent cleaning may be required due to excessive lint from carpeting, bedding material, etc. It is imperative that control compartments, burners, and circulating air passage ways of the appliance be kept clean.

Any screen or guard removed for servicing the appliance must be replaced prior to operating the appliance. Clean as follows:

1. Turn heat off. Allow to cool for one hour.
2. Remove the front panel by removing six screws.
3. Use pressurized air to remove dust from the main burner, heat exchanger, and fan blades.
4. Use soft dry cloth to wipe cabinet.

Do not use wet cloth or spray cleaners on the burner.

The flue should be inspected annually for blockages or damage.

Motors are permanently lubricated and do not need periodic lubrication. Keep fan and motor free of dust and dirt by cleaning annually.

Verify proper operation after servicing.

Care of Exterior

Dampen soft cloth with warm water. Wring water out well and wipe the unit.

Do not use volatile substances such as benzene or thinners. They cause fading of the paint and deformation of the resin.

Snow Accumulation

Keep the area around flue terminal free of snow and ice. The appliance will not function properly if the intake air or exhaust is impeded by obstructions.

Filters

Dirty filters reduce the air flow and the appliance's ability to produce heat. The filters should be cleaned frequently during the heating season. If the filters become blocked the filter indicator lamp will flash red. Eventually the appliance will turn off and display fault code 14 on the control panel display.

To clean the filters, the appliance should be OFF and cool. Remove the filter and clean it using a soft dry cloth or vacuum. If the filter is greasy wash with warm soapy water, rinse, and dry completely.

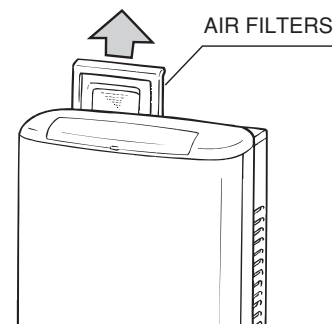

Visual Inspection of Flame

Check that the burner flames are operating normally. The flame can be seen through the circular window through the louvers.

When operating normally the burner flame should appear as long, clear, blue, stable, streaks. Yellow flames or an orange color is abnormal and maintenance is required.

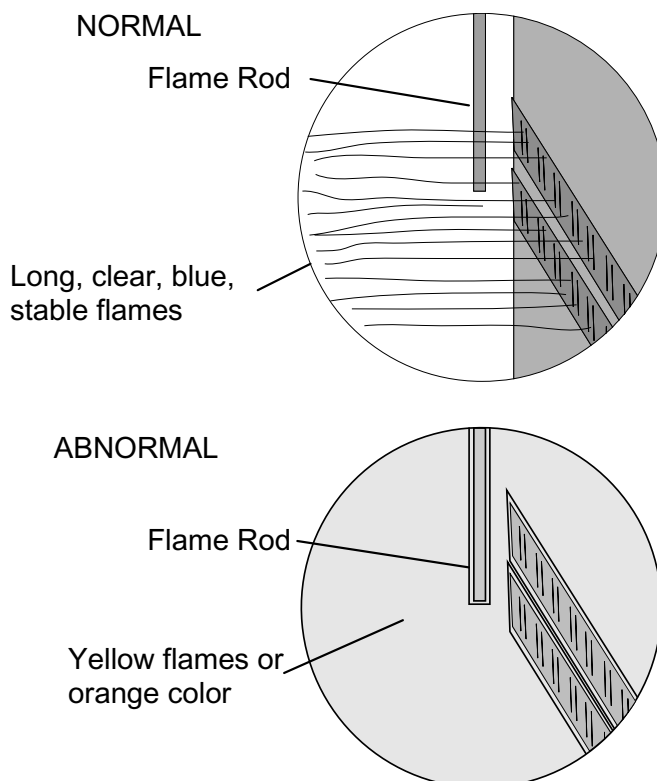

Before Making a Service Call

Before making a service call please check the following:

■ At Ignition:

Heater does not operate.	➔	Is the heater plugged in? Have the fuses or breaker blown at the switch board? Is there a power failure? Is the air filter blocked? Is anything blocking the outlet for the hot air? Is the flue blocked?
Warm air does not flow when the burner lights.	➔	The fan is started automatically after a short delay. This is to allow the heat exchanger to warm up, helping to avoid cold draughts.
Smoke or strange smells are produced on the first trial light up after installation.	➔	This is caused by grease or oil and dust on the heat exchanger and will stop after a short time.
Sharp clicking noises at ignition, or when unit cuts down on the thermostat, or goes out.	➔	This is simply expansion noise from the heat exchanger.

■ During Combustion:

Clunking noise when the thermostat operates.	➔	This is the sound of the solenoid gas valves opening and closing.
Unit is not heating room.	➔	Is the air filter blocked? Is the set temperature high enough? Is the warm air outlet blocked by anything? Are the doors and windows of the room closed? Was the appliance correctly sized for the space?
Air filter is blocked or the louvers are blocked or obstructed.	➔	Allow heater to cool, clean air filter, operate again.
Heater will not re-ignite after overheating.	➔	Even after unit has cooled down, the heater does not ignite again. Repair is necessary. Contact your local agent or Rinnai for a Service call.

■ When the unit is turned off.

Convection fan continues to run after turning OFF.	➔	This is to remove the residual heat from the heat exchanger. The fan will stop when the heater cools down.
--	---	--

■ Other Points:

Steam is discharged from the flue terminal.	➔	High efficiency appliances tend to discharge water vapor on cold days. This is normal.
Unit cuts off without apparent reason.	➔	Check whether filters are blocked. Dirty filters will cause the heater to overheat.
Power Failure.	➔	Switch OFF, then ON again when power is restored to re-set controls.

Troubleshooting

Cause \ Problem	Problem							Remedy
	No ON indicator	Burner doesn't ignite	Unusual combustion	Combustion stops during operation	Smell of gas	Noisy ignition	Takes too long to warm the room	
Not Plugged In	●	●						Plug In
Power Failure	●	●		●				Push On/Off button to attempt restart after power is restored.
(Initial Installation) Air In Gas Pipe		●						Purge air (Installer)
Gas Filter Blocked		●	●				●	Service Call
Miss Ignition	●	●						Service Call
Flue terminal obstructed			●	●		●		Clear obstruction
Flue manifold not connected						●		Service Call
Louver obstructed				●			●	Clear obstruction
Air filter blocked				●			●	Clean filter
Gas Escape					●			Service Call
Function Lock Set		●						Cancel Function Lock
Gas turned off at meter, tank, or valve.	●	●						Turn gas on

Fault Codes

If there is a malfunction the appliance may shut down as a safety precaution and display a fault code to assist in diagnosing the problem. The fault code will flash in the display on the control panel. When making a service call, this code will assist with diagnosing the fault.

You may be able to clear the fault code by turning the heater off and then on again. If the fault code remains or returns on the next operation, contact Rinnai or your nearest service agent and arrange for a service call.

CODE DISPLAYED	FAULT	REMEDY
11	Ignition failure	Check gas is turned ON. Service call if repeated.
12	Flame failure	Check gas is turned ON. Service call if repeated.
14	Overheat	Clean filter Service call if repeated. [1]
16	Room overheat	Lower room temperature to less than 104°F(40°C).
31	Room Temperature Sensor faulty	Service call.
32		
33	Overheat Temperature Sensor faulty	Service call.
34		
53	Sparker failure	Service call.
61	Combustion fan failure	Service call.
70	Faulty ON/OFF switch	Service call.
71	Faulty solenoids	Service call.
72	Faulty Flame Rod	Service call.
73	Communication Error	Turn heater OFF, then ON again.
49	Sensor breakdown	Service Call.
99	Flue block	Check around flue terminal [2]

[1] Remove any obstructions. The flue needs to be kept clear to expel exhaust gases. If the appliance fails to operate contact a qualified service agency.

[2] If the fusible link needs replacement, it must be done by a qualified service agency. In addition, the cause of the overheat needs to be determined. The fusible link is a one use safety device that breaks to shut off the appliance.

Installation Instructions

General Instructions

WARNING

Do not use substitute materials.

Use only parts certified with the appliance.

- A qualified service technician should install the appliance and inspect it before use.
- If you move, check the gas type in your new area. The local gas authority will be able to advise on local regulations.
- The installation must conform with local codes or, in the absence of local codes, with the *National Fuel Gas Code, ANSI Z223.1/NFPA 54*, or the *Natural Gas and Propane Installation Code, CSA B149.1*.
- A manufactured home (USA only) or mobile home OEM installation must conform with the *Manufactured Home Construction and Safety Standard, Title 24 CFR, Part 3280*, or, when such a standard is not applicable, the standard for *Manufactured Home Installations, ANSI/ NCSBCS A225.1*, or the standard for *Gas Equipped Recreational Vehicles and Mobile Housing, CSA Z240.4*.
- The appliance, when installed, must be electrically grounded in accordance with local codes or, in the absence of local codes, with the *National Electrical Code, ANSI/NFPA 70*, or the *Canadian Electrical Code, CSA C22.1*.
- Appliance input ratings are based on sea level operation and need not be changed for operation up to 2000 ft (609.9 m) elevation. For operation at elevations above 2000 ft (609.9), refer to the Conversion Manual.
- The appliance and its appliance main gas valve must be disconnected from the gas supply piping system during any pressure testing of that system at test pressures in excess of 1/2 psi (3.5 kPa).
- The appliance must be isolated from the gas supply piping system by closing its equipment shutoff valve during any pressure testing of the gas supply piping system at test pressures equal to or less than 1/2 psi (3.5 kPa).
- If the flooring is carpet, tile, or other combustible material other than wood, then the appliance must be installed on a metal or wood panel extending the full width and depth of the appliance.
- This appliance discharges a large volume of warm air next to the floor. Any particles in the air such as cigarette smoke could cause discoloration in carpet. The warm air flow could discolor nylon carpets containing dyes or vinyl surfaces. To prevent discoloration of the floor covering a mat may be placed under the appliance which extends about 30 inches (750 mm) in front of it.
- This appliance is not designed to be built in.
- This appliance is only for use with the type of gas indicated on the rating plate. This appliance is not convertible for use with other gases unless a certified kit is used. If a conversion of the unit is needed, conversions must be performed by a qualified service provider at the owner's expense.
- This appliance must not be connected to a chimney flue serving a separate solid-fuel burning appliance.
- Rinnai suggests that a dedicated electrical circuit with a 120VAC, 60 hz, 10 amp power source be used.
- Two 1/8 in test plugs are provided for testing of manifold differential pressure. They are located on the modulating gas valve and on the burner manifold.
- The appliance should be correctly sized for the space it required to heat.
- Follow the installations instructions and those in Care and Maintenance for adequate combustion and ventilation air.
- The flow of combustion and ventilation air shall not be obstructed.
- Clearances to access the appliance during servicing are 2 inches (50 mm) from the sides, 40 inches (1 m) from the front, and 9 inches (225 mm) from the top.

Gas Connection

- The gas supply line shall be gas tight, sized and so installed as to provide a supply of a gas sufficient to meet the maximum demand of the heater without loss of pressure.
- A shut off valve and appliance connector valve should be installed in the upstream of the gas line to permit servicing.
- Flexible pipe and any appliance connector valve used for gas piping shall be types approved by nationally recognized agencies.
- Any compound used on the threaded joint of the gas piping shall be a type which resists the action of liquefied petroleum gas.
- Check the gas supply pressure immediately upstream at a location provided by the gas company. Supplied gas pressure must be within the limits shown in the Specifications section.
- After completion of gas pipe connections all joints including the heater must be checked for gas tightness by means of leak detector solution, soap and water, or an equivalent nonflammable solution, as applicable. (Since some leak test solutions, including soap and water, may cause corrosion or stress cracking,

the piping shall be rinsed with water after testing, unless it has been determined that the leak test solution is non-corrosive.)

- Refer to an approved pipe sizing chart if in doubt about the size of the gas line.
- Install manual gas cut-off valve so that it can be accessed for easy operation. Do not conceal manual cut-off valve behind back spacer.

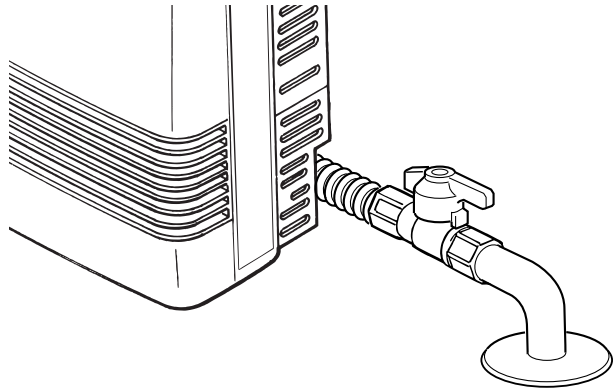

Clearances to Combustibles



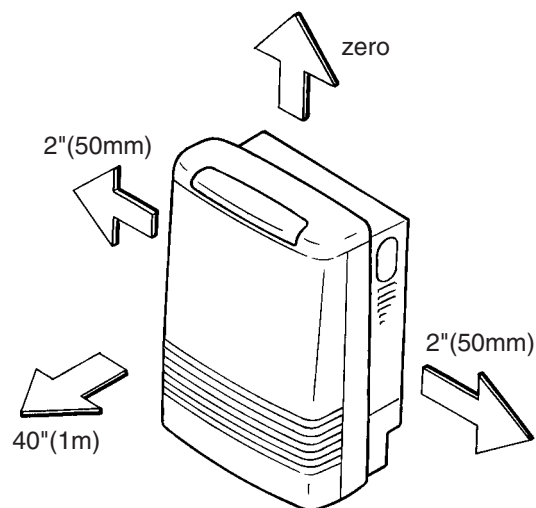







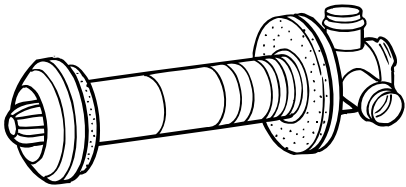

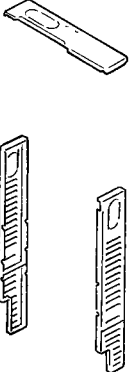
When determining where to install the appliance the clearances to combustibles shown in the figure must be followed. Also refer to the Safety Behaviors and Practices section. The clearance to combustibles from the top is zero.

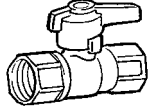

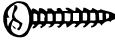
Installation Parts

The following items are included with the appliance.

- Owner s Operation and Installation Manual
- Conversion Manual
- Conversion Kit
- “A” Vent Kit
- Manual valve set, backspacers, screws, pipe stoppers, and hardware listed below

 <p>Flue Manifold1</p>		 <p>Spare rubber seal1 (‘A’ Flue units only)</p> <p>(For weatherboard installations)</p>			
Back Spacer Set		1	Spacer Bracket		1
			Pipe Stopper		1
			Manual Valve Set		1
			Screw	 (For Clamp)	2
Insulation Clip		1	Screw	 (For Wall Bracket and Flue manifold)	5
Plastic tie for air inlet		1	Screw	 (For Back Spacer)	10
Clamp		2	Screw	 (For Flue Manifold)	3
Wall Bracket		1	Owner’s Manual Conversion Manual		1

Drilling Flue Hole

Check for water and gas pipes as well as electric cables. Drill the flue hole using a 3 1/8 inch (80 mm) drill. The center of the hole must be located exactly at the specified point.

See diagram. For weatherboard walls, drill through the center of the weatherboard from the outside first and then through the plasterboard. A template is provided.

A maximum of one elbow (FOT-158) may be used to raise the flue manifold's position by 6 in (154 mm) relative to the appliance. Rotate the flue elbow 90° to a vertical position and attach the FOT-158 so that it opens toward the center of the appliance. If the FOT-158 is used then do not use the template. The center of the wall opening will be 16 1/2 in (418.5 mm) above the base of the appliance.

Dimensions

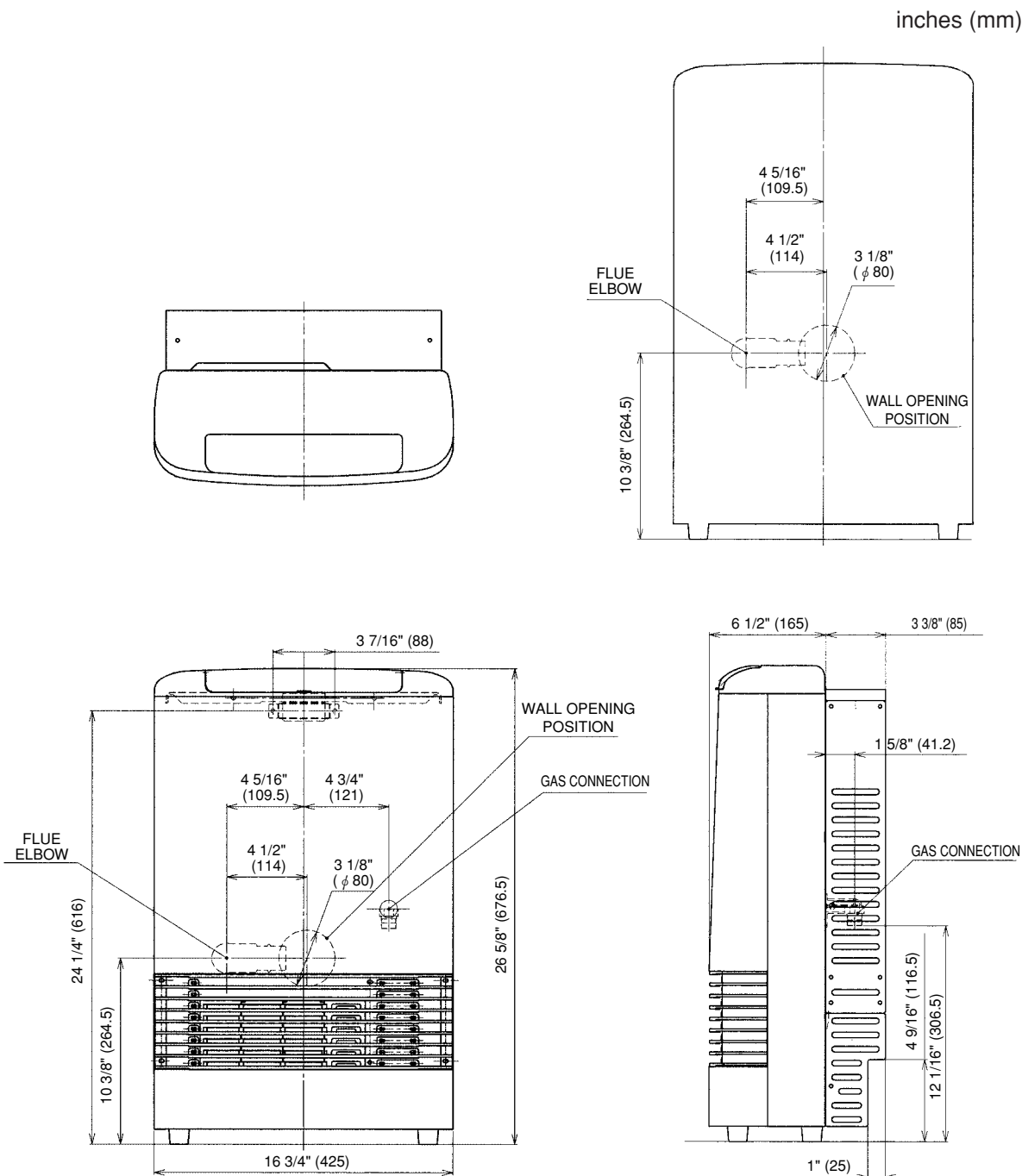

Flue Terminal Clearances

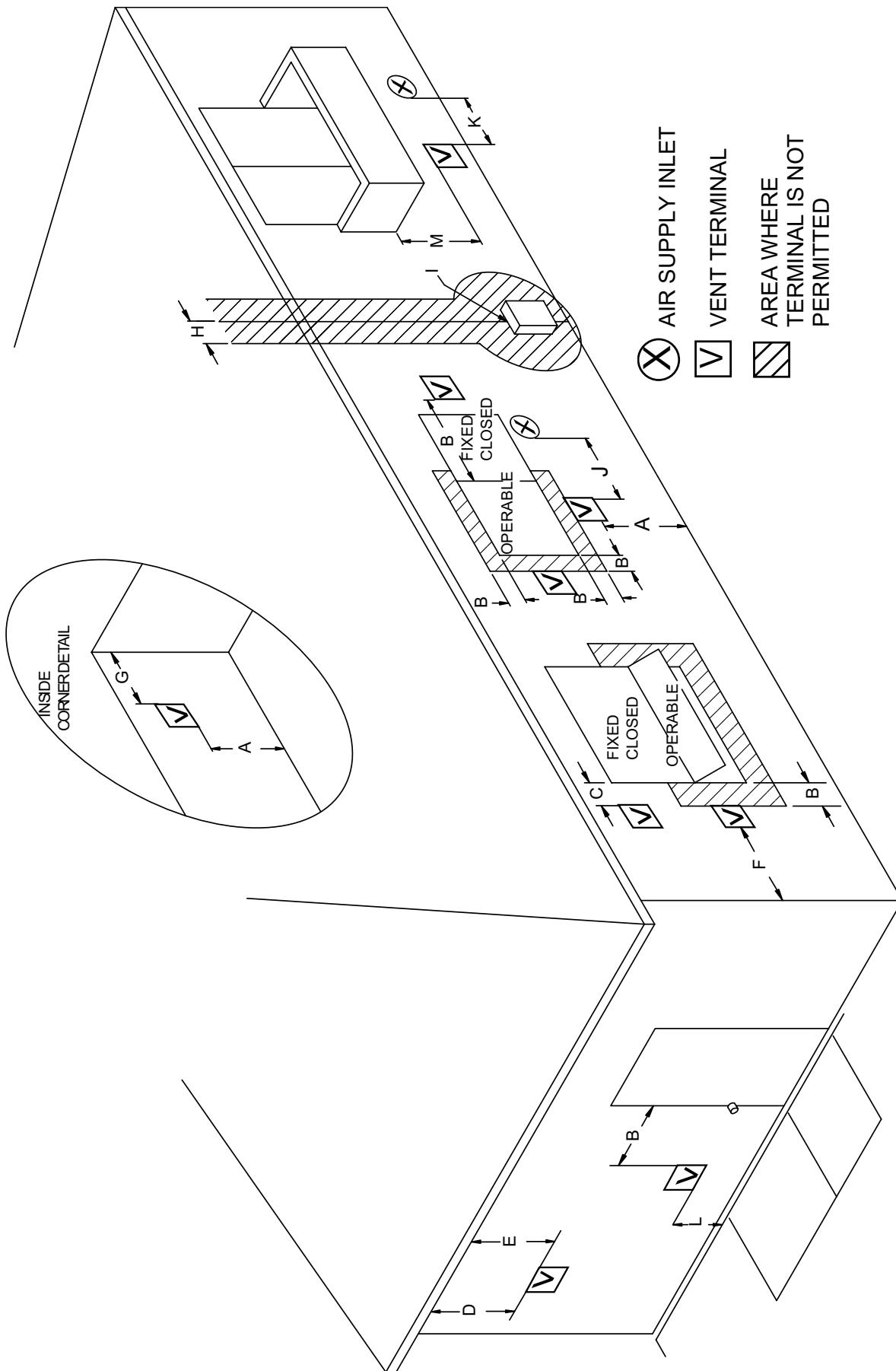

Flue Terminal Clearances

Ref	Description	Canadian Installations	US Installations
A	Clearance above grade, veranda, porch, deck, or balcony	12 inches (30 cm)	12 inches (30 cm)
B	Clearance to window or door that may be opened	6 inches (15 cm)	6 inches (15 cm)
C	Clearance to permanently closed window	*	*
D	Vertical clearance to ventilated soffit, located above the terminal within a horizontal distance of 2 feet (61 cm) from the center line of the terminal	*	*
E	Clearance to unventilated soffit	*	*
F	Clearance to outside corner	*	*
G	Clearance to inside corner	20 inches (50 cm)	20 inches (50 cm)
H	Clearance to each side of center line extended above meter/regulator assembly	3 feet (91 cm) within a height 15 feet (4.5 m) above the meter/regulator assembly	*
I	Clearance to service regulator vent outlet	3 feet (91 cm)	*
J	Clearance to nonmechanical air supply inlet to building or the combustion air inlet to any other appliance	6 inches (15 cm)	6 inches (15 cm)
K	Clearance to a mechanical air supply inlet	6 feet (1.83 m)	3 feet (91 cm) above if within 10 feet (3 m) horizontally
L	Clearance above paved sidewalk or paved driveway located on public property	7 feet (2.13 m) ^①	*
M	Clearance under veranda, porch, deck, or balcony	12 inches (30 cm) to non-flammables ^② 24 inches (60 cm) to flammables ^②	12 inches (30 cm) to non-flammables ^② 24 inches (60 cm) to flammables ^②

① A vent shall not terminate directly above a sidewalk or paved driveway that is located between two single family dwellings and serves both dwellings.
 ② Permitted only if veranda, porch, deck, or balcony is fully open on a minimum of two sides beneath the floor.

* For clearances not specified in ANS/ Z223.1/NFPA 54 or CSA B149.1, clearances are in accordance with local installation codes and the requirements of the gas supplier.

Clearance to opposite wall is 24 inches (60 cm) for Canada and US.

Flue Manifold Installation

- The flue manifold must exhaust to the outside. Do not exhaust into other rooms.
- The flue is not designed to be positioned under floors or below the heater.
- This appliance can only be used with one of the five types of Rinnai flue kits. The flue kits and their dimensions are listed in the Specifications section.
- Refer to the Flue Terminal Clearances section.

1. Disassemble the flue manifold

The flue consists of 3 parts:

- sleeve
- inside connection
- outside terminal

Disassemble the flue manifold by first pulling out the inside connection. To remove the outer terminal pull and release the two internal ties and then pull out the outer terminal.

Clearance to combustibles for the sleeve and flanges is zero inches.

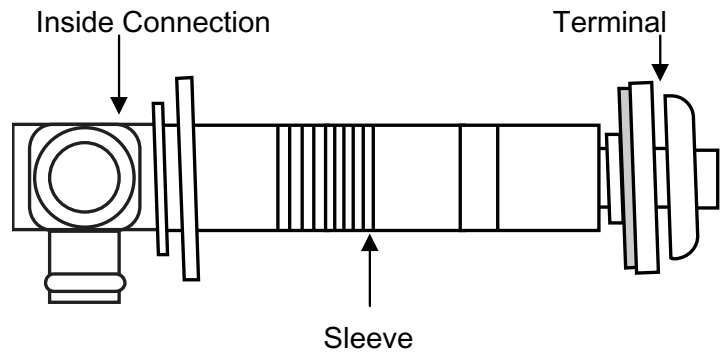

2. Adjust the sleeve length

Measure wall thickness through previously drilled 3 1/8 inch (80 mm) hole.

The end of the sleeve should protrude 3/16 - 3/8 inch (5-10 mm) from the outside wall.

The sleeve is threaded for adjustment. Adjust the sleeve length to wall thickness plus 3/16 - 3/8 inch (5-10 mm).

NOTE: Do not extend beyond the red line.

For other than the “S” type flue manifold, if a shorter length is necessary an extension can be removed. Cut the plastic and remove the extension.

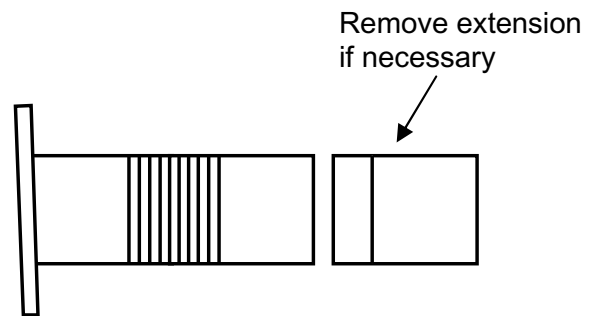

3. Attach the sleeve

Attach to the inside wall using 3 screws arranging the flange so that the marking “TOP” is at the top.

The flange is offset 2° to allow the condensate drain to the outside.

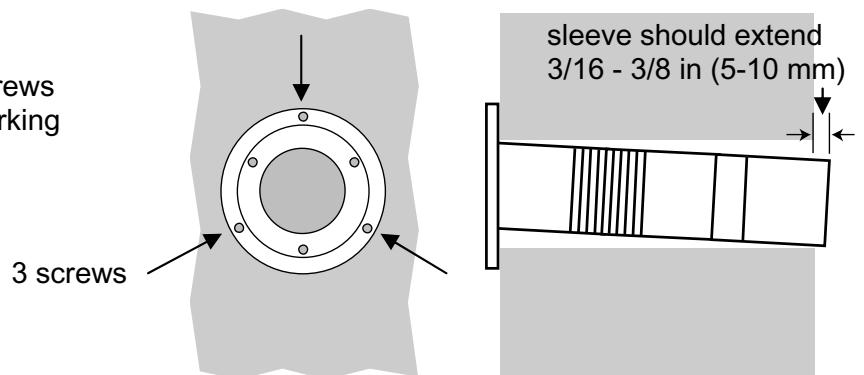

Flue Manifold Installation

4. Install the Terminal

Check that the terminal seal is in place. For weatherboard walls, add the second seal next to the terminal seal to compensate for weather board angle.

From the outside insert the terminal into the sleeve with the marking "TOP" at the top. The left hand side locking tie should be marked "LEFT".

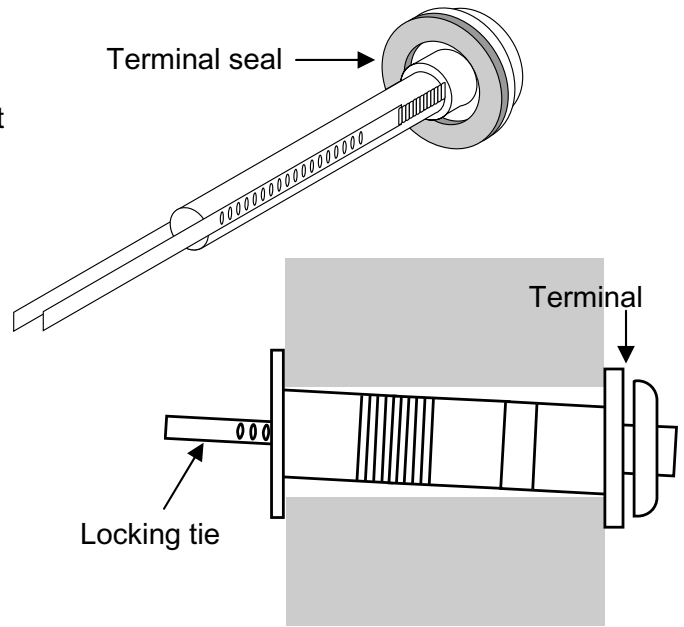

6. Lock the ties

Pulling hard on the left and right hand ties, clip the ties over the notches inside the sleeve. You should be able to pull the ties 2 or 3 notches past the starting point. Cut the ties, leaving about 3/4 inch (20 mm) past the notch. Bend the ties back into the sleeve and parallel to the wall.

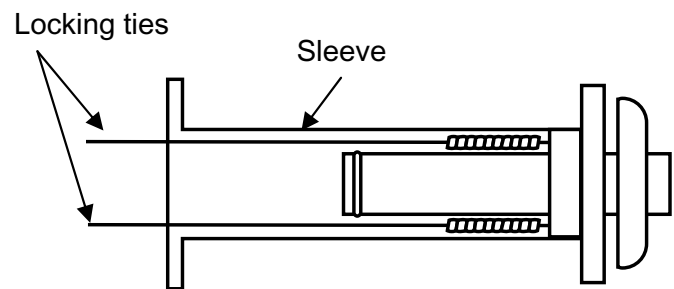

7. Insert Inside Connection Assembly

Push the assemble into the terminal tube, ensuring that the seal is in place on the inner tube.

Attach the inside connection with 3 screws. The inner connection can still be turned to install the screws.

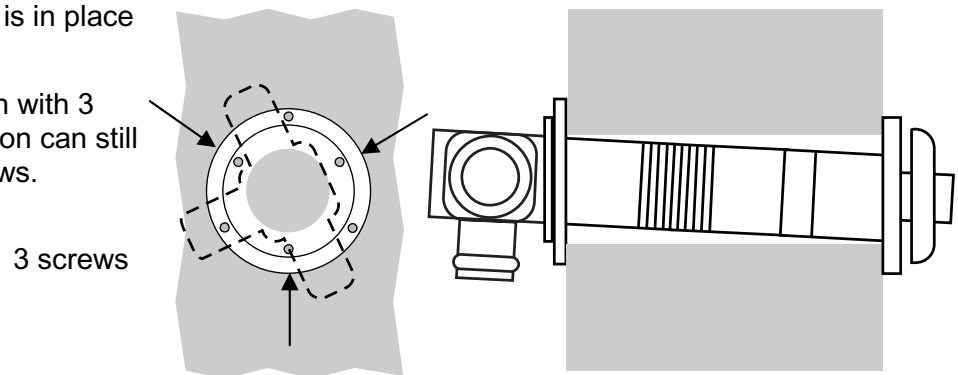

Connecting the Appliance

1. Attach the air inlet hose to the flue manifold on either inlet position "a" or "b".

The unused inlet is plugged with the rubber cap supplied on the manifold.

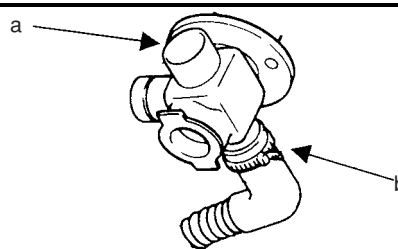

2. Connect the flue elbow to the manifold while moving the appliance into position.

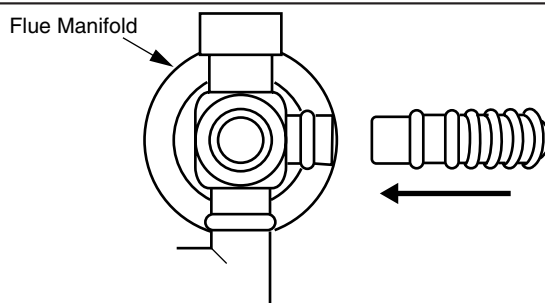

3. Fit the pipe stopper over the connection between the flue elbow and the manifold. Engage the hook and rotate it until it snaps against the body of the clamp.

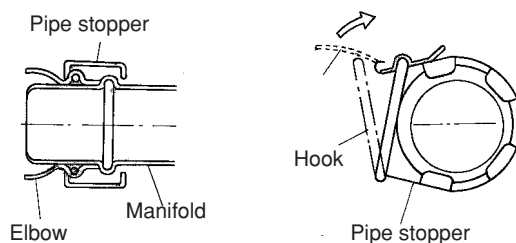

4. Slide the insulation sleeve up to the flue manifold and slip the securing clip over the sleeve as shown.

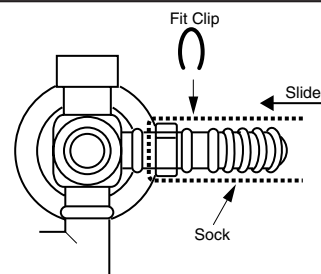

5. Install the bracket on the rear of the top spacer by tightening 2 screws.

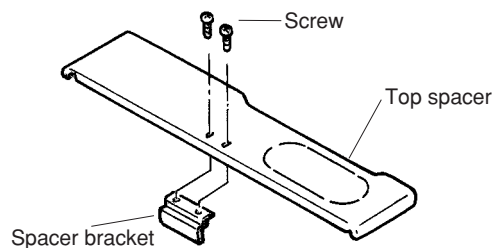

6. Install the wall bracket with two screws. Install the top spacer by clipping the spacer into the wall brackets and attaching it to the heater with 2 screws.

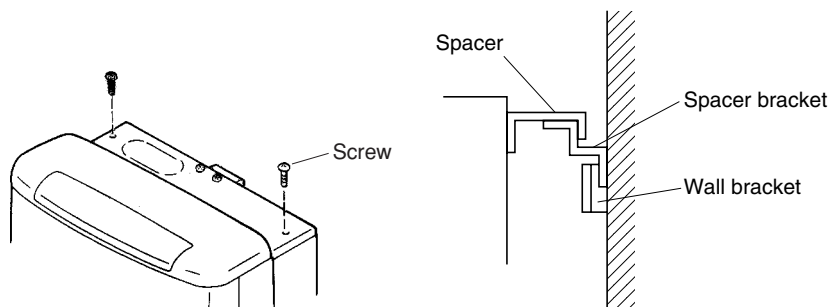
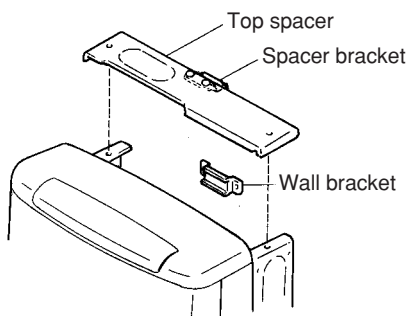

Operating Instructions

FOR YOUR SAFETY READ BEFORE OPERATING





WARNING

If you do not follow these instructions exactly, a fire or explosion may result causing property damage, personal injury or loss of life.

- A. This appliance does not have a pilot. It is equipped with an ignition device which automatically lights the burner. Do not try to light the burner by hand.
- B. **BEFORE OPERATING** smell all around the appliance area for gas. Be sure to smell next to the floor because some gas is heavier than air and will settle on the floor.
- WHAT TO DO IF YOU SMELL GAS
- Do not try to light any appliance.
 - Do not touch any electric switch; do not use any phone in your building.
 - Immediately call your gas supplier from a neighbor's phone. Follow the gas supplier's instructions.
- If you cannot reach your gas supplier, call the fire department.
- C. Use only your hand to push in or turn the gas control knob. Never use tools. If the knob will not push in or turn by hand, don't try to repair it, call a qualified service technician. Force or attempted repair may result in a fire or explosion.
- D. Do not use this appliance if any part has been under water. Immediately call a qualified service technician to inspect the appliance and to replace any part of the control system and any gas control which has been under water.

OPERATING INSTRUCTIONS

1. **STOP!** Read the safety information above.
2. Set the thermostat to lowest setting.
3. Turn off all electric power to the appliance using the ON/OFF button.
4. This appliance is equipped with an ignition device which automatically lights the burner. Do not try to light the burner by hand.
5. Locate the manual gas valve on the side of the heater. Turn the manual valve clockwise to the full OFF position. 
6. Wait five (5) minutes to clear out any gas. Then smell for gas, including near the floor. If you smell gas, STOP! Follow "B" in the safety information above. If you don't smell gas, go to the next step.
7. Turn the manual gas valve counterclockwise to the full ON position. 
8. Turn on all electric power to the appliance using the ON/OFF button.
9. Set the thermostat to desired setting.
10. Combustion indicator glows red when the burner is lit and flashes when the burner fails to ignite. If the appliance will not operate, follow the instructions "To Turn Off Gas To Appliance" and call your service technician or gas supplier. See manual for additional information.

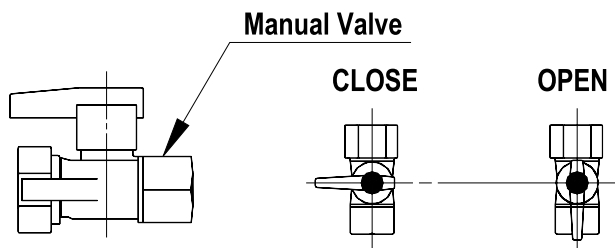

TO TURN OFF GAS TO APPLIANCE

1. Set the thermostat to lowest setting.
2. Turn off all electric power to the appliance using the ON/OFF button.
3. Locate the manual gas valve on the side of the heater. Turn the manual valve clockwise to the full OFF position. 

NOTE: The fan will continue to operate until the appliance is cool. Do not turn the appliance off by unplugging it from the wall. Keep burner and control compartment clean. See installation and operating instructions.

Cut-Away Diagram

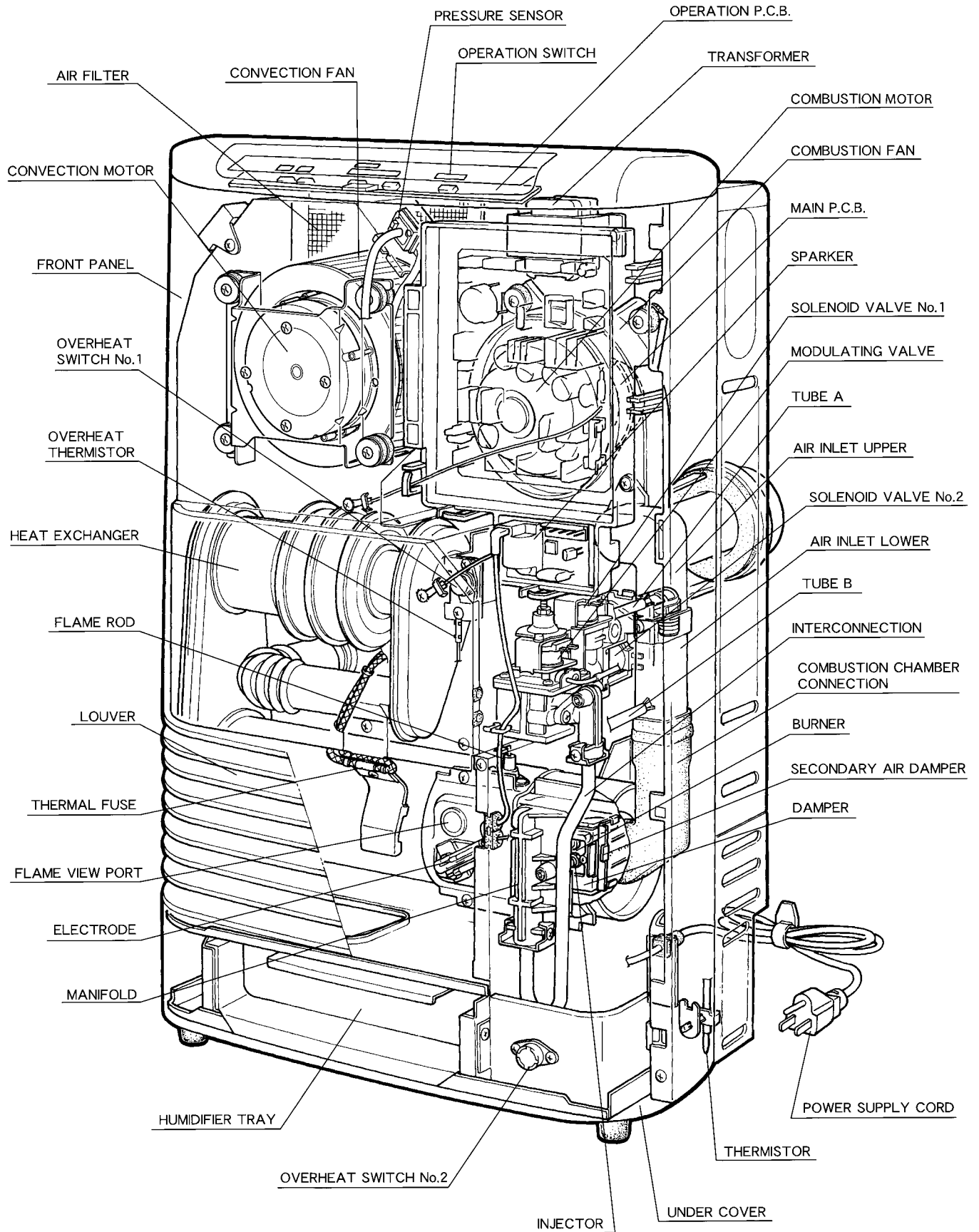

Ladder Diagram

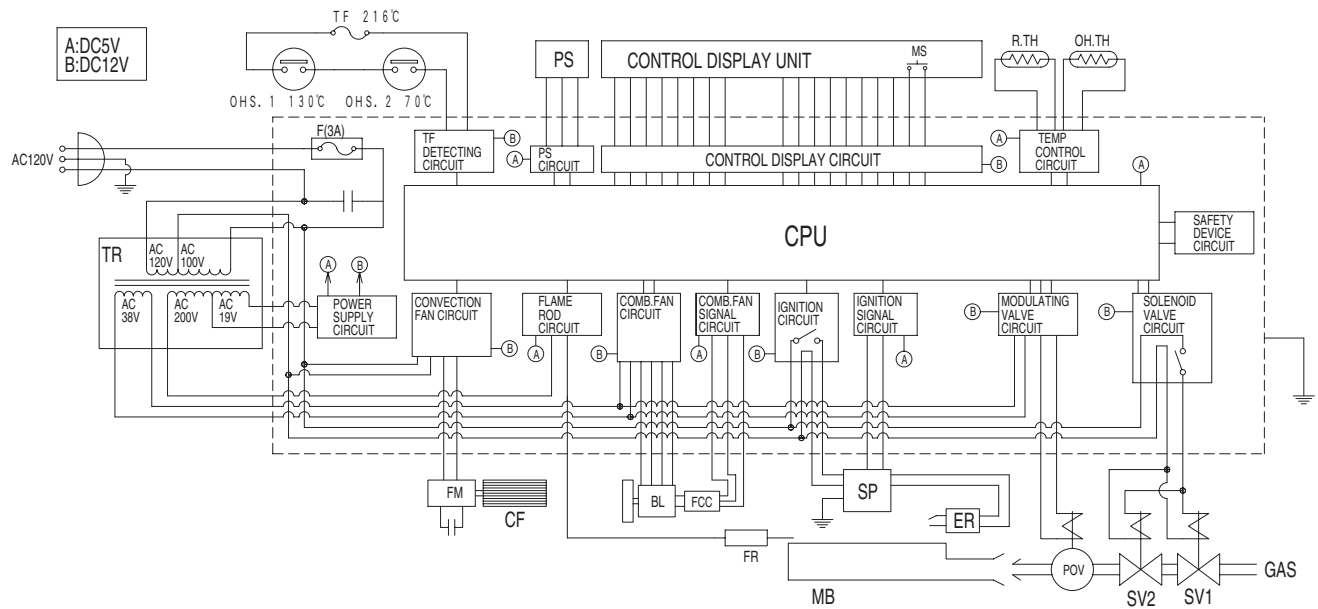

MARK	PARTS NAME
MS	MAIN SWITCH
R.TH	THERMISTOR
TF	THERMAL FUSE
F	FUSE
ER	ELECTRODE
POV	MODULATING SOLENOID VALVE
TR	TRANSFORMER
FR	FLAME ROD
CF	CONVECTION FAN
FM	CONVECTION FAN MOTOR
SP	SPARKER
OH.TH	OVER HEAT THERMISTOR
SV1~2	SOLENOID VALVE 1~2
BL	COMBUSTION FAN MOTOR
FCC	FAN CONTROL CIRCUIT
CPU	CENTRAL PROCESSING UNIT
MB	MAIN BURNER
PS	PRESSURE SENSOR
OHS. 1~2	OVERHEAT SWITCH 1~2

Flow Diagram

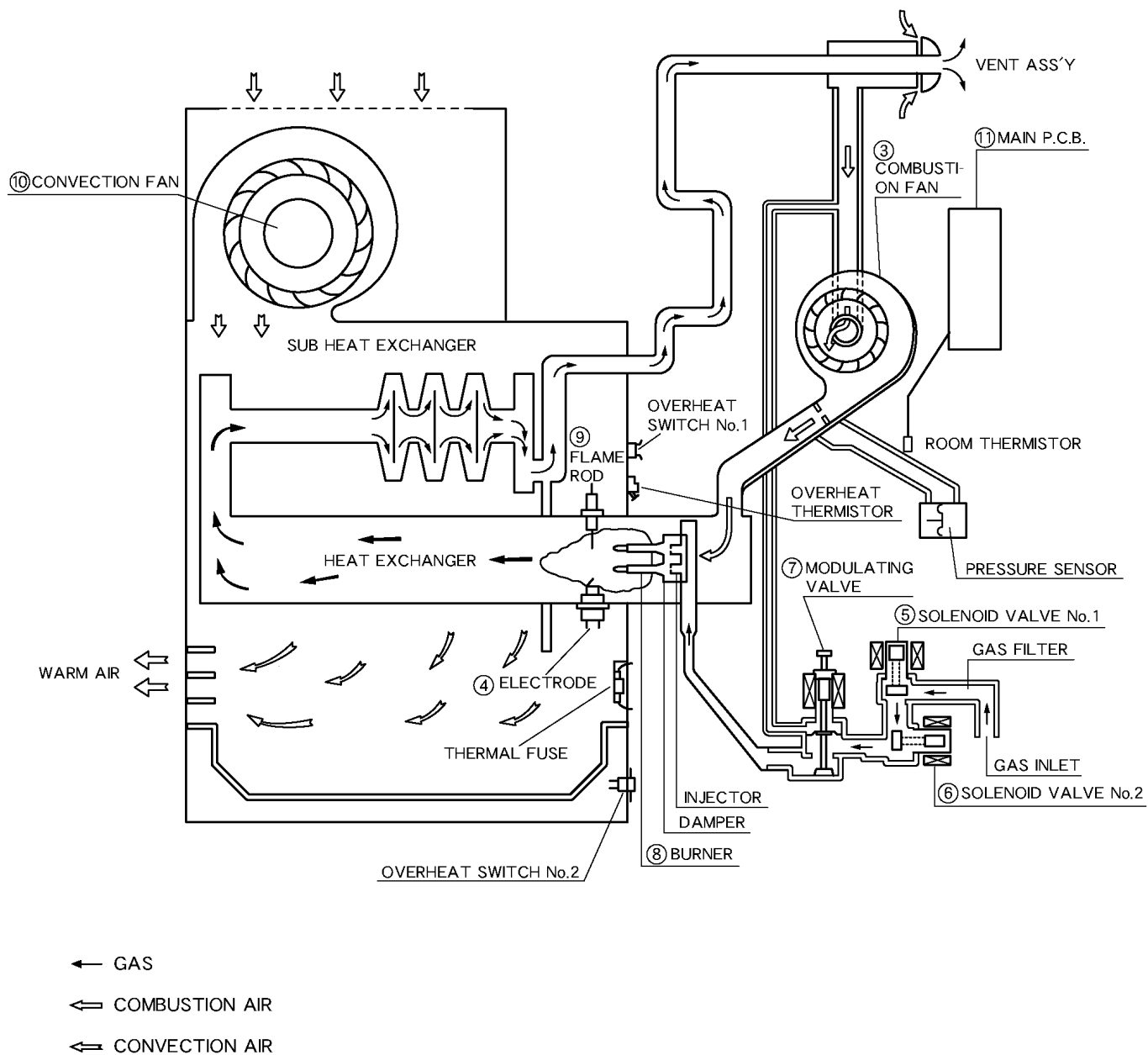

Parts List

For replacement parts call Rinnai at 1-800-621-9419.

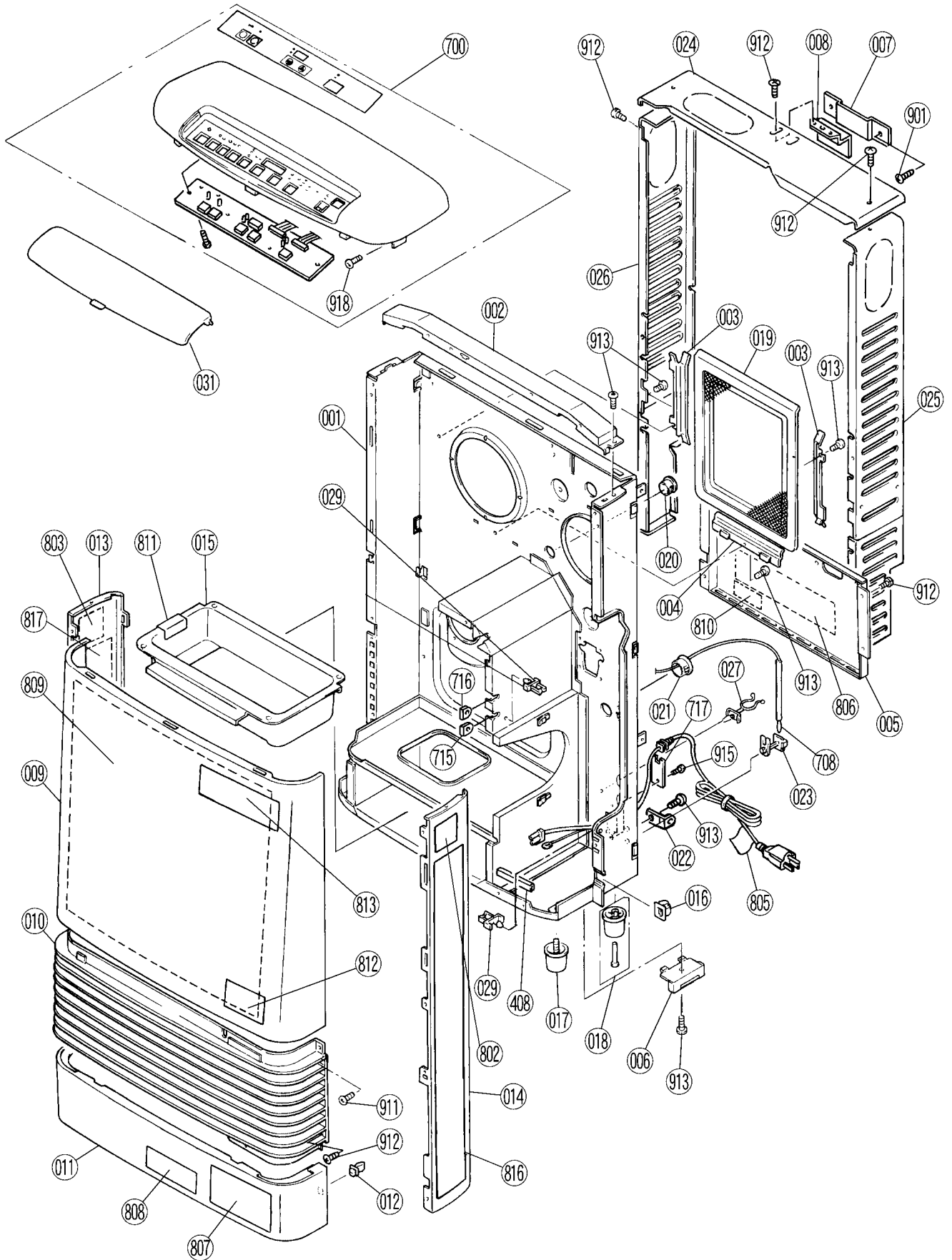

Parts List

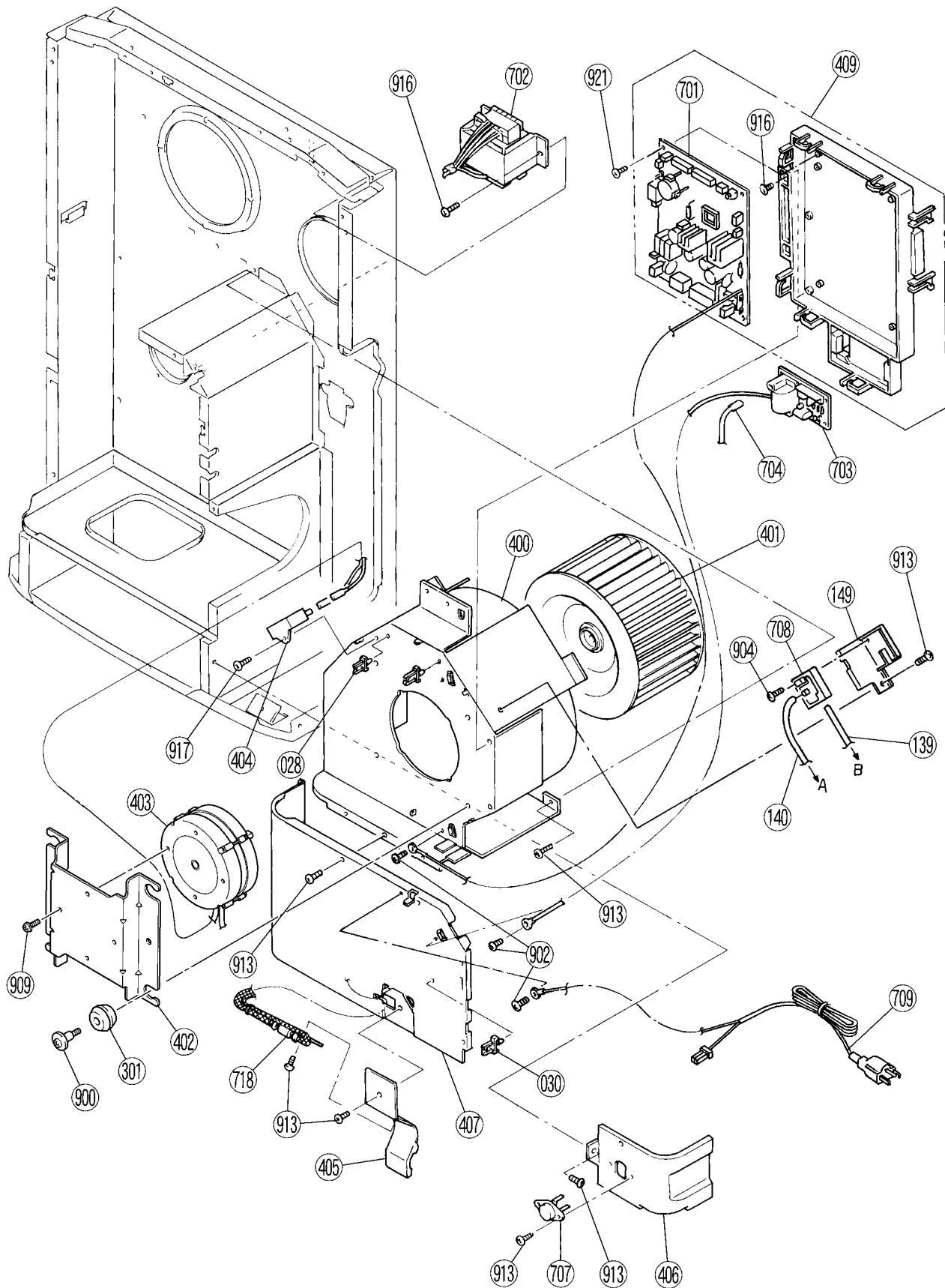

Parts List

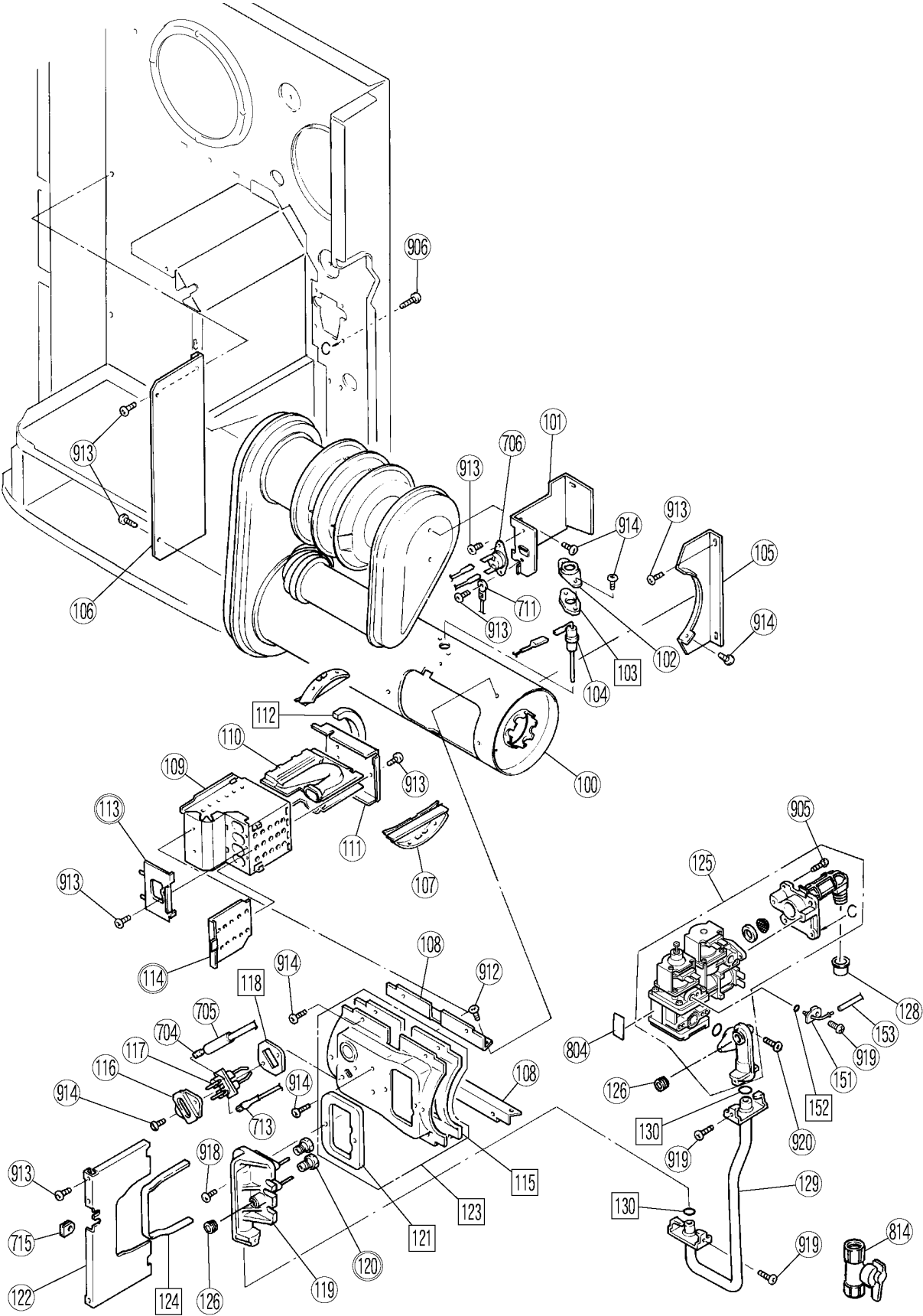

Parts List

No.	PART No.	PART NAME	QTY'
001	201F-2016	REAR PANEL ASS'Y	1
002	308F-316	TOP PLATE SUPPORTER	1
003	556F-313	FILTER BRACKET	2
004	308F-312	FILTER BRACKET	1
005	308F-324-2	HEAT SHIELD PANEL B	1
006	308F-454	BRACKET FIXER	2
007	308F-9077	WALL BRACKET	1
008	RHF300-152	SPACER BRACKET	1
009	308F-401-3	FRONT PANEL	1
010	201F-2028-1	AIR OUTLET	1
011	308F-408-3	UNDER COVER ASS'Y C	1
012	CP-90379	STRIKE	2
013	308F-402-3	SIDE PANEL LEFT C	1
014	308F-403-3	SIDE PANEL RIGHT C	1
015	308F-326	HUMIDIFIER TRAY	1
016	CP-90380	LATCH	2
017	554F-422	FRONT LEG	2
018	554F-417	LEG	2
019	308F-462-3	AIR FILTER ASS'Y C	1
020	CP-90326-2	BUSH	1
021	CP-90326	BUSH	1
022	557F-1012	BACK SPACER BRACKET	2
023	RC-312-628	THERMISTOR HOLDER	1
024	308F-457-3	BACK SPACER TOP	1
025	308F-2050-1	BACK SPACER RIGHT ASS'Y	1
026	308F-2050-2	BACK SPACER LEFT ASS'Y	1
027	CP-90125-2	CABLE CLIP	2
028	CP-90203-1	CLAMP	2
029	CP-90107-25	WIRE CLIP	2
030	CP-90107-4	WIRE CLIP	1
031	308F-520-9	OPERATION COVER	1
100	308F-130-2	HEAT EXCHANGER ASS'Y B	1
101	308F-216	OHS BRACKET	1
102	RHF-250-038	ELECTRODE PLATE	1
103	554F-148	FLAME ROD PACKING	1
104	1001F-104-3	FLAME ROD	1
105	556F-215	COMBUSTION CHAMBER FIXER	1
106	308F-214	HEAT EXCHANGER BRACKET	1
107	556F-135	SEAL PLATE	2
108	556F-131-2	FLANGE B	2
109	308F-205-2	BURNER BOX ASS'Y	1
110	B3A2-4	BURNER ASS'Y	2
111	556F-225-2	BURNER SUPPORTER ASS'Y	1
112	556F-211	BURNER BOX PACKING	1
113	308F-209	PRIMARY DAMPER	1
114	556F-208	SECONDARY AIR DAMPER	1
115	556F-210-2	PACKING B	1
116	554F-114	ELECTRODE MOUNTING PLATE	1
117	556F-510	ELECTRODE	1
118	554F-147	ELECTRODE PACKING	1
119	308F-202-2	MANIFOLD	1
120	AU129-210	INJECTOR	2
121	556F-203-2	MANIFOLD PACKING	1

Parts List

No.	PART No.	PART NAME	QTY
122	308F-318	WARM AIR SEAL PANEL	1
123	556F-224-SP-2	BURNER BOX FITTING PLATE SET B	1
124	554F-421-2	HEAT EXCHANGER PACKING	1
125	PC-120	GAS CONTROL ASS'Y	1
126	AU39-965	BLIND SCREW	2
128	3022-0363	INLET CAP	1
129	308F-221	CONNECTING TUBE	1
130	M10B-1-10	O RING	2
131	308F-2028	AIR INLET UPPER	1
132	201F-2025	AIR INLET LOWER	1
133	308F-2027	AIR INLET PACKING	1
134	308F-612	AIR INLET PACKING	1
135	553F-340-2	AIR INLET B	1
136	RHF300F-79	AIR INLET PACKING	1
137	308F-611	COMBUSTION CHAMBER CONNECTION	1
138	556F-408	CONNECTION PIPE BRACKET	1
139	1004F-2052-1	TUBE A(CLEAR)	1
140	1004F-2052-3	TUBE C(BLACK)	1
141	308F-137	EXHAUST EL BOW ASS'Y	1
142	RHF300-200-e	O RING	1
143	302F-1103-2	COVER	1
144	302F-1206	INSULATION CLIP	1
145	305F-0017	PIPE STOPPER	1
146	RHF300-51-8	FLEXIBLE HOSE	1
147	RHF300-52	INLET ELBOW	1
148	431F-1900	VENT ASS'Y	1
149	308F-2038	SENSOR BRACKET	1
150	CP-90378	CLAMP	2
151	556F-417	BACK PRESSURE PIPE ASS'Y	1
152	M10B-1-4	O RING	1
153	556F-415-2	TUBE B	1
300	201F-2031	COMBUSTION FAN MOTOR ASS'Y	1
301	308F-8273	CUSHION RUBBER	7
302	308F-434	COMBUSTION FAN CASING ASS'Y	1
400	308F-232-2	CONVECTION FAN CASING B	1
401	308F-231	CONVECTION FAN	1
402	201F-2036	MOTOR BASE	1
403	201F-2037	CONVECTION MOTOR ASS'Y	1
404	201F-2037-2	CAPACITOR	1
405	308F-313	TF BRACKET	1
406	308F-325	OHS No.2 BRACKET	1
407	308F-320	HEAT SHIELD PANEL	1
408	CP-90157a-75	EDGING	1
409	308F-2030-2	P.C.B. TOTAL ASS'Y	1
700	308F-2040	TOP PLATE TOTAL ASS'Y	1
701	ED-499	P.C.B. ASS'Y	1
702	ET-258	TRANSFORMER	1
703	EH-161	SPARKER	1
704	308F-2035	HIGH TENSION CORD	1
705	3022-0344	SLEEVE	1
706	ES-01171	OVERHEAT SWITCH	1
707	ES-01189	OVER HEAT SWITCH	1
708	1004F-2051	PRESSURE SENSOR	1

Parts List

No.	PART No.	PART NAME	QTY'
709	CP-90466-3	POWER SUPPLY CORD	1
710	308F-2045	MOTOR LEAD ASS'Y	1
711	308F-2046	THERMISTOR ASS'Y	1
712	431F-1430	FR LEAD ASS'Y	1
713	308F-2047	SV.IG LEAD ASS'Y	1
714	1004F-2053	SENSOR LEAD ASS'Y	1
715	AU131-236-b	CORD PACKING B	4
716	AU131-236-a	CORD PACKING A	1
717	RC-329-1033	POWER SUPPLY CORD BRACKET	1
718	308F-534	TF LEAD ASS'Y	1
800	201F-2050	OWNER'S MANUAL	1
801	201F-2052	CONVERSION MANUAL	1
802	CP-74167-17	RATING PLATE	1
802	CP-74167-18	RATING PLATE	1
803	CP-74168-17	RATING PLATE	1
803	CP-74168-18	RATING PLATE	1
804	CP-72062B-13	SPECIFICATION MARK	1
805	431F-1860	POWER SUPPLY CORD LABEL	1
806	431F-1840	PROPANE STICKER	1
806	431F-1841	NG STICKER	1
807	556F-2065	CAUTION LABEL	1
808	1001F-1656	CAUTION MARK	1
809	308F-2063	OPERATION LABEL	1
810	1001F-1654	EXHAUST CAUTION LABEL B	1
811	550F-1418	WATER LINE LABEL	1
812	431F-1830	EXHAUST CAUTION LABEL	1
813	431F-1862	GAS CHECK LABEL	1
813	431F-1863	GAS CHECK LABEL	1
814	BRR37-244	ON-OFF VALVE ASS'Y	1
815	308F-2070-3	CONVERSION KIT(FOR NG)	1
815	308F-2070-4	CONVERSION KIT(FOR LPG)	1
816	CP-74255-3	RATING PLATE SUPPORT LABEL	1
816	CP-74255-4	RATING PLATE SUPPORT LABEL	1
817	CP-74256-3	RATING PLATE SUPPORT LABEL	1
817	CP-74256-4	RATING PLATE SUPPORT LABEL	1
900	CP-30310	SCREW	
901	CP-30408	SCREW	
902	CP-30421-1	SCREW	
904	ZAA0316SZ	SCREW	
905	ZAA0422SZ	SCREW	
906	ZBA0408SZ	SCREW	
908	ZBB0410SC	SCREW	
909	ZBD0408SZ	SCREW	
910	ZDAA0410SZ	SCREW	
911	ZEAB0406SC	SCREW	
912	ZEAB0408SC	SCREW	
913	ZEAB0408SZ	SCREW	
914	ZEAB0408UK	SCREW	
915	ZEDB0408SB	SCREW	
916	ZEDB0408SZ	SCREW	
917	ZEDB0410SZ	SCREW	
918	ZEDB0412SZ	SCREW	
919	ZHAA0406SZ	SCREW	
920	ZHAA0410SZ	SCREW	
921	CP-30486-2	SCREW	

Consumer Support

Warranty Information

The installer is responsible for your heater's correct installation.

Please complete the information below to keep for your records:

Purchased from: _____

Address: _____ Phone: _____

Date of Purchase: _____

Model No.: _____

Serial No.: _____

Installed by: _____ Installer's License No.: _____

Address: _____ Phone: _____

Date of Installation: _____

Limited Warranty

RHFE-201FA Gas Direct Vent Wall Furnace

What is covered?

This Warranty covers any defects in materials or workmanship, subject to the terms stated below. This Warranty extends to the original purchaser and subsequent transferees, but only while the product remains at the site of the original installation. This Warranty only extends through the first installation of the product and terminates if the product is moved or reinstalled at a new location.

How long does coverage last?

Item	Period of Coverage
Heat Exchanger	10 years from date of purchase *
All Other Parts	5 years from date of purchase
Reasonable Labor	2 years from date of purchase

Limited Warranty - continued

What will Rinnai do?

Rinnai will repair any part or component that is defective in materials or workmanship as set forth as follows. All repair parts must be genuine Rinnai parts. All repairs or replacements must be performed by an individual or servicing company that has been authorized by Rinnai. Rinnai will pay reasonable labor charges associated with the repair or replacement of any part or component.

Replacement of the product may be authorized by Rinnai only. Rinnai does not authorize any person or company to assume for it any obligation or liability in connection with the replacement of a product. If Rinnai determines that repair of a product is not possible, Rinnai will replace the product with a comparable product, at Rinnai's discretion.

* If the Heat Exchanger fails due to a defect in material or workmanship within the sixth (6) through the tenth (10) year from the date of purchase, Rinnai will make the following allowances toward the purchase of a replacement Heat Exchanger:

Heat Exchanger	
Year of Failure	Allowance
6	50%
7	40%
8	30%
9	20%
10	10%

How do I get service?

You must contact a qualified/authorized service provider for the repair of a product under this Warranty. For the name of a qualified/authorized service provider please contact your place of purchase, visit the Rinnai website (www.rinnai.us), call Rinnai at 1-800-621-9419 or write to Rinnai at 103 International Drive, Peachtree City, Georgia 30269.

Proof of purchase is required to obtain warranty service. You may show proof of purchase with a dated sales receipt, or by registering within 30 days of purchasing the product. To register your appliance, please visit www.rinnairegistration.com. For those without internet access, please call 1-866-RINNAI1 (746-6241). Receipt of Registration by Rinnai will constitute proof-of-purchase for this product. However, Registration is not necessary in order to validate this Warranty.

What is not covered?

This Warranty does not cover any failures or operating difficulties due to accident, abuse, misuse, alteration, misapplication, force majeure, improper installation, improper conversion*, improper maintenance or service, or for any other causes other than defects in materials or workmanship. This Warranty does not apply to any product whose serial number or manufacture date has been defaced.

* Improper conversion includes conversions for inventory adjustment.

Rinnai is not liable for any special, incidental, indirect or consequential damages that may arise, including damage to person or property, loss of use, or inconvenience. Some states do not allow the exclusion or limitation of incidental or consequential damages, so the above limitation may not apply to you.

Limitation on implied warranties

Any implied warranties of merchantability and fitness arising under state law are limited in duration to the period of coverage provided by this limited Warranty, unless the period provided by state law is less. Some states do not allow limitations on how long an implied Warranty lasts, so the above limitation may not apply to you.

This Warranty gives you specific legal rights, and you may also have other rights which vary from state to state.

Ask about **Rinnai**

Rinnai's other fine products

Rinnai America Corporation
103 International Drive
Peachtree City, GA 30269
TOLL FREE: 1-800-621-9419
FAX: 678-829-1666
www.rinnai.us



Tankless Water Heaters

- Residential and Commercial Applications
- Continuous Hot Water
- Up to 9.8 GPM
- High Energy Efficiency
- Propane or Natural Gas
- Internal or External Installation
- Digital Temperature Control
- Small, Compact Design



Direct Vent Furnaces

- High Efficiency
- Cool-to-the-touch Cabinet
- Blower Included
- Vent Terminal A Included
- 556 and 1004 Models Available in Beige, White and Silver
- Gas Conversion Kit Included



Direct-Vent Fireplace, RHFE-750ETR

- Up to 83% AFUE Energy Efficiency
- Zero-Clearance Installation
- Available in Four Options of Fronts
- Remotes and Fan Included
- Gas Conversion Kit Available



Hydronic Air Handler

- Designed for Use with Rinnai Systems
- Domestic Hot Water Priority
- Optional Programmable Thermostat
- Zero Clearance to Combustibles
- Accommodates Standard Cased-Coils

Register your product at www.rinnairegistration.com
or call 1-866-RINNAI1 (746-6241)

Rinnai

AMERICA CORPORATION

103 International Drive,
Peachtree City, Georgia 30269
Tel:1-800-621-9419
Fax:1-888-474-6624
www.rinnai.us

Register your product at www.rinnairegistration.com or
call 1-866-RINNAI1 (746-6241)

201F-2050×03(00)

Printed in Japan 2008.09



108466