

INSPECT FOR DAMAGE.

NOTE: Inspect materials for concealed shipping damage. You only have 11 days to file a freight claim. If items are damaged or missing please call Myson at 1-800-698-9690.

INSPECTION FOR COMPLETENESS

Un-pack the Select Radiator carefully to avoid damage or loss of parts.

The Select Radiator should come with the following parts.

- . 2- Concrete wall brackets
 - . 4- Plastic inserts for noise suppression
 - . 2- Conventional wall framing brackets
 - . 1- Stainless steel solid plug
 - . 1- Stainless steel air vent plug.
 - . 1- Tube of Loctite 565
- [Radiators over 62 inches have 3 brackets]

INTRODUCTION

The Myson Select Radiator will keep any room in comfort and style. We at Myson Inc. thank you for your purchase of the Select Radiator. Each radiator combines Myson's compact design and advanced steel construction with a durable baked epoxy/polyester enamel power coat finish. Myson's sleek styling and thorough testing provides attractiveness and dependability. Myson's goal is to assure the highest performance, quality, reliability and outstanding customer service.

CAUTION

1. Read this entire instruction manual thoroughly before beginning installation.
2. To ensure full efficiency of your Myson Select Steel Panel Radiator, please follow all the instructions carefully observing the caution notes for each step.
3. Failure to follow to follow these instructions will invalidate the manufacturer's warranty.



Application:

Myson radiators are only for use in recirculating closed loop hydronic-heating systems. These radiators are not recommended for gravity systems. Myson Select Radiators are designed to work with a maximum working pressure of 78 PSI and no more than 212 degrees F water temperature.

DO NOT USE STEAM IN THESE RADIATORS.



Design and layout conditions:

Myson Select Radiators should only be used with a recirculation pump closed loop hydronic heating system. Please consult national and local codes for specific restrictions that may be imposed on your installation. Position your radiator away from your circulator pump to avoid either excess suction that could force water out through the integral air vent or draw air into the system. The preferred positioning for the Select radiator is below a window where it can minimize downdrafts from glazed areas.

Myson Radiators may be hot to the touch. Generally the surface temperature is at 10-12 degrees Fahrenheit below system water temperature. Care must be taken to consider room occupant's ability to sense or understand that radiators may be hot.

Should radiator surface or system water temperature be an issue please contact MYSON at 1-800-698-9690 for information on the MYSON LST radiators LST-(Low Surface Temperature) Radiators can be a viable solution where temperatures are a safety concern.

Information Symbols

NOTE: You will see these symbols within the text of this manual, drawing your attention to important information.



Myson products are designed to be installed by professional trades people. Myson instructions are meant to be thorough; however it is assumed that the installer has the appropriate technical knowledge related to buildings codes, standard trade practices, and proper use of the tools of the trade. Should a homeowner without such knowledge or skill take it upon him/herself to attempt the installation, Myson will not be responsible for any damages, injuries or unsatisfactory performance of the Myson product used.

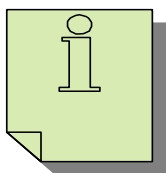

Information following this symbol indicates that it is important for the correct installation or use of the product. Failure to heed this information may affect the performance or useful life of the product. Risk of property damage or personal injury is low.



Information following this symbol must be followed without exception. Failure to follow these directions could result in moderate property damage or the possibility of personal injury.

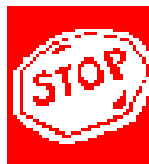

Information following this sign must be carefully followed without exception. Failure to do so could result in significant and extensive property damage or serious personal injury or death.

MYSON

948 HERCULES DRIVE, SUITE 5
COLCHESTER, VT 05446
1-800-698-9690
FAX 802-654-7022

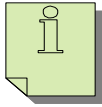

Step # 1. Locate studs in wall where the radiator is to be mounted.

Step # 2. Mount the brackets so the radiator is a minimum of 4 inches off the floor.

- . Failure to allow 4" minimum clearance below radiator can significantly reduce radiator performance.
- . Attach brackets firmly to the studs using appropriate hardware making sure the spring loaded connection on brackets is on top.
- . All Select Radiators use 2 brackets except 160G and 180G use 3 brackets
- . Use a level to assure bracket is plumb.

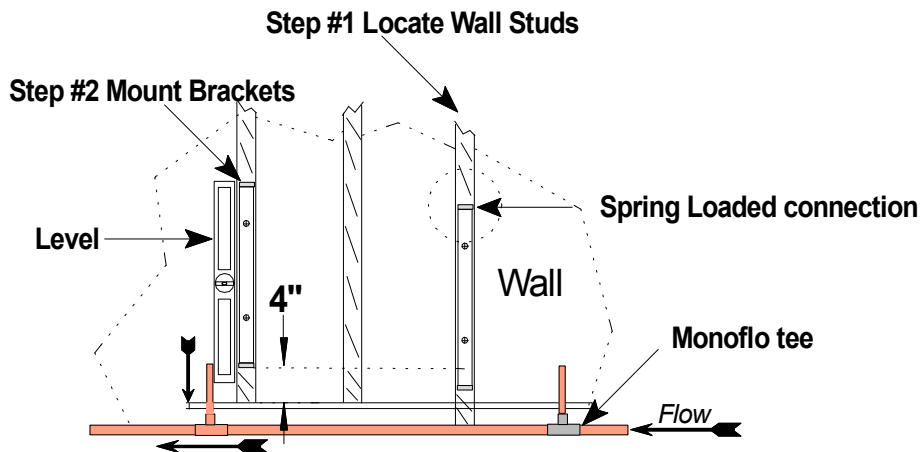

Step # 3. To install the radiator on the brackets set the top edge of the top grill into the upper part of the bracket then gently lift and snap the bottom into the lower part of the bracket.

Step # 4. Position radiator to line up with the supply and return pipes.

Step # 4 Radiator mounting on bracket.

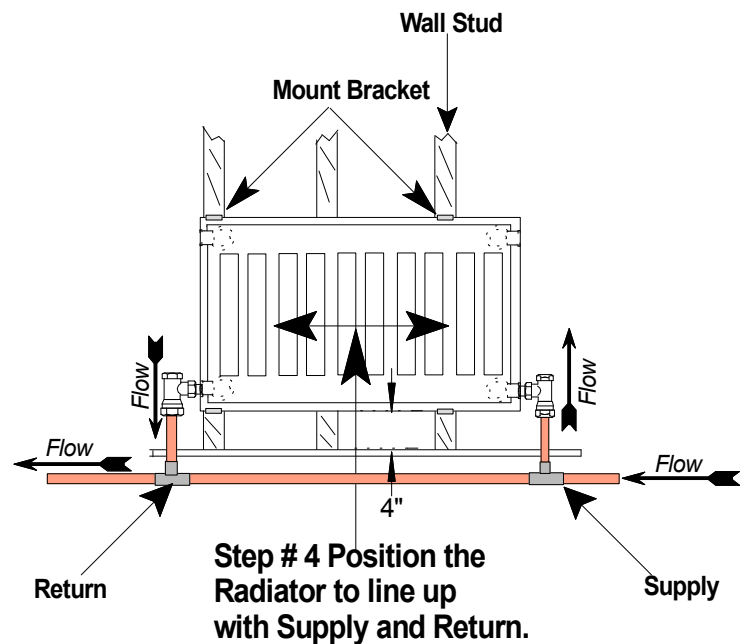
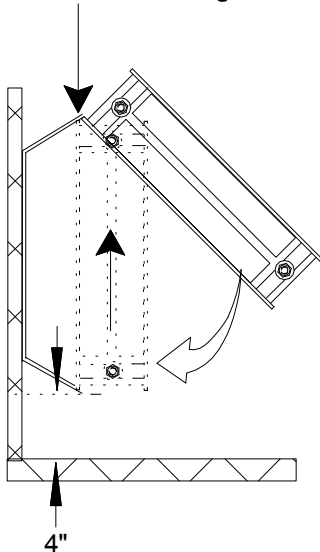

Many MYSON products are in excess of 70 pounds. Care should be taken to have help to lift larger radiators into place to avoid lifting injuries.



Step # 1. Position radiator to line up with the supply and return pipes.

Step # 2. Position brackets on wall so that they line up with the centerline of the brackets on the rear of the Select Radiator.

Step # 3. Mount the brackets so the radiator is a minimum of 4 inches off the floor.



. Failure to maintain 4" minimum clearance to floor can significantly reduce radiators performance.

. Attach brackets firmly to the wall using appropriate hardware.

. Use a level to assure bracket is plumb.



Step # 4. Place plastic inserts into the two slots on each bracket that will mount the radiator.

. Failure to use nylon inserts will increase the likelihood of expansion noise as radiator heats and cools. Many people find the noise annoying in an otherwise silent heating system.

Step # 5. Lift and seat the radiator onto the brackets.

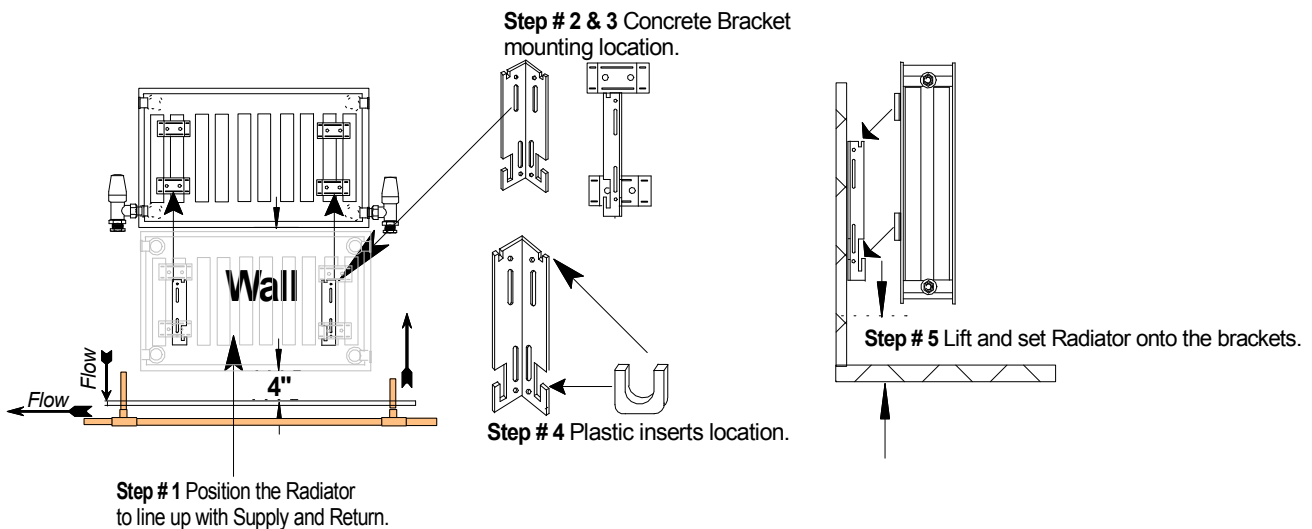

Many Myson Radiators are in excess of 70 pounds. Care should be taken to have help to lift larger radiators into place to avoid lifting injuries.

Select Mounting Bracket Locations.

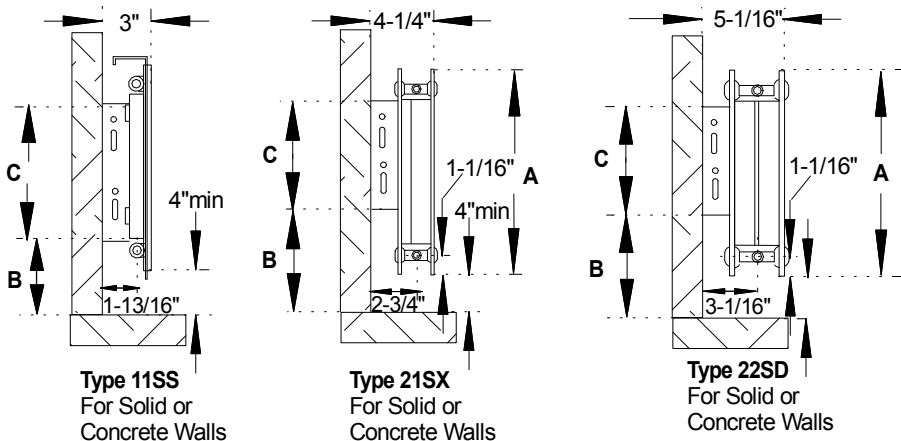

NORMAL HEIGHT	A	B	C
12"	11-13/16"	6-1/4"	6-1/4"
16"	15-3/4"	8-3/16"	6-1/4"
24"	23-5/5"	9"	12-3/8"
28"	27-9*16"	10-15/16"	12-3/8"

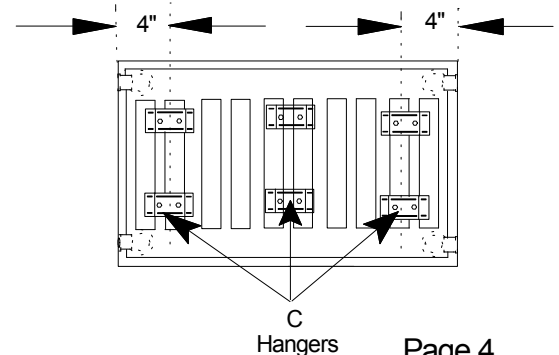

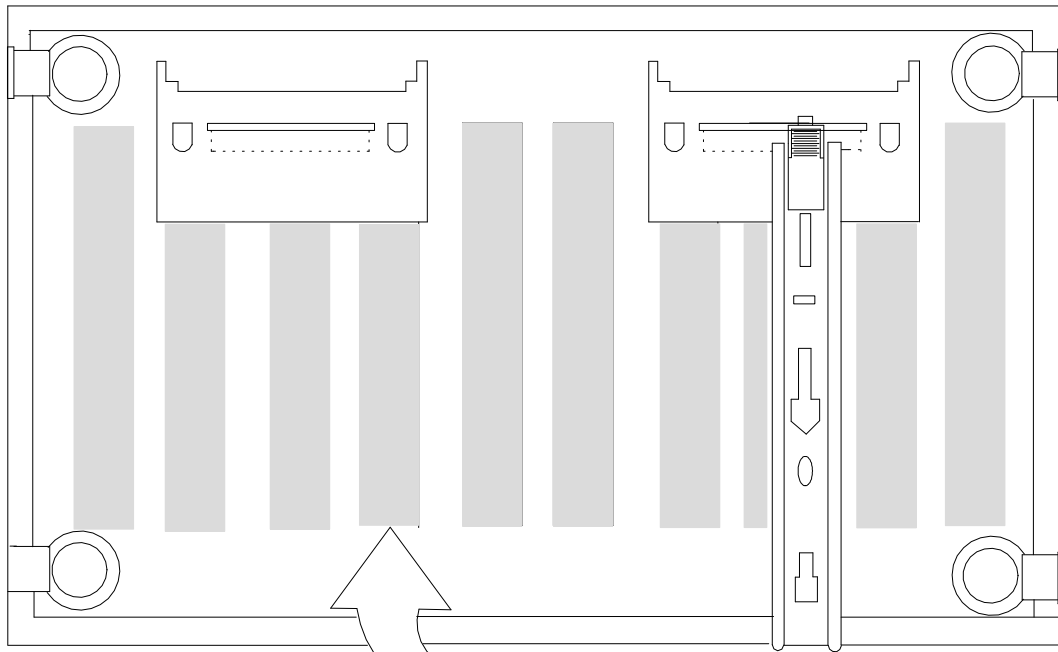

Fins

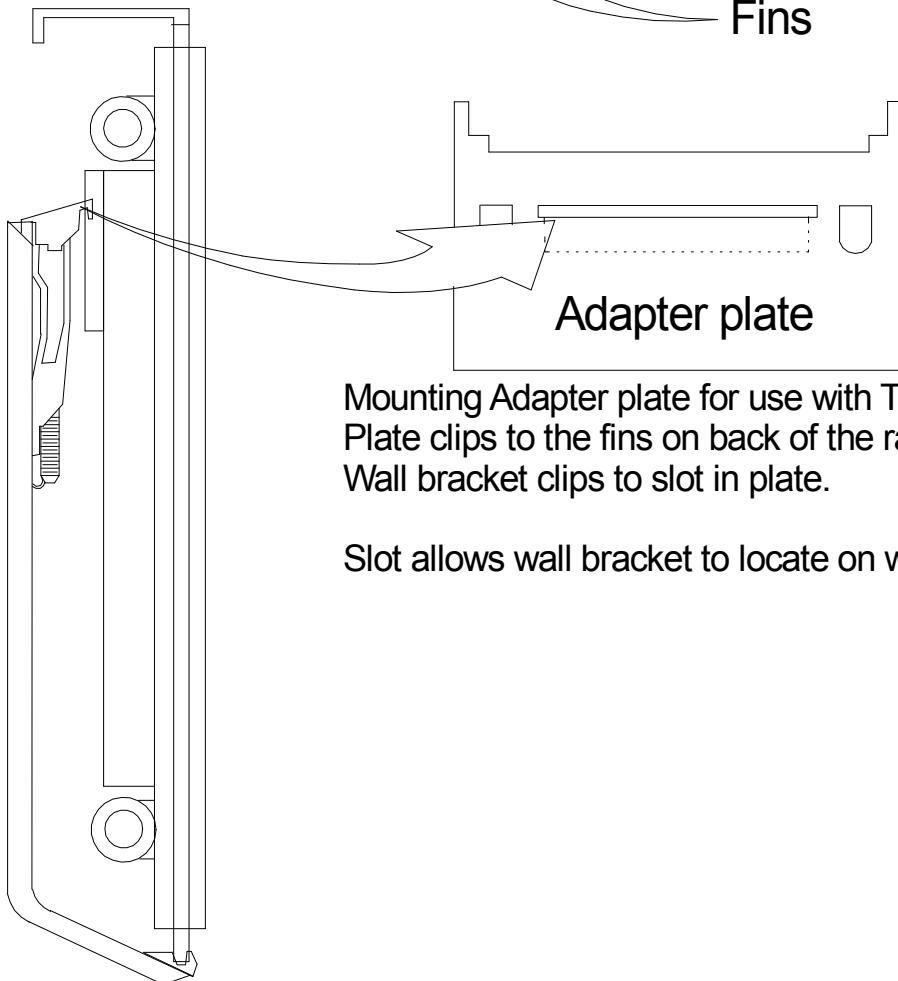

Adapter plate

Mounting Adapter plate for use with Type 11G Select Radiators.
Plate clips to the fins on back of the radiator.
Wall bracket clips to slot in plate.

Slot allows wall bracket to locate on wall stud.

P

The following drawings are general examples.
Consult a certified heating professional for your specific application.

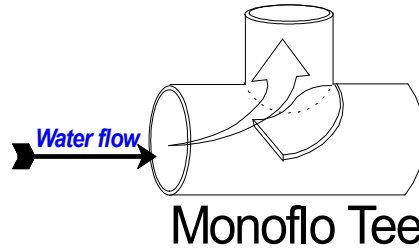
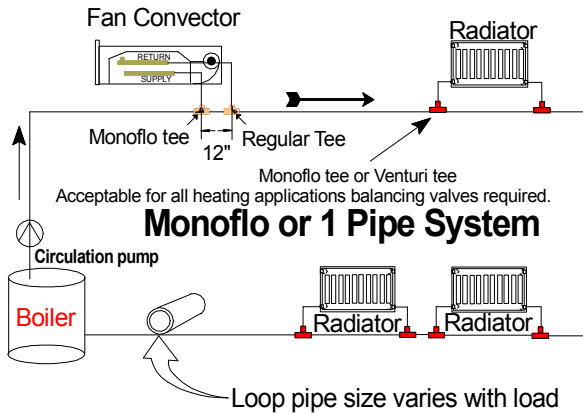

General information on the use of Monoflo tees:

- Scoop type is placed on the supply.
- Venturi Type on the return.
- If heating unit is below main or more the 4 feet horizontally from the main use two monoflow tees facing each other.

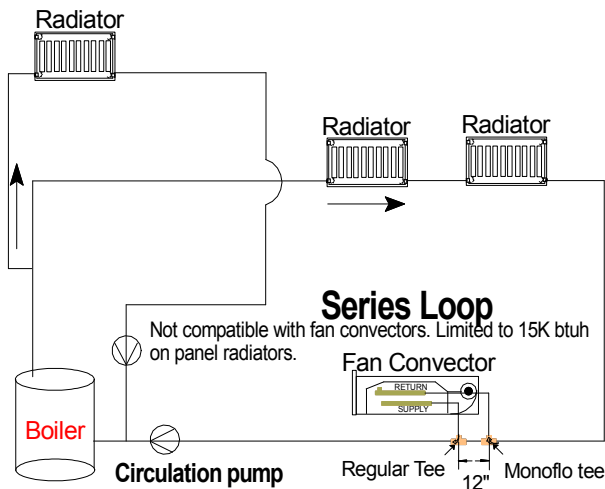

A single fan convector may be added to a series loop using monoflo tees.

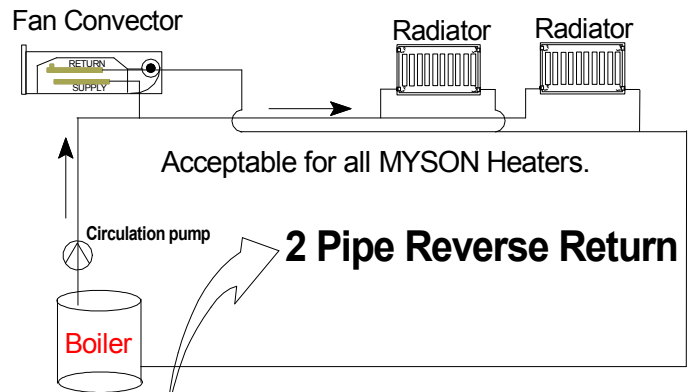

When mixing radiators of different head loss. i.e. fan convectors with radiators, balancing is often required to ensure proper flow through the fan convector.

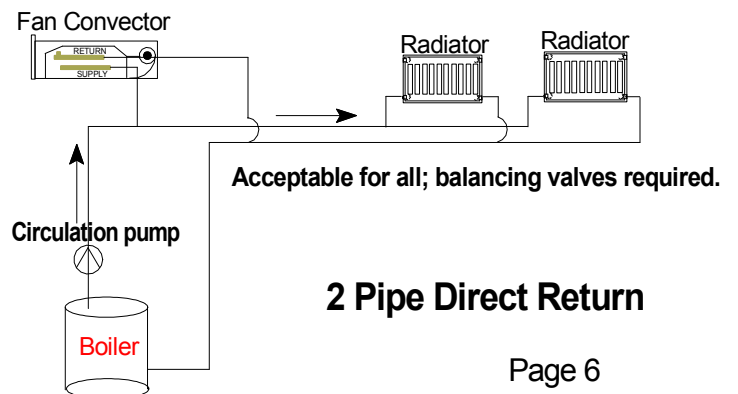
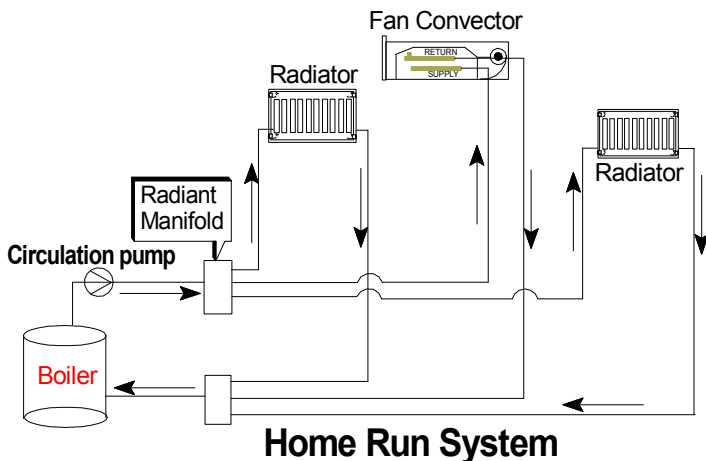



Rough-ins given are for MYSON TRV & Control Valves only. Valve specifications vary by manufacturer. Myson will not be responsible for damage or repair of property for rough-in dimensions with non-Myson Valves. Prior to committing pipe work behind finish floor or wall materials consult Myson for assistance at 1-800-698-9690.

Dimensions in inches. All valves are by MYSON and are 1/2" thread engagement in a vertical pattern. For 2 LKD valves use LKD & TRV dimensions.

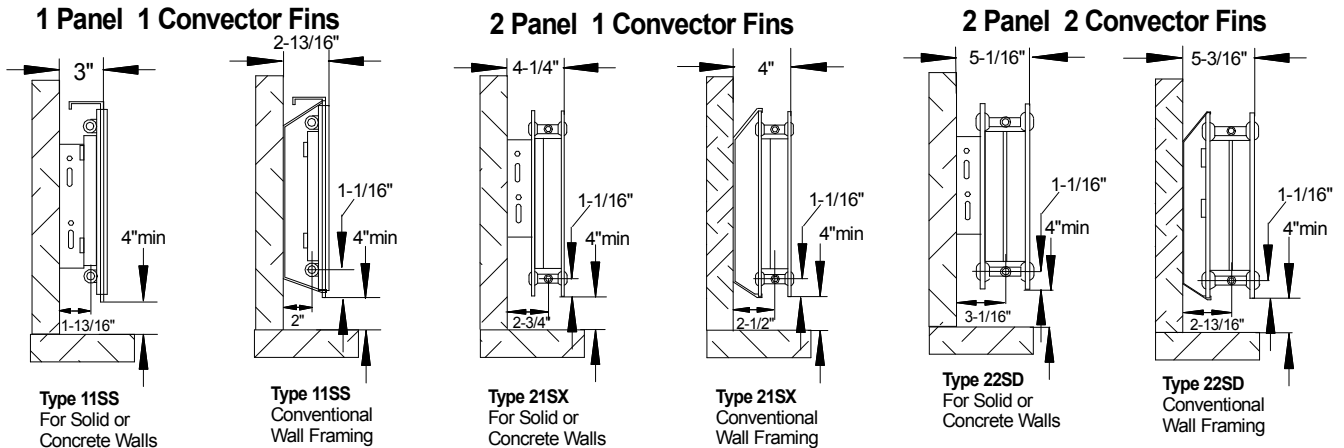

It is not recommended to route piping through the walls for single panel radiators (TYPE 11) as there is generally insufficient room to leave the wall and make the angle into the radiator.

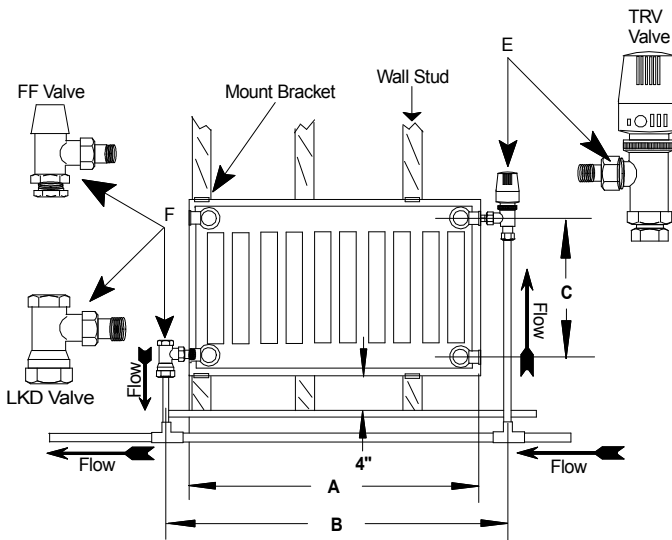

NOM	SIZE	"C"
HEIGHT		
12	30	9 11/16"
16	40	13 5/8"
24	60	21 1/2"
28	70	25 7/16"

Model	Actual Length	LKD & FF Valves	LKD & TRV Valves	(2) DAV12 Valves	TRV & DAV12 Valves
	A	B	B	B	B
40G	15 3/4"	19 3/8"	19 1/8"	18 3/4"	19"
50G	19 11/16"	23 5/16"	23 3/16"	22 11/16"	22 15/16"
60G	23 5/8"	27 1/4"	27 1/8"	26 3/8"	26 7/8"
70G	27 9/16"	31 3/16"	31 1/16"	30 9/16"	30 13/16"
80G	31 1/2"	35 1/8"	35"	34 1/2"	34 3/4"
90G	35 7/16"	39 1/16"	38 15/16"	38 7/16"	38 11/16"
100G	39 3/8"	43"	42 7/8"	42 3/8"	42 5/8"
110G	43 5/16"	46 15/16"	46 13/16"	46 5/16"	46 9/16"
120G	47 1/4"	50 7/8"	50 3/4"	50 1/4"	50 1/2"
130G	51 3/16"	54 13/16"	54 11/16"	54 3/16"	54 7/16"
140G	55 1/8"	58 3/4"	58 5/8"	58 1/8"	58 3/8"
160G	63"	66 5/8"	66 1/2"	66"	66 1/4"
180G	70 7/8"	74 1/2"	74 3/8"	73 7/8"	74 1/8"



CONNECTIONS:

1. Myson Select Radiators come with four 1/2" BSPT connections located at the top and the bottom of both sides of the radiator.

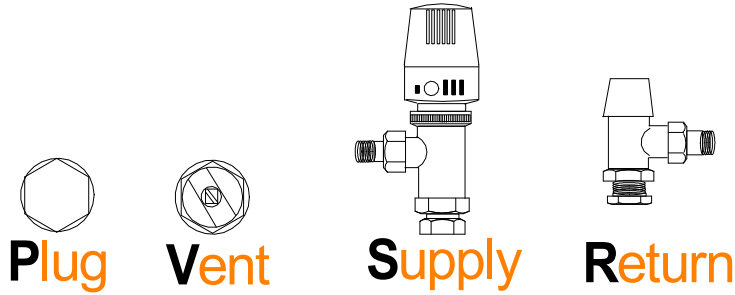

Preferred methods A,B,C,D

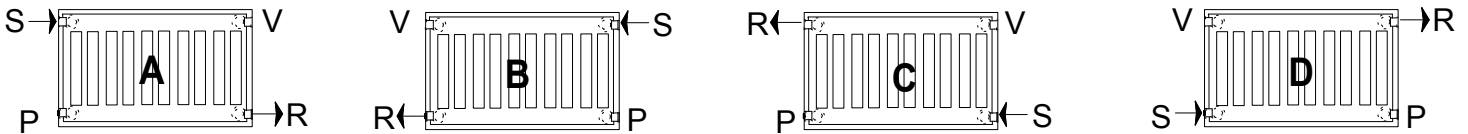

Alternate methods E,F,G,H derate radiation by 5%

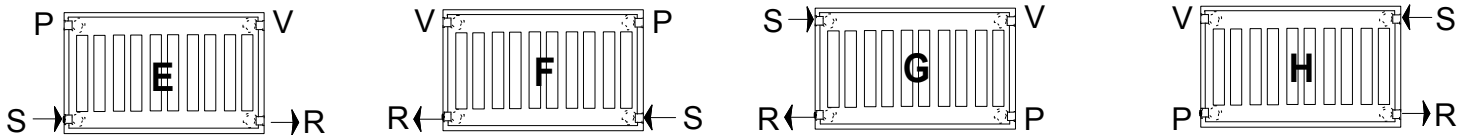

All Myson Radiators are shipped with nylon paint plugs. All plugs must be removed & replaced by the appropriate plug, vent or valve. Failure to use Myson supplied plugs may result in significant water damage!



Select Radiator Connection Options

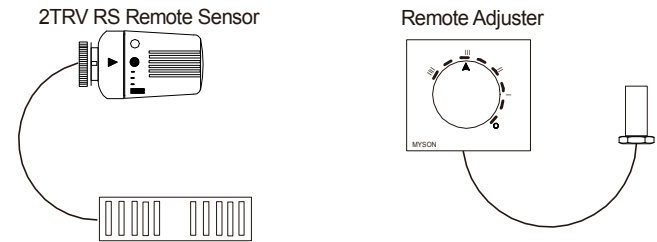
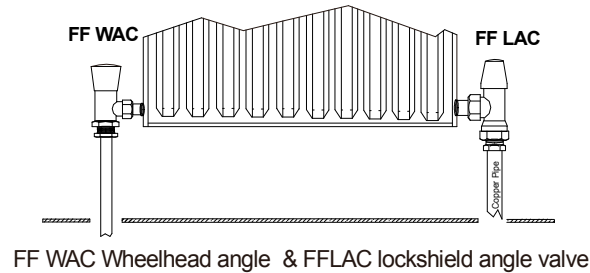
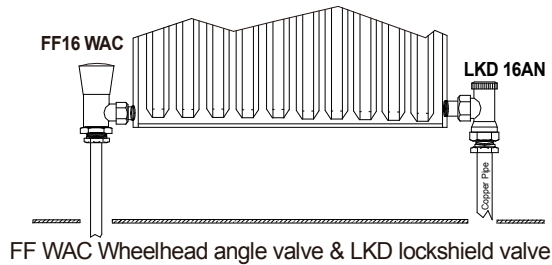
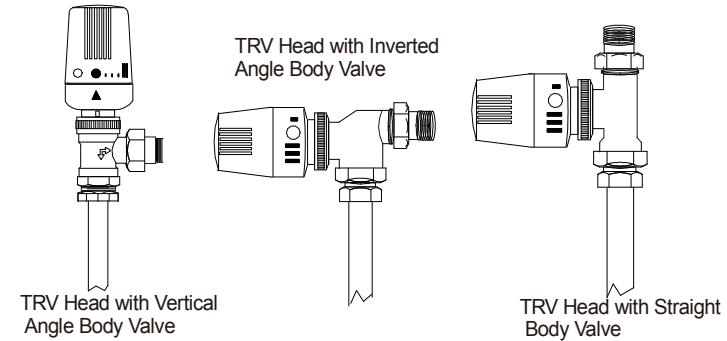
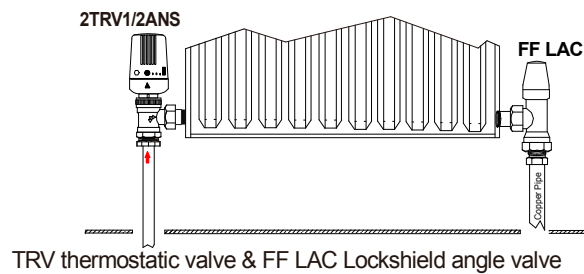
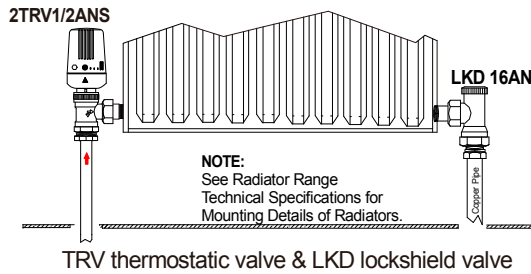

For best accuracy 2TRV2 head should be in a horizontal position away from heat source. Remote Sensor or Adjuster heads are available

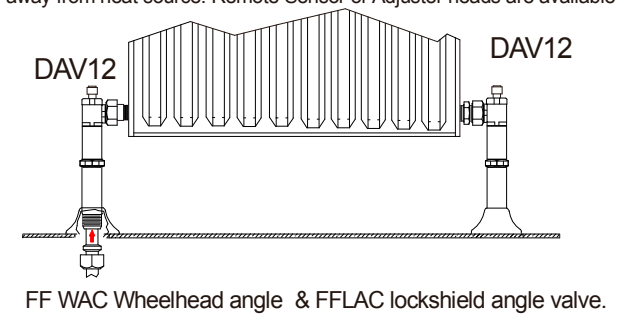
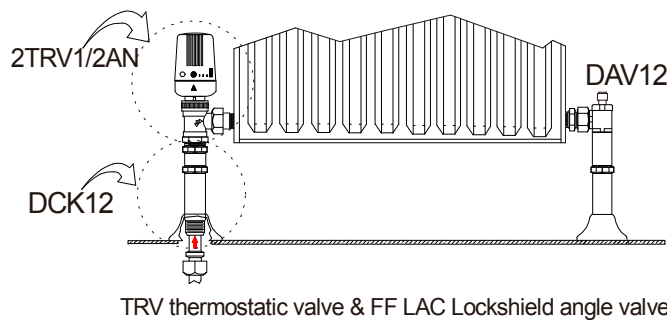
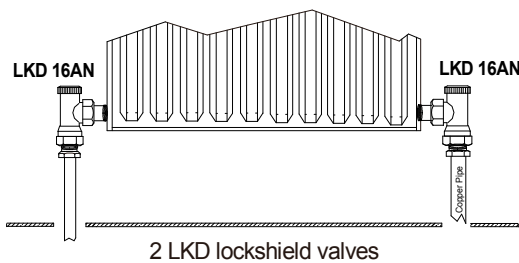

(FF LAC)... Valve is set full open and white knob will not turn. Angle only.

(FF WAC)... Valve white knob can turn to open or close the valve. Angle only.

(LKD)..... Valve has chrome cap that can be removed exposing an adjustment screw to open or close the valve. Angle or straight.

(TRV)..... Valve is a non electric thermostatic valve that modulates water flow in response to changes in room temperature and closes when set temperature is achieved NOTE: This valve will not turn on or shut off your heating system. Horizontal angle, vertical angle or straight pattern.

(DCK12)..... Pipe extension with compression fitting and escutcheon for use with the 2TRV1/2ANS valve.

(DAV12) Manual valve, Adjust flow with allen wrench. Valve comes with pipe chrome extension with compression fitting and escutcheon .



Nylon shipping plugs are meant solely for keeping paint from radiator threads during the painting process. Failure to remove plastic plugs and inserting the stainless metal plugs can result in significant property damage if heating system is run with plastic plugs in place.

- Step # 1** Remove all plastic shipping plugs on the radiator.
- Step # 2** Before proceeding clean tappings of any foreign material
- Step # 3** Install air vent plug.
- Step # 4** Install blanking plugs.

NOTE: See page (5) for alternate valve and plug locations.

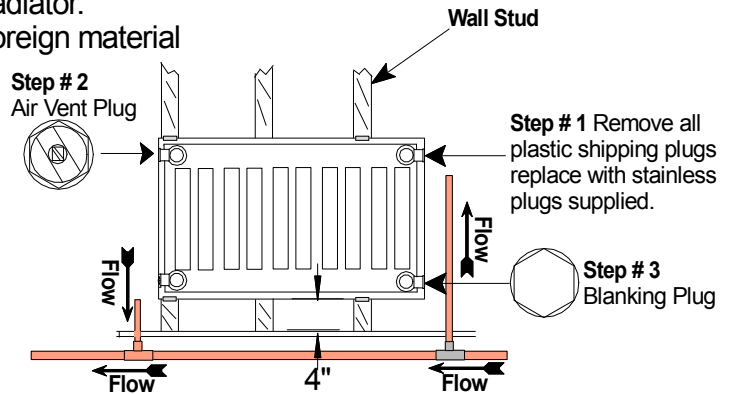

- Step # 5** Apply teflon tape or compound to the threaded nipple on the valve.
- Step # 6** Thread the nipple of the valve into the radiator using a 12 mm Allen wrench
- CAUTION:** Do not over tighten and do not use a pipe wrench on ground joint .
- Step # 7** Cut the copper pipe to a correct length.
- NOTE:** The pipe must fit all the way up to the stop in the valve body. (approx 1" into the valve body)
- Step # 8** Place compression nut on copper pipe.
- Step # 9** Place Compression ring on copper pipe.
- CAUTION:** DO NOT DAMAGE THE COMPRESSION RING.
- Step # 10** Attach valve to valve nipple and tighten coupling. Turning valve body can damage compression ring
- CAUTION:** DO NOT rotate valve body. Turn compression nut only and DO NOT OVER TIGHTEN.
- Step # 11** Tighten compression nut.

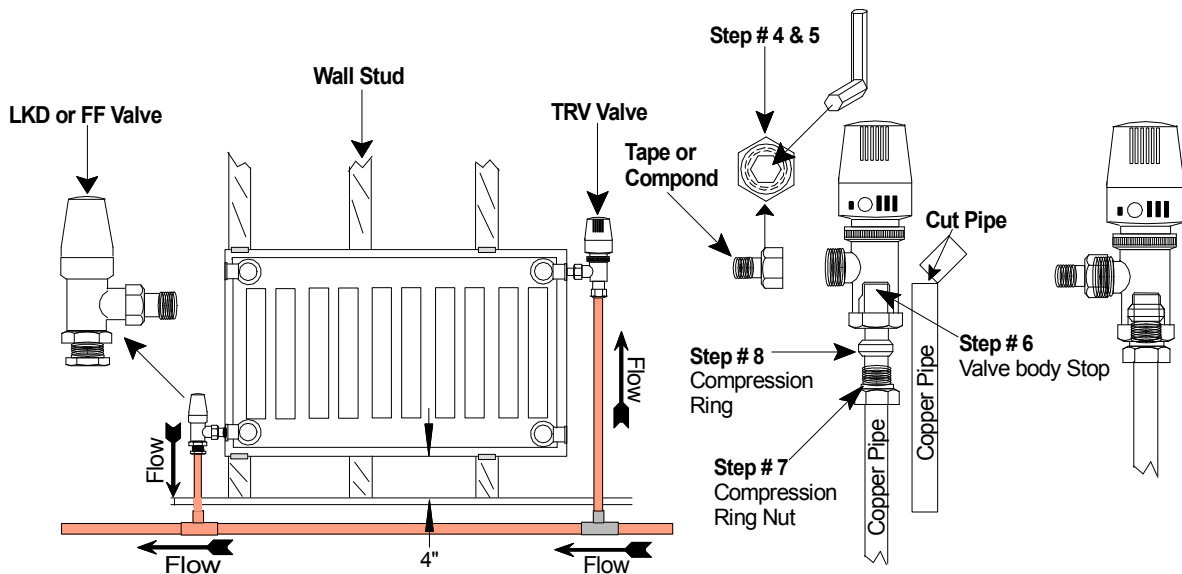

If glycol is to be added to the system for freezing protection extra care must be taken to seal connections fully with teflon or pipe dope.



Myson products are designed to be installed by professional trades people.

Myson instructions are meant to be thorough; however it is assumed that the installer has the appropriate technical knowledge related to building codes, standard trade practices, and proper use of the tools of the trade. Should a homeowner without such knowledge or skill take it upon him/herself to attempt the installation, Myson will not be responsible for any damages, injuries or unsatisfactory performance of the Myson product used.

NOTE: MYSON products have **BSP** male and female threads. BSP threads are a straight running thread **NOT tapered like NPT**.

Myson Radiator Valves are designed with BSP threads at radiator side & NPT or compression connections to system piping

1. Clean all threaded surfaces (both external & internal) .
2. Location (A) Apply a 360 degree bead of Loctite 565 to the leading thread of the male fitting, **leaving the first thread free**. Force the sealant into the threads to thoroughly fill the voids..
3. Using accepted trade practices assemble and wrench tighten fittings until proper alignment is obtained.
4. Properly installed fittings will seal to moderate liquid pressures in 30 minutes. For maximum pressure resistance allow the Loctite to cure for a minimum of 24 hours.

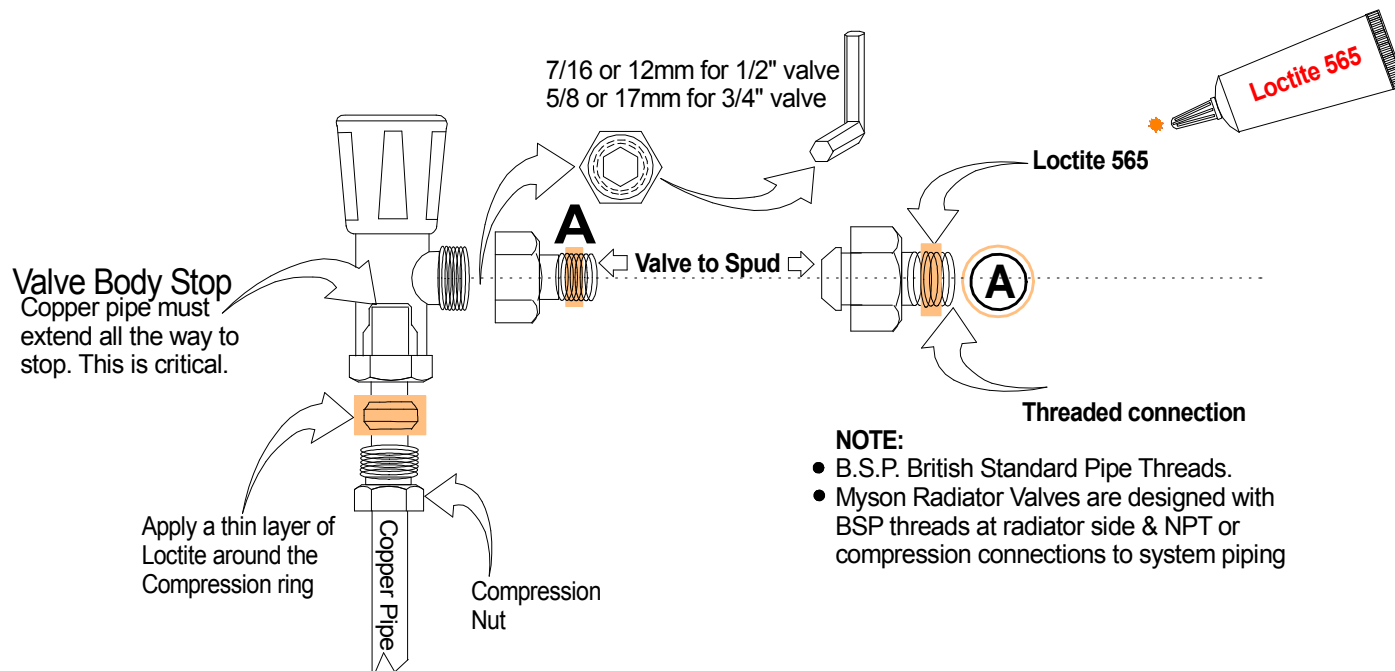



Failure to flush system of debris and flux may cause premature radiator failure, which can result in leaks and property damage NOT covered under the Myson Warranty.

SYSTEM STARTUP:



1. Fill and vent the system.
2. Run the system for two (2) hours at full temperature with all radiator valves in the open position.
3. Shut off and drain the system while the water is still hot.
4. Refill and drain the system.
5. Reheat, vent, and balance the system.
6. Once the Select Radiator is filled with water the system should be left filled.
7. System should be checked for leaks on seasonal start-ups. Leaks must be repaired as automatic system fill valves allow fresh water/oxygen into the system attacking radiators internally



MAINTENANCE & CLEANING.

1. Once operating, avoid the introduction of fresh water and oxygen to the system to prevent corrosion.
2. An occasional wiping with a damp cloth using a non abrasive detergent can protect the finish of your Myson Select Panel Radiator.
3. The use of abrasive cleaners will damage the surface of your radiator, and void the manufacturer's warranty.

ADDITIVES:



Treatment of the primary water is not usually required in a properly designed system. Treatment may be necessary if either.

1. Local waters are known for their content of corrosive or if high bacterial levels are present.
2. If there is a possibility that the system may be idle during a prolonged period of freezing temperatures, system should be either drained or protected with antifreeze.
If either corrosion inhibitors or anti freeze is to be used it should be added **AFTER** the system has been flushed in the final stages. Use only anti-freeze suitable for potable water.



Do not put heating system into operation without checking for leaks with the system up to full operating temperature. Leaks can appear in a heated system that were not noticeable with a cold system or air pressure check.