

## Myson Eclipse IVC Radiators

Myson Eclipse Radiators are available with Internal Valve Control (IVC). Each radiator is factory fitted with an easily adjustable presetting valve insert which, with the help of an adaptor ring, can be fitted with the Myson thermostatic head. As all of the pipework is hidden within the radiator convectors, installation is quick, easy and flexible and leaves no unsightly connections.

The flow pipe ascends behind the front panel and connects to the thermostatic valve body. The flow and return connections are incorporated at the bottom of the radiator and are set at a standard 2" spacing.

IVC's are standard in right hand connections. They are assembled for two pipe operation, but can be adapted for one pipe operation by the use of suitable external valves.

The thermostatic head can be fitted as the final operation of the installation, and there is a facility for fitting alternative heads with the use of adaptors.

The integral thermostatic control of room temperature saves valuable energy.

### BRACKETS

Myson concealed brackets are packed with every radiator. In addition, a set of wall brackets for use with conventional wall framing is supplied.

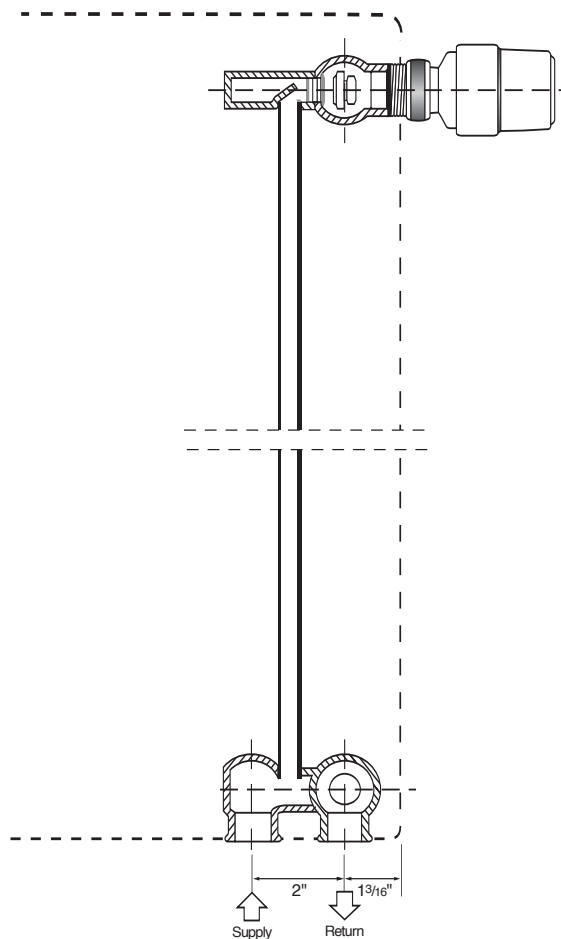
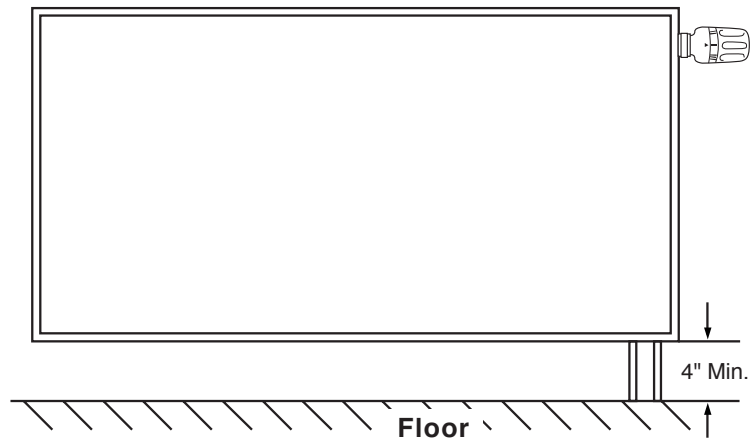

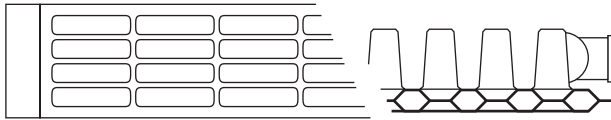

## Eclipse Type 11G Single Convactor (IVC)

Nominal Height (in)	Actual Height (in)	Actual Length (in)	Output (Btu/hr)	Order Code	Weight (lbs)	Water Content (gals)
16	15 3/4	23 5/8	1745	PP 11 4060	25.9	0.3
		31 1/2	2329	PP 11 4080	32.4	0.3
		39 3/8	2910	PP 11 40100	38.5	0.4
		47 1/4	3490	PP 11 40120	44.9	0.5
		55 1/8	4074	PP 11 40140	51.3	0.5
		63	4655	PP 11 40160	57.5	0.6
		70 7/8	5239	PP 11 40180	63.8	0.6
		78 3/4	5819	PP 11 40200	70.0	0.7
24	23 5/8	23 5/8	2503	PP 11 6060	36.3	0.3
		31 1/2	3337	PP 11 6080	46.2	0.4
		39 3/8	4170	PP 11 60100	56.1	0.5
		47 1/4	5003	PP 11 60120	65.8	0.6
		55 1/8	5840	PP 11 60140	75.8	0.7
		63	6673	PP 11 60160	85.7	0.8
		70 7/8	7507	PP 11 60180	95.6	0.9
		78 3/4	8340	PP 11 60200	105.3	1.0

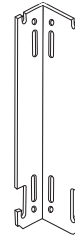

Wall bracket & plastic insert for use with **solid or concrete walls**. (supplied)

## Eclipse Mounting Panel for Bracket Installation

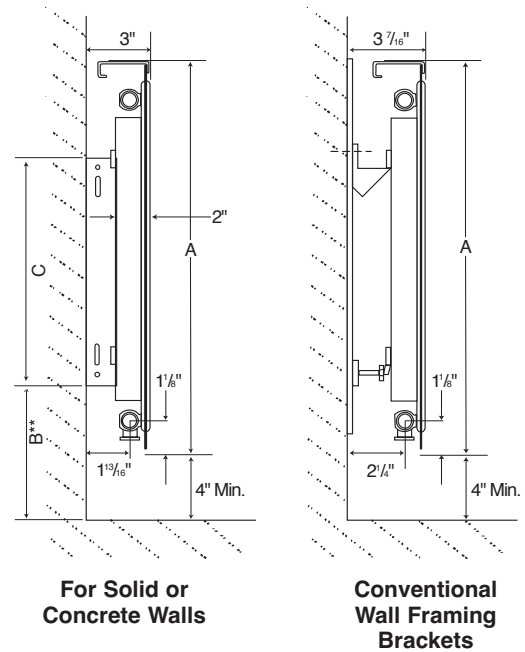

Nominal Height	A	B**	C
16"	15 3/4"	8 3/16"	6 1/4"
24"	23 5/8"	9"	12 3/8"

\*\* Includes a minimum clearance of 4" from floor to bottom of radiator

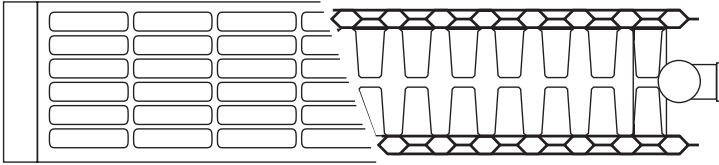

## Eclipse Type 22G Double Convactor (IVC)

Nominal Height (in)	Actual Height (in)	Actual Length (in)	Output (Btu/hr)	Order Code	Weight (lbs)	Water Content (gals)
16	15 3/4	23 5/8	3016	PP 22 4060	36.7	0.6
		31 1/2	4023	PP 22 4080	48.2	0.8
		39 3/8	5027	PP 22 40100	57.9	1.0
		47 1/4	6034	PP 22 40120	67.6	1.1
		55 1/8	7039	PP 22 40140	77.3	1.3
		63	8046	PP 22 40160	87.0	1.5
		70 7/8	9050	PP 22 40180	96.7	1.6
	78 3/4	10058	PP 22 40200	106.4	1.8	
24	23 5/8	23 5/8	4863	PP 22 6060	55.7	0.9
		31 1/2	5656	PP 22 6080	71.6	1.1
		39 3/8	7069	PP 22 60100	87.4	1.3
		47 1/4	8483	PP 22 60120	103.1	1.6
		55 1/8	9897	PP 22 60140	119.0	1.8
		63	11311	PP 22 60160	134.6	2.1
		70 7/8	12725	PP 22 60180	150.5	2.3
	78 3/4	14139	PP 22 60200	166.1	2.6	

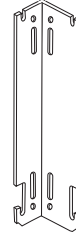

Wall bracket & plastic insert for use with **solid or concrete walls**. (supplied)

## Eclipse Side Profile with Brackets

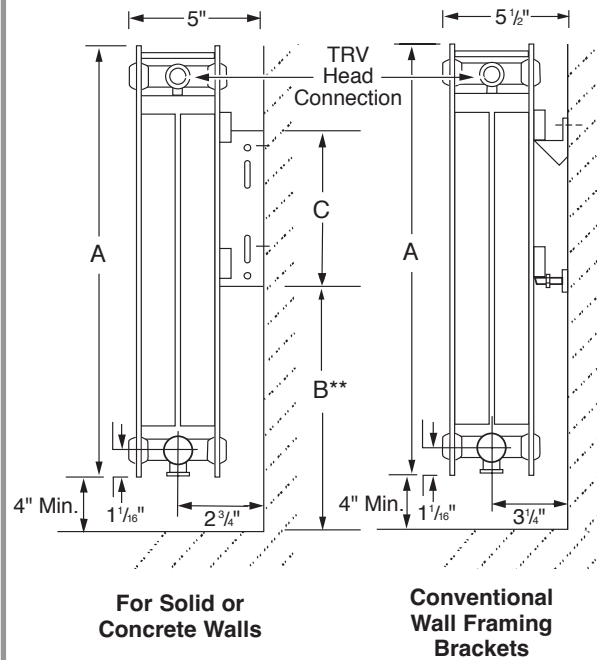

Nominal Height	A	B**	C
16"	15 3/4"	8 3/16"	6 1/4"
24"	23 5/8"	9"	12 3/8"

\*\* Includes a minimum clearance of 4" from floor to bottom of radiator

**Pressure Loss Graphs**

*For Compact and IVC Radiators*

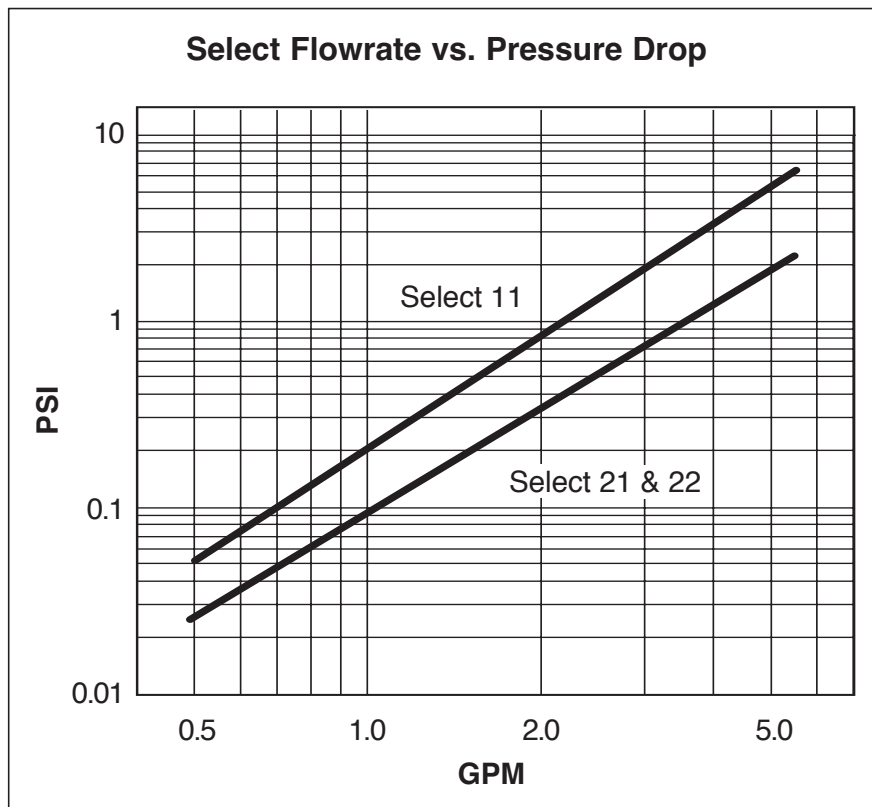
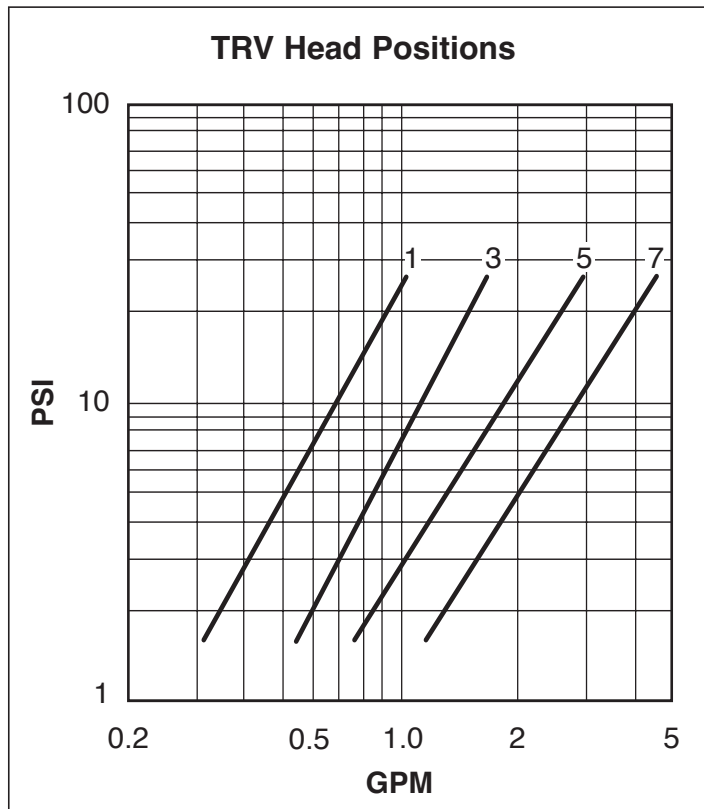

## Pressure Loss Graphs

For Compact and IVC Radiators

### Valve Setting

	1	2	3	4	5	6max	kPa
gpm			0.12				
	0.02	0.06	0.39	0.18	0.26	0.31	0.66
	0.07	0.18	1.23	0.58	0.84	0.97	2.09
	0.22	0.56		1.83	2.64	3.08	6.60

$$Q=Cv+\text{Sqrt}(\Delta P)$$

0.06	0.15	0.32	0.48	0.69	0.81	1.73
------	------	------	------	------	------	------

Pressure Loss and Presetting

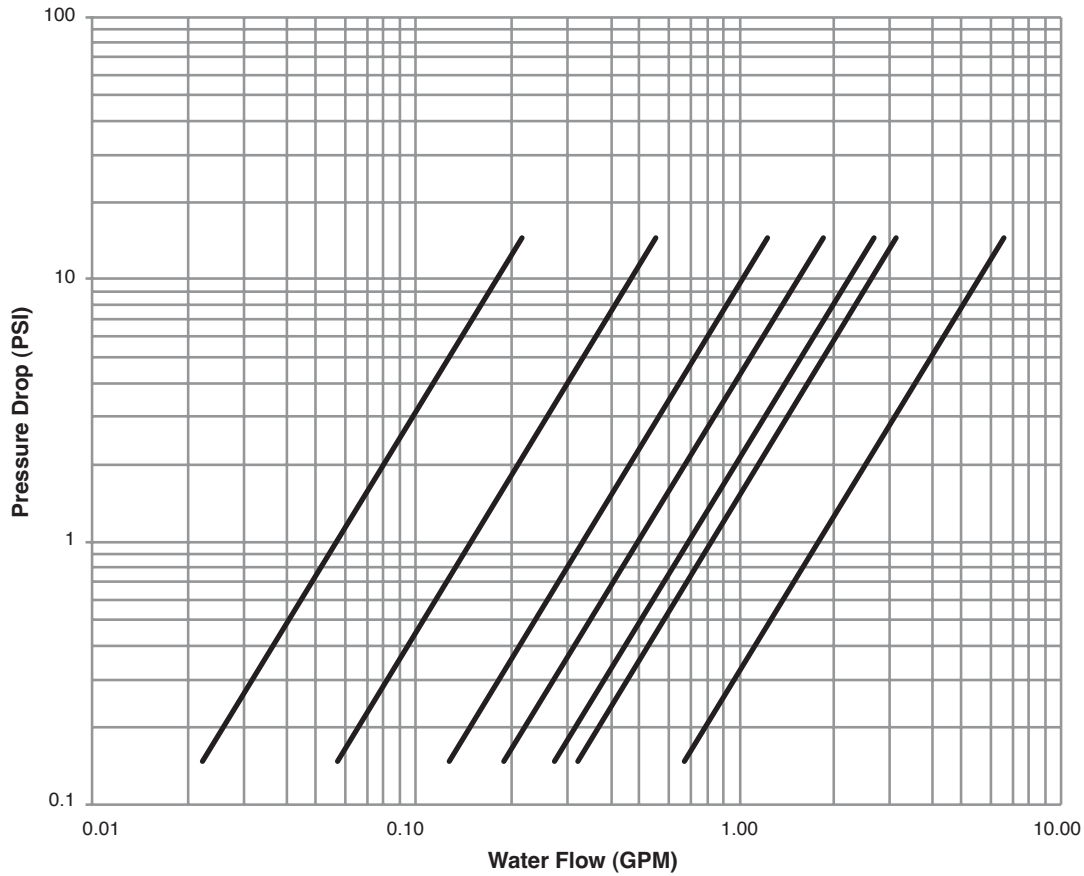

## Heat Output Adjustment Factors

### Temperature Difference<sup>1</sup>

°F	65	70	75	80	85	90	95	100	105	110	115	120	125	130
°C	36	39	42	44	47	50	53	56	58	61	64	67	69	72

### Adjustment Multiplier

0.53	0.59	0.64	0.69	0.74	0.80	0.85	0.91	0.97	1.02	1.08	1.14	1.20	1.26
------	------	------	------	------	------	------	------	------	------	------	------	------	------

<sup>1</sup>Certified heat output is based upon tests conducted at a room temperature of 68°F (20°C) and a mean water temperature of 176°F (80°C) using T.B.O.E. (Top, Bottom, Opposite End) connections. For temperature differences other than 108°F (60°C) used for these tests, multiply the heat output (given in the table above) by the adjustment multiplier given in this table which correspond to the desired performance conditions. B.O.E. (Bottom, Opposite End) connections give slightly lower heat output.

## Selection of Sizes

Myson has a Select or Eclipse Radiator model to meet every room situation and Btu output requirement. The following examples use Select models.

**Select SX-70-90G**  
**Heat Output:** 5702 Btu/hr  
**Length:** 35.4"  
**Water Content:** 1.71 gal

28"

**Select SX-60-100G**  
**Heat Output:** 5582 Btu/hr  
**Length:** 39.4"  
**Water Content:** 1.63 gal

24"

**Select SX-40-160G**  
**Heat Output:** 6344 Btu/hr  
**Length:** 63"  
**Water Content:** 1.66 gal

16"

**Select SX-30-180G**  
**Heat Output:** 5570 Btu/hr  
**Length:** 70.9"  
**Water Content:** 1.60 gal

12"

### STEP 1: Determine the heat output rating needed.

Use the tables (above) to determine the Heat Output Rating required for a specific situation. See the example below.

### STEP 2: Check the locations.

Make sure you are aware of any restrictions with the length or height. (Window or wall dimensions should be reviewed.)

### STEP 3: Pick the size & model you require.

Select offers a range of sizes and often can provide the required heat with any one of several models. The example below illustrates the range of choices possible.

**QUESTION:** Room needs about 4500 Btu/hr on a low water temperature system. Will the SX-70-90G do the job?

**Requirement:** 4500 Btu/hr (actual heat output)

**Conditions:** Hot water temperature: 158°F  
 Room air temperature: 68°F  
 Temperature difference: 90°F

**Calculation:** Adjust the Certified Heat Output from the top table to account for the lower temperature difference between the hot water supply and the room air. (The table is based upon a difference of 108°F.)

**Example:** Certified Heat Output for  
 Model SX-70-90G: **5702 Btu/hr** (page 4)  
 Adjustment Multiplier at 90°F: **x 0.80** (2nd table)  
 Actual Heat Output: **4562 Btu/hr**

**Answer:** The SX-70-90G provides what the room needs.

**Question:** Will other models do the job?

**Answer:** YES. Any one of the models described to the left will work.