

HEAT-TIMER®

INSTALLATION AND OPERATION INSTRUCTIONS

DiGi-SPAN® *Elite Series*

HWE-SS DIGI-ELITE Hydronic Single-Stage Boiler Control

Hot Water Control with Outdoor Reset, Set Point and DHW for Hydronic Applications

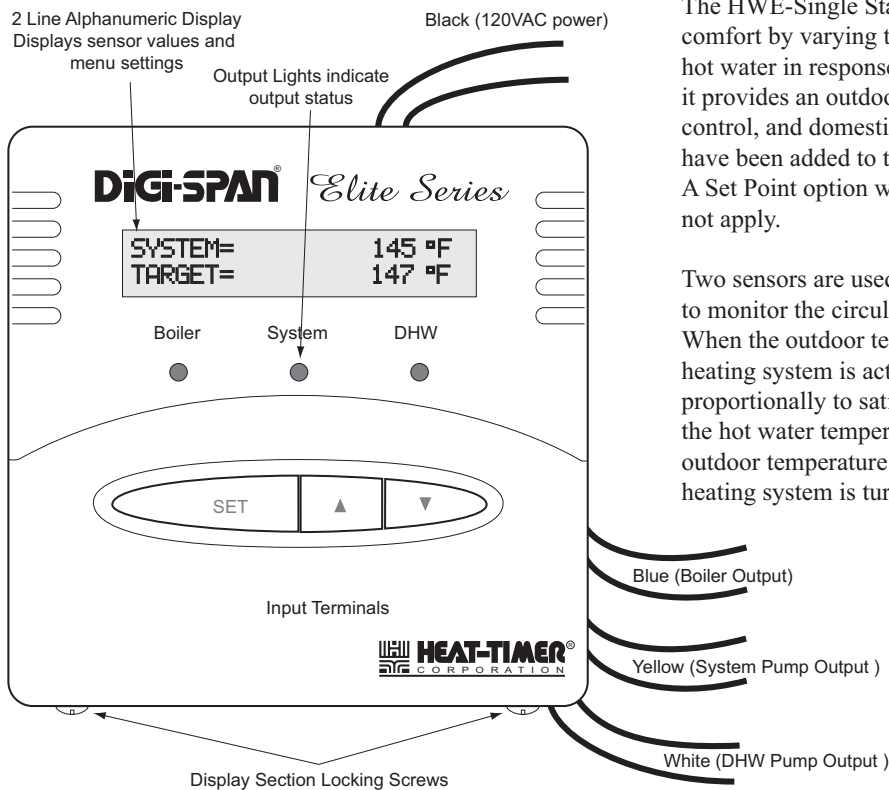

The HWE-Single Stage (HWE-SS) DIGI-SPAN Elite establishes ambient comfort by varying the temperature of the heating system's circulating hot water in response to changes in the outdoor temperature. In addition, it provides an outdoor temperature based cutoff, heating system pump control, and domestic hot water (DHW) pump control. Two new features have been added to this control including a customized reset ratio curve. A Set Point option was added for applications where outdoor reset will not apply.

Two sensors are used, one to monitor the outdoor temperature, and one to monitor the circulating hot water temperature in the heating system. When the outdoor temperature falls below outdoor cutoff setting, the heating system is activated and the hot water temperature is increased proportionally to satisfy the set point. Should it get warmer outdoors, the hot water temperature is automatically lowered by the control. If the outdoor temperature continues to rise to the outdoor cutoff setting then the heating system is turned off.

⚠ WARNING

This Heat-Timer control is strictly an operating control; it should never be used as a primary limit or safety control. All equipment must have its own certified limit and safety controls required by local codes. The installer must verify proper operation and correct any safety problems prior to the installation of this Heat-Timer control.

LIMITED ONE-YEAR WARRANTY

This Heat-Timer device was thoroughly tested for defects and workmanship before leaving our factory. We do warrant the equipment to be free of defects under normal use for a period of one year from the date of installation. Transportation charges for factory repairs must be prepaid. Damage to the Heat-Timer device or any of its components due to misuse, abuse, improper installation, or caused by power failures, fire, flood, or lightning are not covered by this warranty. The company assumes no liability for indirect or consequential damages of any nature. This Heat-Timer warranty applies only to the original purchaser/user, is not assignable or transferable, and does not cover damage to the device occurring in shipment. Any service, repairs, modifications or alterations to the unit not expressly authorized by the company will invalidate the warranty. This warranty is in lieu of all other warranties expressed or implied.

Because of many physical characteristics, and the type of radiation, i.e., baseboard or radiant, heat loss varies. In one building, a 1-degree temperature change outdoors may require a change of 1 degree in heating water temperature; for another it may require a change of 2, 3, or even 4 degrees in order to gain the desired comfort level. This is known as the Reset Ratio. The middle chart shows the wide range of Reset Ratios available for the HWE-SS.

The installer fits the HWE-SS to a specific building by adjusting the Reset Ratio curve. With a curve of 4 (2:1 reset ratio) a 2-degree change in outdoor temperature will change the circulating hot water temperature by 1 degree; at an 11 curve (1:3 reset ratio) an outdoor change of 1 degree will change the water temperature by 3 degrees. Most buildings with baseboard radiation require a curve of 6, 7, or 8. Radiant heat applications usually require a lower curve. An optional external thermostat or Set Back control input can be connected to the HWE-SS. This input can be connected to a new or existing thermostat or switch to shut the heating system down when the thermostat is satisfied. When set to Set Back mode this input will switch the heating system to a lower setting determined by the Set Back setting.

Type of Radiation in Building	Reset Ratio	Offset
Radiators (Steel & Cast Iron)	1.00 (OD) : 1.00 (SYS)	0°F
Baseboard (Finned copper tube& Cast Iron)	1.00 (OD) : 1.00 (SYS)	0°F
Radiant (High Mass/Concrete)	4.00 (OD) : 1.00 (SYS)	-10°F
Radiant (Low Mass/Joists)	2.00 (OD) : 1.00 (SYS)	-10°F
Fan Coils & Air Handlers	1.00 (OD) : 1.00 (SYS)	20°F

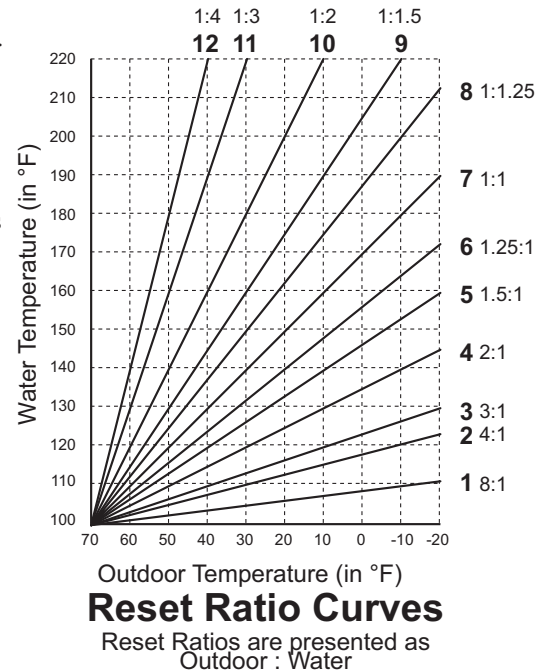

An optional domestic hot water input is provided for systems where an indirect tank provides DHW. During a DHW call, the HWE-SS will maintain a constant set point of 200°F regardless of outdoor temperature or the status of the optional external thermostat. The DHW pump will be enabled whenever there is a call for DHW. The heating system pump can be programmed to turn off during the first hour of a DHW call. This allows the DHW tank to be satisfied quickly.

Mounting the Controller

- The HWE-SS DIGI-Elite is designed to mount on a 1900 (4"x4") deep electrical box.
- If additional room is needed for wiring use the extension skirt provided in the box.
- Locate the HWE-SS in a convenient location near the unit to be controlled.
- Partially unscrew the Display Cover Mounting screws. This allows for its removal.
- Lifting the Display Section away from the base will unplug it from the Base section.
- Proceed with the power and output wiring instructions.
- Mount the HWE-SS indoors and away from excessive heat or cold.
- Use the screws provided to mount the HWE-SS to the 1900 box or the extension skirt.
- Mount Display Section back to the Base Section. Tighten the Display Cover Mounting Screws.

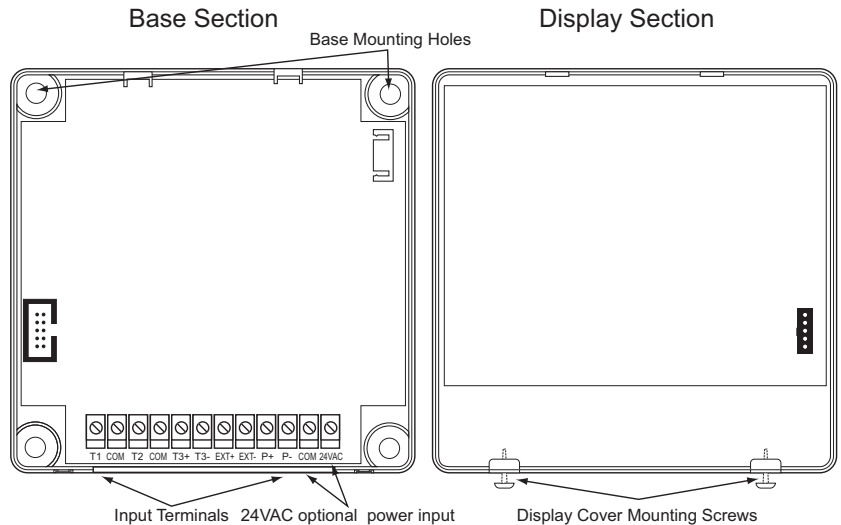

Wiring

Wiring Power Input

The HWE-SS is designed to accept **ONLY A SINGLE POWER SOURCE**. It can be wired to either 120VAC using the two Black wires or 24VAC using the right most two terminals on the terminal block on bottom of the control. Heat-Timer recommends the installation of a Surge Suppressor and a Power Switch before the Power Line connection for safety and ease of service.

⚠ WARNING
The HWE-SS can accept only one source of power: 120VAC or 24VAC. If more than one power source is applied, the unit may be damaged.

120VAC Power Wiring

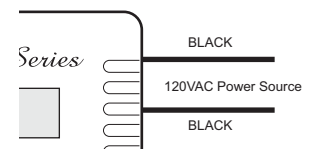

120VAC

- Attach line voltage, 120VAC, to the two Black wires extending from the back of the HWE-SS. Remember to use the power line from a different source than the equipment being controlled.
- Use wire nuts or wrap the connection with electrical tape.

24VAC

- Use a dedicated transformer with at least a 5VA output.
- Bring 24VAC to the two right most terminals on the front of the HWE-SS marked *24VAC* and *COM*.

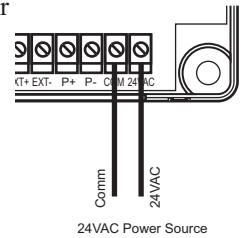
24VAC Power Wiring**Wire Colors and Output Lights**

- The HWE-SS has a three S.P.S.T. (single-pole single-throw N.O.) relays. Each output is rated at 6A.
- The HWE-SS has three lights that follow the output relays operation. When a relay energizes, its LED will turn on.
- The outputs are dry contacts only. They do not source any power.
- The two Blue wires represent Boiler Output relay and the left LED.
- The two Yellow wires represent System Output relay and the middle LED.
- The two White wires represent DHW Output relay and the right LED

Wiring Input Terminals**Heating System Sensor (HSS) Installation (T1, COM)****Locating HSS**

- Locate the Heating System sensor in the common header where it will register the output of the boiler but before any major takeoffs.
- Only use a Standard Brass Tube sensor (HT #904015-00 or equivalent).
- The sensor wires can be extended up to 500' using a shielded 2-conductor cable (Belden #8760 or equivalent). Do not ground the shield at the sensor but at the control using the COM terminal.
- Do not run sensor wires in conduit with line voltage wiring.

IMMERSION Heating System Sensor (HSS) Installation

- Install a 3/8"ID 1/2"NPT immersion well (HT #350147-00 or equivalent).
- Insert the sensor probe of the supplied sensor into the well.

Strap-On Heating System Sensor (HSS) Installation

- Strap the sensor to the pipe using metal clamps. Do not over tighten the clamp.
- Strap pipe insulation around the sensor and the pipe.

Outdoor Sensor Installation (T2, COM)

- Only use the Heat-Timer sensor included with the unit.
- Locate the sensor in the shade on the north side of the building.
- Be sure the location is away from doors, windows, exhaust fans, vents, or other heat sources.
- The sensor should be mounted approximately 10' feet above ground level.
- Mount the sensor clip base to the outside of the building. Insert the sensor in the middle and snap close the clip on the sensor.
- The sensor wires can be extended up to 500' using shielded 2-conductor cable. Do not ground the shield at the sensor but at the control using the COM terminal.
- Do not run sensor wires in conduit with line voltage wiring.

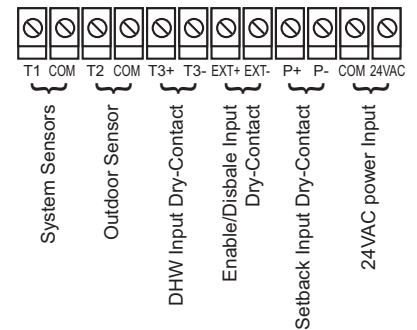
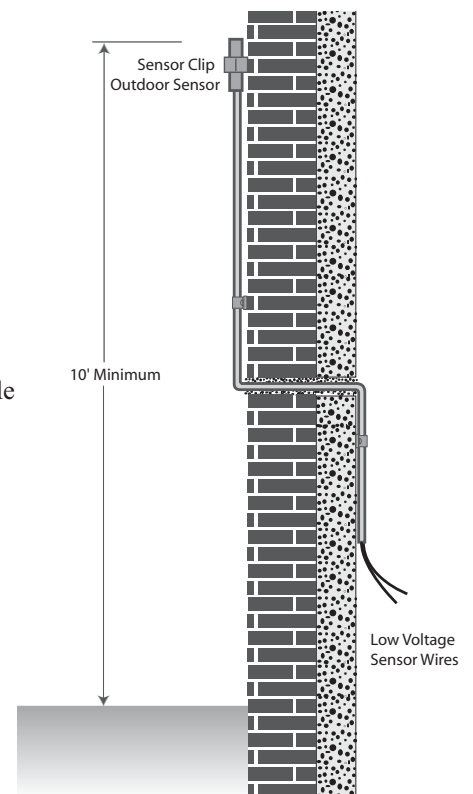
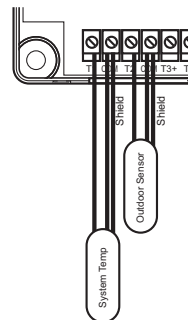
Input Terminals**Sensor Wiring****⚠ CAUTION**

Determining the proper location for the Outdoor Sensor is very important. The HWE-SS will base the heat on the outdoor temperature information it receives from this location. If the sensor is in the sun, or covered with ice, its reading will be different from the actual Outdoor temperature (OD).

Wiring the Domestic Hot Water Call DHW (T3+, T3-)

- DHW can be used to raise system Set Point to 200°F or Maximum Target temperature whichever is lower.
- DHW Call terminals are dry contact N.O. terminals.
- Wire an aquastat or other controls to provide closure on the DHW Call terminals.

DHW Call Wiring

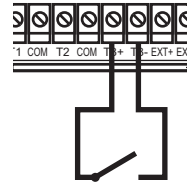

Wiring the Enable/Disable (EXT+, EXT-)

- The EXT terminals can be used to enable or disable the system by connecting it to a thermostat, external control, or a switch. It accepts dry contact input only.
- If no thermostat or control is connected to the EXT terminals, leave the jumper supplied as a contact to the terminals.
- No outputs will be active unless the EXT terminals are closed/shorted.

Enable/Disable Wiring

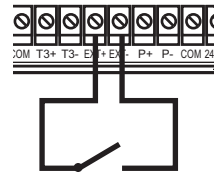

Wiring the Setback/Boost (P+, P-)

- The Setback feature can be used to provide the HWE-SS with a lower temperature Set Point when less load is required.
- A typical use for Setback is to provide less system temperature to a building during the night or on the weekends when building is not occupied, but heat is still required.
- The Setback is activated by closing/shorting the P+ and P- terminals using an external timer.

Setback/Boost Wiring

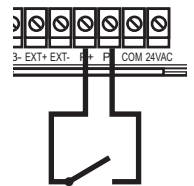

Button and Navigating Menus

The HWE-SS has three buttons.

- The SET button function varies. When the Default Screen is displayed, pressing the SET Button views the MENU. When in the Menus and settings, the SET Button accepts the selected entry or setting value.
- When in the menus, pressing the Up and Down buttons will scroll through the menu options. They can be used to change the setting of a specific function. i.e., change the Set Point, Differential, or System Trim. In addition, when in the default screen, the Up and Down buttons will display the outdoor temperature and Outdoor Cutoff.
- At the end of every operation menu there is a <Back> option that allows the user to go back one menu level. If the SET Button was held down for three seconds on the <Back> option, the display will go back to the default screen.

Startup Options

When the control is started for the first time or after a manual reset, it will initiate its operation with the Startup Menu. Moreover, the Startup menu can be accessed as an option from the operation menu. An option must be selected in each screen in the Startup Menu to move to the next level.

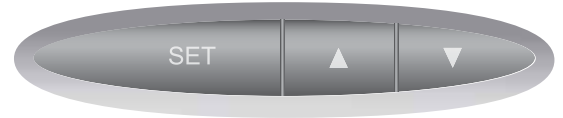

Display Unit

Options: °F, °C

Default: °F

 /<System Startup>/Display Unit

- The HWE-SS will offer two different temperature displays. If °F is selected, all temperatures will display in Fahrenheit. If °C is selected, all temperatures will display in Celsius.

```
DISPLAY UNIT:
F
C
```

Control Mode

Options: Outdoor Reset, Set Point

Default: Outdoor Reset

 /<System Startup>/Display Unit/Control Mode

- The new HWE-SS have two heating logics. Outdoor Reset; varies the system set point/target based on outdoor temperature. This selection will add several menu options, Reset Ratio, Offset, Min Water temp, Max Water temp, and Outdoor Cutoff, to allow of adjustment and fine tuning of the Reset Curve. In addition, a customized curve will be available for specialized applications.
- Set Point; Gives the installer the flexibility of selecting a fixed set point. The Outdoor Cutoff will be available if an outdoor sensor was installed.

```
CONTROL MODE:
Outdoor Reset
Set Point
```

Sensor Fault

Options: Output On, Output Off

Default: Output On

 /<System Startup>/.../Sensor Fault

- The Sensor Fault will determine the operating status of the output relays when a sensor reads Short or Open. On sensor fault the Set Point will indicate `FAULT TGT=ON` or `OFF` to indicate the condition of the output and the faulty sensor will read `OPEN` or `SHORT` to indicate the condition of the sensor.

```
SENSOR FAULT:
Output On
Output Off
```

Menus

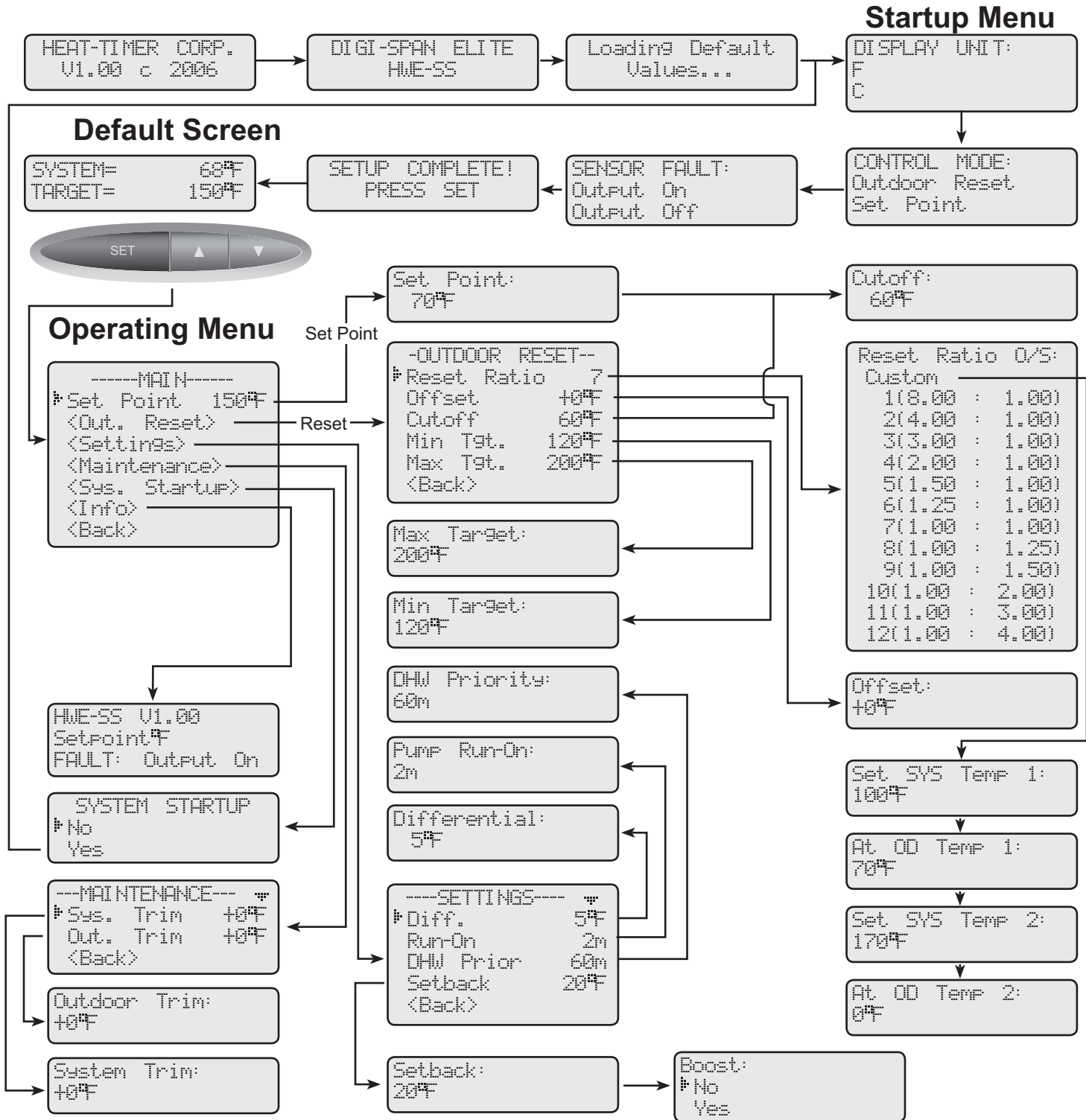

Outdoor Reset Mode

- When Output-On is selected, the HWE-SS will energize the boiler and system relay when System reads Short or Open and Outdoor is below Outdoor Cutoff. Thus, the boiler will run on its limits. However, if the Outdoor sensor fails and the Outdoor reads Short or Open, the HWE-SS will change the Target Set Point to the Max Water Temperature.
- When Output-Off is selected, the HWE-SS will turn the boiler Off when the System sensor reads Short or Open. However, when the Outdoor sensor fails, reads short or open, the HWE-SS will change the Target Set Point to be the Min Water Temperature.

Set Point Mode

- When Output On is selected, the HWE-SS will turn the boiler On when the System sensor reads Short or Open.
- When Output-Off is selected, the HWE-SS will turn boiler Off when the System sensor reads Short or Open.
- The Outdoor Sensor Short or Open status will not affect the control operation in Set Point mode.

Setting the Control to Factory Default

To Reset the HWE-SS control to its original factory defaults, power down the control. Hold down the SET and DOWN buttons while powering the control back up until the Loading Default Values screen appears. The Display will direct you to the Startup menu after the defaults are loaded to program the control.



NOTE: When resetting the control to original factory defaults all control settings will be over written and will no longer exist.

Default Display

The default display will show the current System temperature and the Target temperature. In addition, by clicking the Up or Down button, the display will show the current Outdoor temperature and the Outdoor Cutoff.

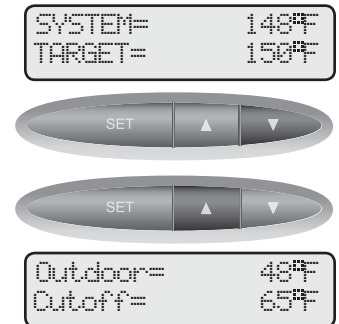

Operating Menu Options (Click SET Button)

Set Point (Available with Startup Control Mode = Set Point)

Options: From -10°F/-23°C to 230°F/110°C

Default: 70°F/21°C

 /Set Point

- The Set Point option provides the user with an adjustable fixed Target temperature to control the system. If an Outdoor Sensor was connected, the next menu option will show Outdoor Cutoff, otherwise there will be no Outdoor Cutoff option.
- The Set Point less the Differential should be set above the boiler manufacturer minimum water temperature requirements.

Set Point:
70°F 140°F

SYSTEM= 68°F
TARGET= 140°F

Outdoor Reset (Available with Startup Control Mode = Outdoor Reset)

Options: From 1(8.00°/1.00°) to 12(1.00°/4.00°), Custom

Default: 7(1.00°/1.00°)

 /<Out. Reset>/Reset Ratio

- The Reset Ratio determines how the System water temperature will vary with Outdoor temperature (OD). With any of the ratios, the colder it becomes outside, the hotter the temperature of the system water. The Ratio is measured as; Outdoor : System Water temperature.
- With a 1.00:4.00 ratio, the System water temperature will increase rapidly as the outside temperature falls, hitting the maximum water temperature of 240°F at 24°F outdoor temperature. With a 4.00 (OD):1.00 (SYS) ratio, the System water temperature (SYS) will increase slowly as the outside temperature falls.
- The Reset Ratio controls the amount of heat that enters the heating system based on the outdoor temperature. A higher numbered Reset Ratio will result in a higher Calculated water temperature. See the Reset Ratio chart on the second page. If the application has radiant heat, a lower numbered Reset Ratio curve should be selected.
- If required: **Adjust the RESET RATIO in cold weather.** If the ambient building temperatures are too cold in cold weather, move the ratio to a higher selection. That is, if 1.00 (OD):1.00 (SYS) was initially selected, change the selection to 1.00 (OD):1.25 (SYS). If the building temperatures are too warm in cold weather, move the ratio to a lower selection. That is, if 1.00 (OD):1.00 (SYS) was initially selected, change the selection to 1.25 (OD):1.00 (SYS).
- The Custom option gives the user the capability of creating a specialized Reset Ratio curve. Setting two points on the Reset Ratio chart generates the customized curve. Each point requires a System Water Temperature and an Outdoor Temperature. The line connecting the two points will be the customized reset ratio.

Reset Ratio 0/5:
Custom
1(8.00 : 1.00)
2(4.00 : 1.00)
3(3.00 : 1.00)
4(2.00 : 1.00)
5(1.50 : 1.00)
6(1.25 : 1.00)
7(1.00 : 1.00)
8(1.00 : 1.25)
9(1.00 : 1.50)
10(1.00 : 2.00)
11(1.00 : 3.00)
12(1.00 : 4.00)

Custom Outdoor Reset Curve

Options: Sys Temp 1, 2 (-10°F/21°C) to (210°F/99°C)

Default: 1(100°F/38°C), 2(171°F/77°C)

Options: Outdoor Temp 1, 2 (-10°F/-23°C) to (100°F/38°C)

Default: 1(70°F/21°C), 2(0°F/-18°C)

 /<Out. Reset>/Reset Ratio/Custom

- For situations where the provided reset ratios do not provide the perfect building heat-loss equilibrium, the customized option can be used.
- The Custom Reset Ratio is only available when Custom is selected from the Reset Ratio menu option. It provides the user with the capability of assigning two points on the reset ratio diagram and use the line that connects those two points as the customized reset ratio curve. Each of the two points will need a specific System and Outdoor Temperature to identify it on the diagram.
- To Set the first point, specify Sys Temp 1, and OD Temp 1. Then, specify Sys Temp 2, and OD Temp 2, to set the second point on the curve. The two points can be any where on the line, not necessarily at the ends.
- The chart shows an example of a customized curve 6(OD):5(SYS) that do not exist in the standard curve options. If the outdoor temperature reaches 30°F, the system target will be 145°F.
- Remember that the Min Target and Max Target apply to all reset ratios including the customized reset ratio ones.

Set Sys Temp 1:
100°F

At OD Temp 1:
70°F

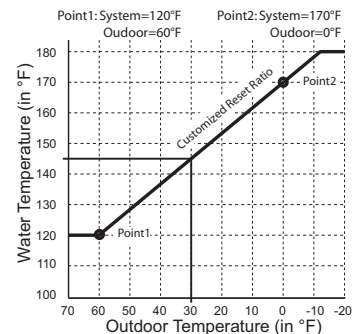

Custom Reset Ratio

Offset (Available with Startup Control Mode = Outdoor Reset)

Options: From -40°F/-22°C to +40°F/+22°C

Default: 0°F/0°C

 /<Out. Reset>/Offset

- The Offset setting lets you adjust the starting points of the Reset Ratio curves. This means that, regardless of the Outdoor temperature (OD), or the Reset Ratio that has been selected, when the Offset setting is changed, that change is directly added to or subtracted from the calculated temperature/Target. For example, if the Set Point temperature was 130°F and the Offset was changed from 0° to +10°, then the Set Point temperature would increase to 140°F

Offset:
+0°F

- If required: **Adjust the Water Offset in mild weather.** If the ambient building temperatures are too warm in the mild weather, decrease the Offset. If the ambient building temperatures are too cold in the mild weather, increase the Offset. The rule of thumb for baseboard radiation is to change the Offset 4°F for every 1°F you wish to change the building temperatures. In radiant heat applications, change the Offset 1°F or 2°F for every 1°F you wish to change the building temperature.

Outdoor Cutoff

Options: Off, 20°F/0°C - 100°F/25°C, On

**Default: 65°F
in Set Point
in Reset**

Cutoff:
60°F

 /Set Point/Cutoff

 /Set Point/<Out. Reset>/Cutoff

- In Set Point, if the outdoor sensor is installed, the Outdoor Cutoff setting screen will automatically appear after the temperature Set Point has been selected.
- The Outdoor and Cutoff temperatures can be viewed from the default screen by clicking the Up or Down buttons.
- When the outdoor temperature falls to the adjustable Outdoor Cutoff temperature, the HWE-SS will control the System Pump and Boiler relays to provide heat.
- When the outdoor temperature rises to the Outdoor Cutoff plus a 2°F differential, the HWE-SS will turn the boiler off. The System relay will remain energized for the Run-On delay then de-energize.
- The Outdoor Cutoff can be set from 20°F to 100°F. In addition, the Setting can be set to ON or OFF. If ON is selected, the System Relay will run regardless of the Outdoor temperature (OD) and the boiler will be active to hold the calculated water temperature. If OFF is selected, the System and Boiler relays will always be off.

Minimum Target (Available with Startup Control Mode = Outdoor Reset)

Options: From 70°F/21°C to 180°F/77°C

Default: 70°F/27°C

Min Target:
120°F

 /Set Point/<Out. Reset>/Min. Tgt

- The Minimum Target Temperature must be set to the boiler manufacturer's specification. The HWE-SS will calculate the Target based on the Outdoor temperature (OD), the Reset Ratio, and the Offset value. The HWE-SS will control the boiler to hold either the calculated temperature or the Minimum Target Temperature whichever is higher.
- The Minimum Target Temperature must be at least 20°F lower than the Maximum Temperature (See next setting).

Maximum Target (Available with Startup Control Mode = Outdoor Reset)

Options: From 90°F/38°C to 240°F/116°C

Default: 240°F/116°C

Max Target:
200°F

 /Set Point/<Out. Reset>/Max. Tgt

- This is the highest temperature heating water the HWE-SS will circulate through the heating system.
- When using a radiation system, it should be set according to the tubing or floor manufacturer's specification.
- The Maximum Temperature must be at least 20°F higher than the Minimum Temperature.

Differential

Options: From 1°F/1°C to 20°F/11°C

Default: 5°F/3°C

Differential:
5°F

 /Settings>/Diff.

- The Differential controls boiler cycling. When there is a call for heat, the boiler will be activated until the Calculated temperature is reached. The boiler will then turn off and stay off until the system water temperature falls through the number of degrees set by the Differential.
- A smaller Differential setting will normally result in tighter control of the set point but will tend to increase the frequency of fluctuation in the system. Larger Differential values will reduce boiler short cycling, but the system will be allowed to vary further from the target value.

Run-On

Options: From 0 min to 60 min

Default: 2 min

Func Run-On:
2m

 /Settings>/Run On

- The SYS relay will energize whenever the Outdoor temperature is below the Outdoor Cutoff. When the Outdoor temperature increases 2°F above the Outdoor Cutoff after the boiler relay has de-energized, the SYS relay will stay on for a period set by the System Run-On. This allows the Pump to dissipate the residual heat within the boilers back into the system.
- A common use for the System Run-On is to control a system pump in a heating system. The extra time helps transfer the heat from the boilers to the heating system.
- The System Run-On time should be set based on the size and type of the boilers and pumps. In general, a boiler with low water content and high horsepower will need a longer System Run-On than a boiler with the same horsepower and more water content. (Refer to boiler manufacturer recommendation).
- When DHW Priority is active while the TSTAT is open or the outdoor temperature is above the Outdoor Cutoff, a DHW call will energize only the DHW relay. When the DHW call expires, the DHW will run for the Run-On period then de-energize.

Domestic Hot Water (DHW) Priority

Options: NO and From 1 min to 120 min

Default: NO

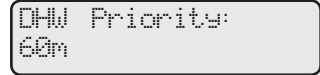

SET /Settings>/DHW Prior.

- The DHW Priority, value set to other than NO, provides the user with an adjustable DHW priority timer for the domestic hot water call. That is, initiating a DHW call, closing/shorting the T3+ and T3- terminals, will de-energize the system relay for the period set by the DHW Priority. However, the DHW relay will remain energized for as long as the T3+ and T3- terminals are closed/shorted. This will take place whenever the control is in heating mode, Outdoor temperature is below Outdoor Cutoff, or the TSTAT terminals are closed/shorted.
- If NO was selected as the option for the DHW Priority, a DHW call will energize both relays, System and DHW even when Shutdown is activated.

Setback

Options: From 0°F/0°C to 80°F/44°C

Default: 11°F/6°C

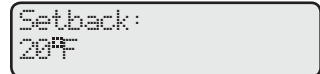

SET /Settings>/Setback.

- The Setback feature can be used to provide the HWE-SS with a lower temperature Set Point when less load is required.
- The lower Set Point will appear on the main display indicating this condition.
- In other words, if the calculated temperature is 160°F and the Setback is 20°F, then, when in Setback, the HWE-SS will hold a Set Point of 140°F.
- A typical use for Setback is to provide less system temperature to a building during the night or on the weekends when building is not occupied, but heat is still required.
- The Setback is activated by closing/shorting the P+ and P- terminals using an external timer.

Setback/Boost Wiring

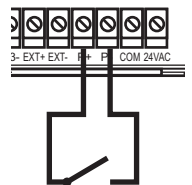

Boost

Options: Yes, No

Default: No



SET /Settings>/Setback/Boost.

- The morning Boost is designed to return the building to comfortable ambient temperatures after the cooler Night (Setback) period. The HWE-SS will accomplish this by running elevated water temperatures (will add Setback setting to calculated water temperature) for 30 minutes after the opening of the setback terminals P+ and P-. That is, if the normal set point at a specific outdoor was 145°F and the Setback setting was 20°F, the boost will raise the system calculated temperature to 165°F for 30 minutes after the setback.

System and Outdoor Trim

Options: From -20°F/-11°C to +20°F/+11°C

Default: 11°F/6°C

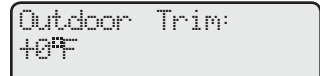
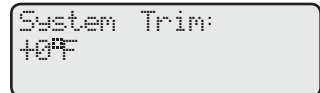

SET /<Maintenance>/Sys. Trm or Out. Trim

- The System and Outdoor Trim values adjust the System Sensor and Outdoor Sensor readings using positive or negative values. They allow you to calibrate the sensor by the number of units selected.

Enable/Disable Input

- The HWE-SS will operate in heating modes only if the EXT- and EXT+ terminals are shorted. If no external equipment or switch is connected to these terminals, leave the factory installed jumper.
- When the terminals are OPEN, the Target will display TSTAT OPEN.
- Even if the EXT terminals are open, a call for DHW will energize the output relays based on the DHW Priority configuration.
- The Enable /Disable terminals can be used as a Summer/Winter switch when connected to an external switch.

Enable/Disable Wiring

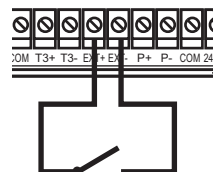

NOTE: On a sensor fault while the Enable/Disable terminals are open, the control will follow the Enable /Disable state regardless of the sensor fault condition.

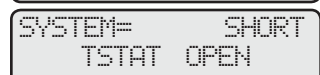
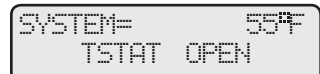

Troubleshoot

No Display or LED Lights

Check the power to the HWE-SS. The HWE-SS requires 120VAC power to the Black wires or 24VAC to the right most terminals. Turn the power off and back on to restore the display. If unsuccessful, make sure the Display Cover of the control is securely mounted to the Base.

System or Outdoor Reads OPEN or SHORT

If Open, check that the wires from the sensor are continuous to the HWE-SS. If Short, remove the wires from the input terminals. The display should change to read OPEN. If it doesn't, the HWE-SS may be damaged.

System or Outdoor Reads an Incorrect Temperature

Remove the wires from the input terminals. The display should change to read OPEN. If it doesn't, the HWE-SS may be damaged. Take an ohm reading across the detached sensor wires. The ohm reading should correspond to the Temperature Sensor Chart. If it doesn't, the sensor may be damaged.

No Heat - All LEDs are OFF

Check the outdoor temperature and Outdoor Cutoff readings. If the outdoor temperature is above the Outdoor Cutoff, the HWE-SS will not give heat. If the display shows TSTAT OPEN then, check the EXT terminals. If the EXT terminals are not jumped together, the HWE-SS will not give heat.

No Heat - All LEDs are ON

Remove any connections to the Yellow wires for the Heating System Pump. Test for continuity across the pair of Yellow wires. If the wires are continuous, the HWE-SS is calling for the Heating System Pump to run. Check the pump to determine why it is not circulating.

No Heat - System Pump LED ON

Check that the displayed System water temperature is below the Target water temperature minus the Differential. If not, wait until the System temperature falls, and then the boiler should fire. Otherwise, remove all connections from the Blue pair of wires for boiler control. Check for continuity across the pair of Blue wires. If the wires are continuous, the HWE-SS is calling for the boiler to run. Check the boiler to determine why it is not firing.

No Heat - Boiler LED ON

The HWE-SS is registering a call for DHW. If the DHW Priority is set to a value other than 0, the Heating System Pump will not run during the priority period of a DHW call. Generally the DHW will be satisfied before a drop in ambient temperature is noticeable. If the DHW load is large, change the Priority setting to 0, this will allow the Heating System Pump to circulate heating water while the DHW tank is being satisfied.

Temperature Sensor Chart

Cold DHW - Boiler LED ON

Check if the System water temperature display is approximately 200°F or above Max. Target. If it is cooler, remove any connections across the Blue pair of boiler wires. If the Blue wires are continuous, then the HWE-SS is calling for the boiler to run. Check the boiler to determine why it is not firing. If the System Water temperature is hot, remove any connections to the pair of White wires for the DHW pump. Check for continuity across the pair of White wires. If the wires are continuous, the HWE-SS is calling for the DHW pump to circulate. Check the pump to determine why it is not circulating.

TEMPERATURE (in Degrees °F)	Value (in Ohms)	TEMPERATURE (in Degrees °F)	Value (in Ohms)
-30	117720	100	2914
-20	82823	110	2332
-10	59076	120	1879
0	42683	130	1524
10	31215	140	1243
20	23089	150	1021
25	19939	160	842
30	17264	170	699
35	14985	180	583
40	13040	190	489
45	11374	200	412
50	9944	210	349
55	8714	220	297
60	7653	230	253
70	5941	240	217
80	4649	250	187
90	3667		

HWE-SS Plumbing and Wiring Diagrams

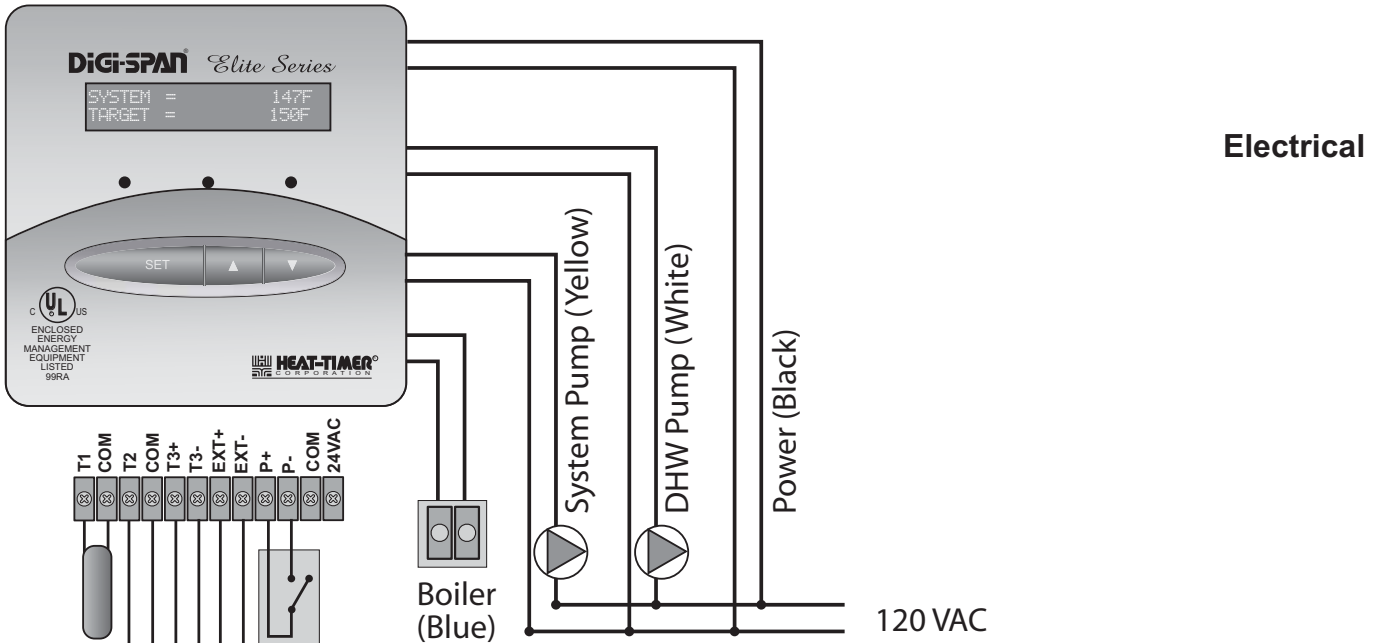

NOTE: The diagrams are conceptual only. Heat-Timer is aware that each installation is unique, however, the diagrams in this document are to represent control operation concept only. It is the installer responsibility to comply with local codes and to install safety controls.

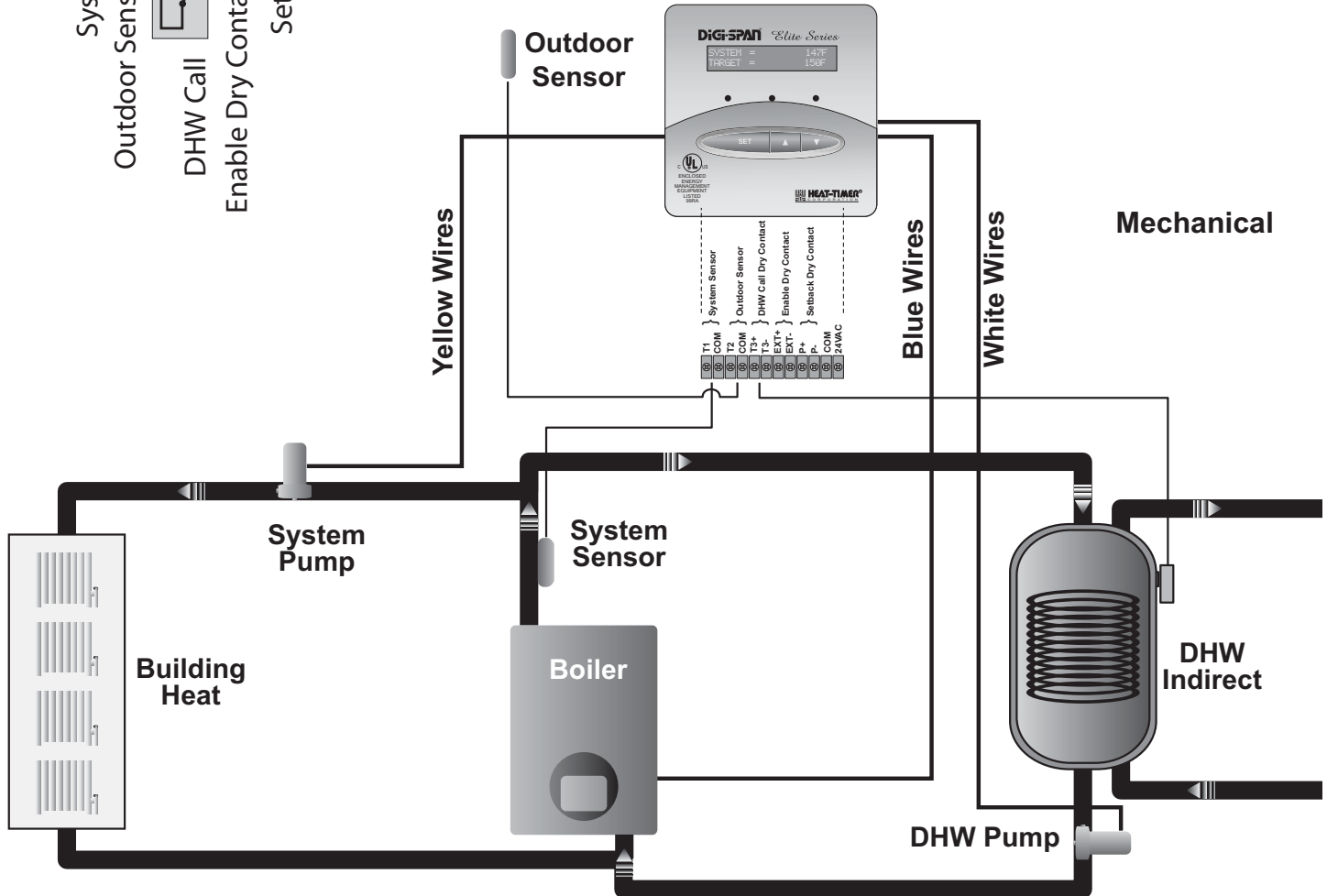

Specifications

Voltage Input:	120 VAC 60 Hz(2 Black wires) /24VAC 60 Hz (24VAc terminals) (Only One Power Source)
Power Consumption:	3 VA Max
Operating Temperature:	20°F to 120°F
Operating Humidity:	20% to 80%
Dimensions:	4"W x 4"H x 2½"
Weight:	1 pound
Display:	Back Lite 2 Line Alphanumeric LCD Display
Display Units:	Fahrenheit (°F) and Celsius (°C)
Outputs:	3 S.P.S.T (Blue = Boiler.), (Yellow = System Pump.), (White = DHW pump)
Output Relay Ratings:	1 Amp inductive, 6Amp resistive at 120 VAC 60 Hz
Control Modes:	Outdoor Reset, Set Point
Reset Ratios:	12 ranging from 8:1 to 1:4 (Outdoor: System), and Custom
Set Point:	from -10°F (-23°C) to 230°F (110°C)
Pump Run-On:	from 0 to 60 minutes
DHW Priority Timer Options:	0=No Priority, 1- 120 Minutes
Setback:	from 0°F (0°C) to 80°F (44°C)
Boost:	.Yes, No
Sensor Fault Operating Options:	Output On or Output Off
Temperature Ranges:	from -10°F (-23°C) to 230°F (110°C)
LED:	3 representing the Output relays (Left=Boiler, Middle=System Pump, Right=DHW Pump)
Buttons:	3 (Set, Up, Down)
Enable/Disable:	Terminals EXT+, EXT-