

# "BASIC" MECHANICAL PIPING DIAGRAM

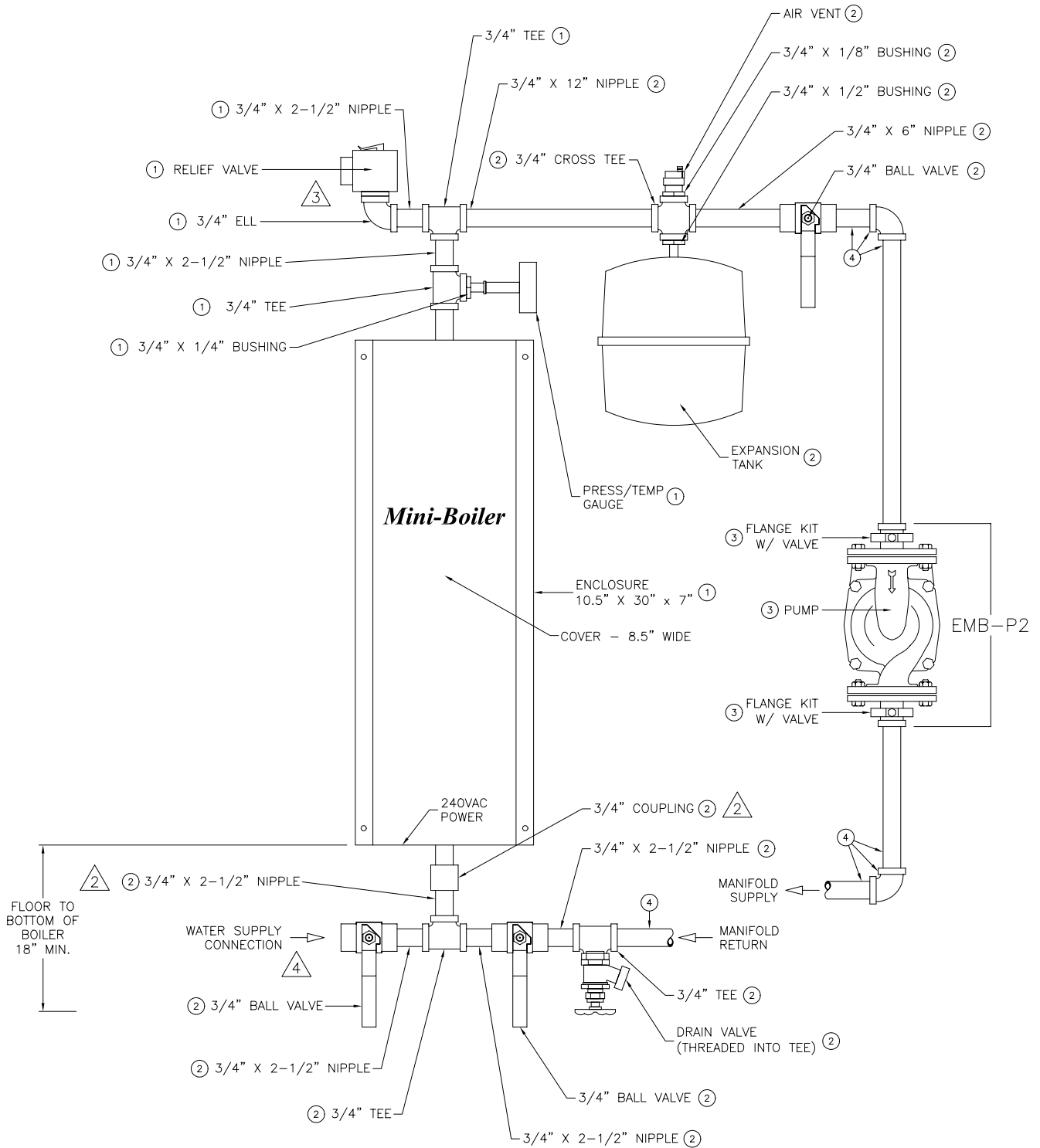

## LEGEND

- ① COMPONENTS INCLUDED WITH EMB-1, EMB-2, EMB-4, EMB-5 AND EMB-9
- ② COMPONENTS INCLUDED WITH EMB-BK KIT
- ③ COMPONENTS INCLUDED WITH EMB-P2 (PUMP) KIT
- ④ COMPONENTS NOT INCLUDED, SHOWN FOR REFERENCE ONLY

## NOTES:

1. INSTALLATION KIT (PART NUMBER EMB-BK) INCLUDES ALL PIPING PARTS (LESS PUMP & FLANGES) EXTERNAL TO THE 9.5" x 30" x 7" ENCLOSURE.
2. 3/4" COUPLING AND 2-1/2" X 3/4" NIPPLE VERY IMPORTANT. BOTTOM KNOCKOUT ACCESS REQUIRED FOR ELECTRICIAN.
3. ADD NECESSARY DRAIN PIPE.
4. SEE INSTRUCTION MANUAL FOR PRESSURE CONCERNS AND MAY NEED BACKFLOW PREVENTER.
5. SLAB STAT, ORDER NUMBER: ES-24-SRO.



# "PREFERRED" MECHANICAL PIPING DIAGRAM

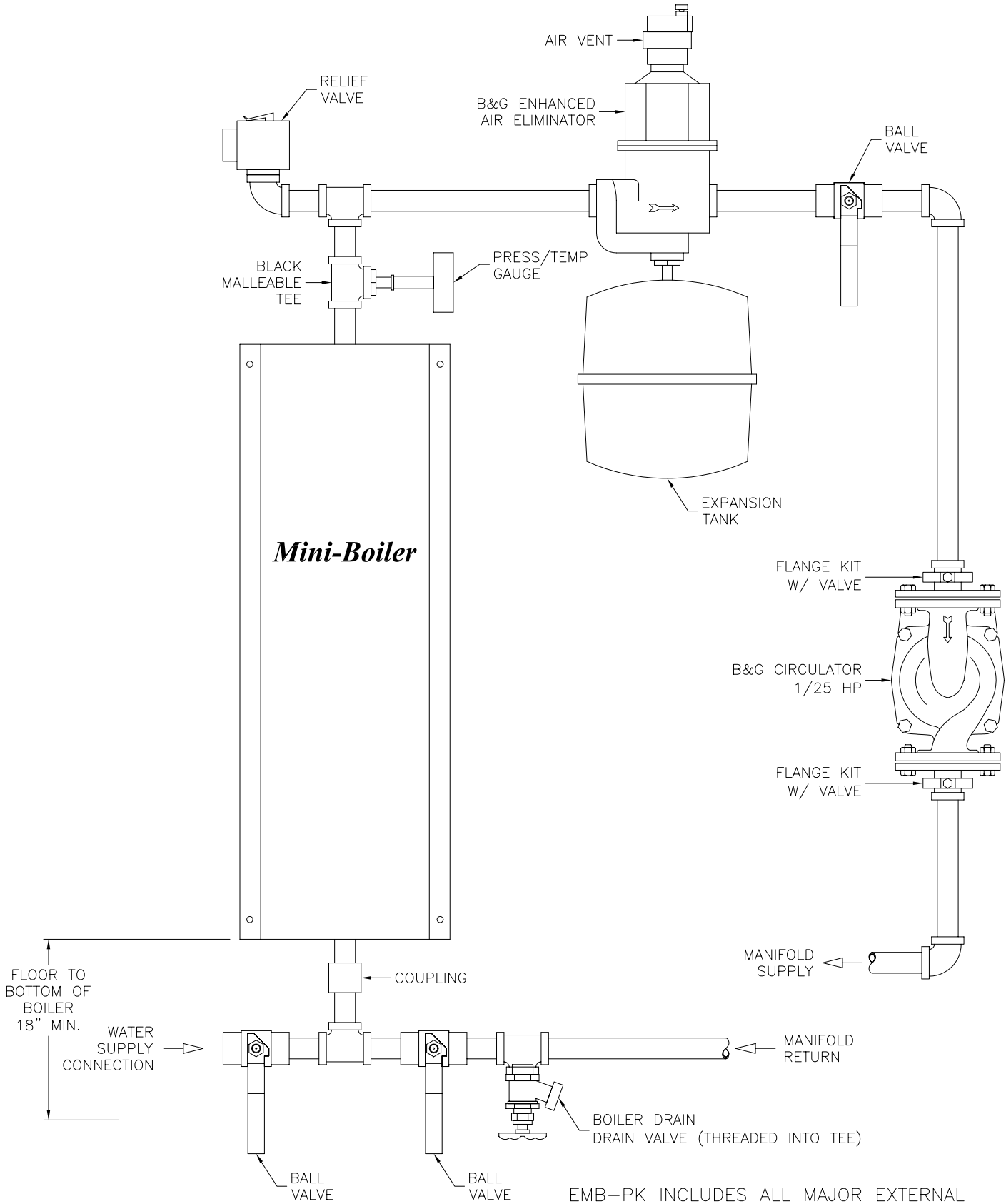

EMB-PK INCLUDES ALL MAJOR EXTERNAL PARTS SHOWN, EXCLUDING PUMP.