

Zone Controller

TS Series Boiler

EB-ZTA-1 & EB-ZEA-1

Application

This model is designed and equipped to handle various combinations of zone pumps, various zone valve types, actuators, etc. The one control board has wiring arrangements for all zone operating devices.

A major feature is built-in automatic stage shedding based upon the capacity of each active zone. This compensates for any mixture of large and small zones. **Note: Capacity and SIZE dial switches must be set during installation.**

Convenience of an attractive wiring center, all connections at easily accessed terminal blocks, LED's, and simplified zone system installation are also basic to this model.

Special automatic or built-in **shift** to higher water temperature for **priority** zone 1. In many combination temperature installations this feature eliminates mixing valve or injection pump temperature control.

Features

Dual Control Temperature, Priority Zone

Digital or Standard Thermostat Compatible

Compatible with zone pumps, zone valves (4, 3, 2 wire devices), actuators, etc.

Fuse Protected, Control Board and Zone Valve Connections

Nine LED Onboard Lights, each Stat and Zone Valve End Switch, and basic power

Control Board only, installed within TS Boiler

Remote Data Communication to Boiler Control Board

Configuration

Electro Industries **EB-S**, **EB-WO**, or **EB-WA** model series boilers.

- This is a control board only, mounts within the boiler cabinet.
- Installation and hookup drawing between boards (BH020, page 1) shows this unit within the boiler cabinet.

Model **EB-C-***** or **EB-M-***** do not have space within the enclosure, zone controller EB-ZEA-1 is the same board with an enclosure for external mounting and its own 24-volt transformer.

- The self-contained transformer will require external power at the primary. There are various voltage taps for 120, 208, or 240.
- Drawing BH020, page 2 represents this hookup which only includes a wire between the two commons and the W-OUT wire. The 4-wire remote bus cable is required in all installations.

Also all TS Boiler software program chips must be version 5.3*, 6.2*, and 3.3* or higher.

Applications Requiring More Than 4 Active Zone Inputs

Order and add a second controller (referred to as slave) to this system. Model EB-ZEA-2 is mounted external to the boiler cabinet, has its own 24-volt transformer, and is interconnected to this controller board. This combination now allows up to 8 active inputs.

Drawings: **BH019**
BH020



ELECTRO INDUSTRIES, INC.

2150 West River Street, PO Box 538, Monticello, MN 55362

763.295.4138 • 800.922.4138 • fax 763.295.4434

sales@electromn.com • www.electromn.com

Unique Zone Controller Dual Temp. Feature

The switch-able priority has the normal function of allowing zone 1 to override or hold off all other zones so that the boiler can produce full capacity energy for zone 1 requirement. **In addition**, this zone controller with the TS boiler also automatically raises the outlet temperature for low mass, high supply temperature zone.

- Example – zone #1-baseboard fin tube, air handler coil, staple-up, etc.

With priority switch on and as factory shipped, zone 1 is always high temperature (150°) requirement. The remaining zones, typically connected to radiant floor tubing, operate at the outlet temperature setup by the front panel red knob. On the inside boiler control board there is a plug-in header which can be field changed to increase supply temperature to 180°.

- Change the 150° operating point to 180° - remove the peg jumper header marked “J7”

There may be applications where priority is desired but not dual temperature. In this case there is a peg jumper on the zone control board.

- Priority without high temperature shift – remove the peg jumper header next to “Dual Temp”

Installation/Hookup – Controller - Internal

Reference: Drawing BH020, page 1

1. Since this zone controller board is installed within the Electro-Boiler TS Series cabinet, it is assumed you have EB-W* Series.
2. Depending upon the factory order, this control board may have been installed prior to shipment.
3. This control board mounts on the inside chassis, above the element power relays. Mount horizontally, roomstat terminal blocks are at the top.
4. Connect a 4-wire thermostat cable between the terminal block marked REMOTE and the same terminal block on the boiler control board. This must be point to point, V+ to V+, etc.
5. This zone controller board 24V source is tapped from Electro-Boiler transformer. Parallel wire 24VAC tab and COM tab. **WARNING:** If the yellow and gray wires from the EB-Z**-1 are crossed when connected to the control board and power is turned on, damage will result to the boiler transformer, EB-Z**-1, and boiler control board.
6. The zone controller board turns on the boiler with the W OUT tab. On the right side of the zone board route a wire from the W OUT to the boiler W stat terminal. The above COM wire is the return for this W OUT.

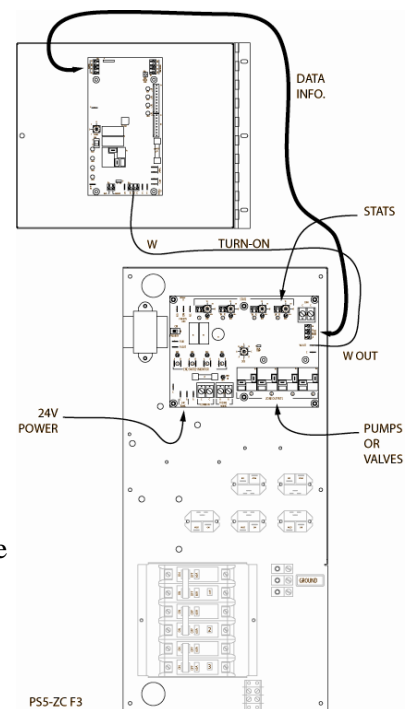

Installation/Hookup – Controller – External

Reference: Drawing BH020, page 2

1. This model has its own enclosure with 40VA transformer.
2. The transformer will need an appropriate primary source. Decal on the transformer shows 120/208/240 wire colors.
3. A common connection or wire is required between a main boiler C tab and the C tab on the zone controller board.
4. Connect a 4-wire thermostat cable between the terminal block marked REMOTE and the same terminal block on the boiler control board. This must be point to point, V+ to V+, etc.

Installation/Hookup – Thermostat

Reference: Drawing BH020, pages 3 and 4

1. Connect slab stat or temperature sensing **thermostat** to the top terminal block “R and W”. If using Electro-Stat, a common is required at each Electro-Stat. Common is available at the top right terminal block. Drawing shows typical hookups for various thermostats. Connect per your selected thermostat.
2. If using priority high temperature feature, zone 1 and connected stat 1 must be the high temperature zone.

Installation/Hookup – Zoning Devices

Zone Pumps – Drawing BH019, page 1

1. The 120-volt source for the zone pumps is tied to one tab of each of the zone output relays.
2. The other tab on the relay goes to each zone pump.
3. The common of each zone pump is tied together back to neutral.
4. Since zone pumps do not have an end switch, there must be a jumper across each end switch monitor tab. Simply make up four short wires with a ¼ female tab connector on each end and install A to B as shown.

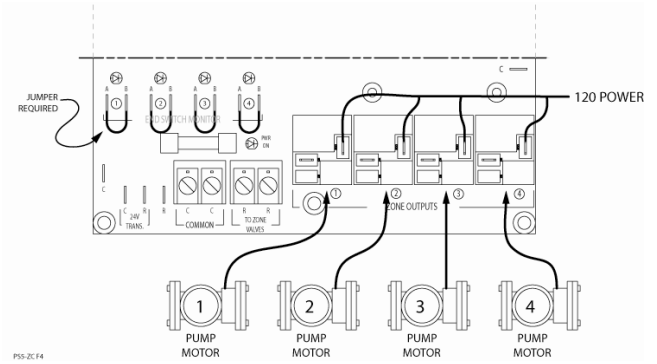

Zone Valve, 4-Wire – Drawing BH019, page 4

1. Connect a circuit board terminal C wire to a tab terminal on each zone output relay.
2. Connect the other relay tab terminal to one wire of the zone valve motor.
3. Take the second wire from the zone valve motor to the “R” terminal block.
4. Each zone valve end switch wires are extended and connected to the END SWITCH MONITOR tabs.

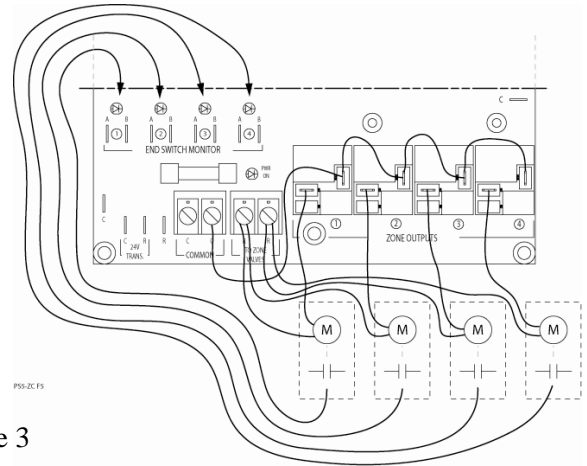

Zone Actuators or 2-Wire Zone Valves – Drawing BH019, page 3

1. Zone valve solenoid or motors are wired identical to above.
2. Since 2-wire device does not have end switch, the END SWITCH MONITOR tabs must be jumpered as stated above under Zone Pumps.

3-Wire Zone Valves – Drawing BH019, page 5

1. With these devices internal to the zone valve the 24-volt input wire is common to one side of the end switch.
2. Connect a circuit board terminal C wire to a tab terminal on each zone output relay.
3. Connect the other relay tab terminal to one wire of the zone valve motor.
4. The other point of the end switch (typically terminal 3) is connected to the “B” tab of the end switch monitor.

Taco Self-Contained Pumps – Drawing BH019, page 2

1. Each of the pump circuit boards requires a 120 source.
2. The priority switch on the pump board must be in “non-priority”.
3. The stat terminals for the zone pump board are connected to a relay contact on the zone board.
4. The end switch terminals on the pump circuit board are connected to an appropriate end switch monitor A and B point.

Zone Pumps with Zone 4 going to a sub-branch of 4 additional valves

1. A second controller, EB-ZEA-2, is also required for the second subset of 4.
2. The pump associated with the second zone board (having zone valves) must be operated from #4 relay on the first board (primary).
3. The pumps for zones 1, 2, and 3 are connected and wired same as the above first section.

Boiler Circulator/Pump Information

The pump connection and operation to the main boiler depends upon the zone arrangement detailed in the previous section.

1. If it is zone pumps, you do not use or wire to the zone pump terminal block in the boiler itself.
2. If it is zone valves, the single pump will receive its contact closure from the terminal block within the boiler itself.

Thermostat Heat Anticipator Setting

The two thermostat screw terminal contacts match to fixed 650-ohm load. Set the anticipator to 0.2 or less.

Setup – Zone Sizes and Boiler Stage Sizes

On the zone valve controller board there are five dial switches. **Four** relate to **each zone** and one relates to boiler **size** information. If all four zones are not present or used, set the unused dials to 0.

From building design information and/or zone capacity calculations, installer must know the approximate BTUH capacity of each zone. Dial in this capacity for each zone:

- 0 = 15,000 BTUH
- 1 = 30,000 BTUH
- 2 = 45,000 BTUH
- 3 = 60,000 BTUH

The 5th dial switch must be set to the boiler **size**.

Model	Boiler Size	Size Dial Switch Position	Zone Dial Switch Multiplier ²
EB-*-10	10 kW	A	1
EB-*-13	13 kW	A	1
EB-*-15	15 kW	B	1
EB-*-18	18 kW	B	1
EB-*-20	20 kW	C	1
EB-*-23	22.5 kW	C	1
EB-*-27	27 kW	D	1
EB-C-27-*	27 kW	D	1
EB-C-40-*	40.5 kW	D	1
EB-C-31 & -36	31 or 36 kW	D	2
EB-C-18-48	18 kW	C	1.4
EB-C-36-48	36 kW	D	1.4
EB-C-54-48	54 kW	D	1.4

Notes

1. When in priority, all stages of the boiler come on and the above is bypassed.
2. When using this to switch the EB-C-*** boiler, the Btu settings next to the stat input dial switch may need to relate a different value. This column represents a multiplier times the dial switch setting Btu value. Example – for the 54 kW boiler the 0 position dial switch (15,000) now really represents $15,000 \times 1.4 = 21,000$.
3. Position E is not used. F, G, and H relate to multiple boilers.

Multiple Boilers, Using EB-C-STG5 Staging Relay

It is assumed the zoning arrangement has one or two small zones which can be handled by the first boiler and primarily large zones which will require stepping up to the next boilers. There are three boiler **size** settings and the first decision relates to proper zone connection and discerning the large zones wired into this zone controller. In this case the term “large zone” would mean the capacity of the complete boiler system (multi-boilers) is required to satisfy the capacity of “large” zone(s). Set the large zone dial switch to position 3, but in this position it is assumed more than the **master** boiler is required and all element stages will be activated,

based upon boiler outlet temperature sensing. For zone 1 and including a slave zone controller (-2 model), the dial setting needs to be related to the zone Btu capacity which is communicated and related back to element stage zoning for the first or master boiler.

- “F” – one large zone which needs to be tied into #4. Zones 1, 2, and 3 require setting the dial switch representing the Btu’s for this zone and can be related to the Btu numbers in the above chart.
- “G” – two large zones which need to be tied into #3 and #4. Zones 1 and 2 require setting the dial switch representing the Btu’s for each zone and can be related to the Btu numbers in the above chart.
- “H” – three large zones which need to be tied into #2, #3, and #4. Zone 1 requires setting the dial switch representing the Btu’s for each zone and can be related to the Btu numbers in the above chart.

Priority High Temperature Zone Function

Application – one zone requires higher supply temperature (typically low mass) and the remaining zones require low temperature (typically high mass).

Note: When zone 1 is activated with the priority switch on, the zone size dial setting for zone 1 is bypassed. In this arrangement, the zone control board allows the master boiler to regulate the staging and temperature requirements needed for zone 1. In other words, it is possible that the full capacity of the boiler or boilers will be on during the priority call.

1. The stat relating to priority **must be stats 1, R and W**.
2. The zone valve or pump relating to priority must be zone 1.
3. Priority switch must be in “ON” position.
4. With priority on and stat 1 “W” terminal at 24 volts, zone output relays 2, 3, and 4 are interrupted (zone valve motor does not activate).
5. The LED associated with the stat inputs is active and shows the stat status. The LED’s associated with the zone monitor will be off because the zone valve end switch (terminals A and B) is open.
Note: If there is no end switch and you are simply jumpering terminals A and B, the zone valve LED’s will give a false indication.
6. With stat 1 input and priority switch on, the boiler outlet temperature will regulate at one of two preset values: 150° F or 180° F. At the boiler main control board (hinged door) approximate center left side is a 2-pin jumper associated with the markings **SW1**.
 - a. 150° F – as factory shipped, the 2-pin header is installed as a jumper.
 - b. 180° F – remove the 2-pin shorting block header.
Note: If your installation does not require high temperature during priority, remove the 2-pin shorting block header labeled “Dual Temp”.
7. “Priority AUX” is a dry contact terminal block, which is a direct function of zone 1 end switch terminal (3 to 4).
8. After a 60-minute timeout, zones 2, 3, and 4 are released to respond to stat inputs. Zone 1 could remain active, but any other zones that are calling will respond as if the system is not in priority. Zone 1 also returns to a normal stat input. The supply temperature drops to front panel setting. An interruption of zone 1 “W” terminal or turning priority switch off/on resets this 60-minute timer.

Note: All elements (stage LED’s) may be off until supply temperature drops to front panel red knob set point.

Option: There have been several field requests for priority timeout to be greater than the standard 60 minutes. A change-out chip (UIC9764) with Ver 3.32 (R-116) can be used for 4-hour priority timeout.

Monitor LED’s

- Power on – green LED represents good fuse and 24-volt transformer source.
- Slab stat or temperature sensing thermostat inputs – illuminates with voltage at “W”.
- Zone valve – illuminates with appropriate stat heat call **and** an end switch contact between A and B.

Fuse

Protects this board and all external field connections/wiring. Replace with 2-amp, fast blow, AGC2.

Staging

The actual boiler stages are controlled within the boiler main board from the information calculated within the zone controller board and communicated to the boiler main board. The sum of the various zone input dial switches determines which boiler stages are active. The zone dial switches calculation has priority over the temperature sensing. However, if the temperature sensing indicates the vessel is suddenly rising, it will override and turn off stages.

The number of stages will depend upon capacity calculations from the settings. The capacity dial switch position has an assigned value:

15,000 Btu/h = 1
30,000 Btu/h = 2
45,000 Btu/h = 3
60,000 Btu/h = 4

As the zone stats turn on and off these are added for a boiler staging sum. This sum value controls stage per:

1 = Stage 1
2 = Stage 2
3 = Stage 3
4 = Stage 4

There is an approximate 6 to 60-second delay between stage-up turn on and less than 4-second delay on stage-down.

Note: See previous section on sizes as they relate to EB-C-** commercial and special paragraph for multi-boilers.

Operational Test

1. Thermostat and zone reaction – as each thermostat is turned up there should be an appropriate reaction from the zone pump/valve/actuator connected to the correct zone number and zone thermostat. LED's for stat input and amber LED's for "end switch monitor" should follow their appropriate inputs.
 - If you do not observe end switch monitor LED's, there is a problem with the end switch monitor wires associated with the A and B tabs. Recheck the hookups on drawing BH019 or the end switch itself within your particular zone device.
2. Boiler, call for heat LED – with a single zone turn-on, the boiler should be activated and show a heat call.
 - If not, check the "C" or common between this zone board and the boiler or the "W-OUT" wire going to the boiler W.
3. Digital communication to the main boiler board – there are two suggested checkout methods. The A method can only apply if the program control chip within the main boiler is 5.33 (or higher) or 6.22 (or higher).
 - A – After each power-up the internal system verifies proper data communication between the zone controller and the boiler main board. This can be verified by observing the EL ON (yellow) front panel LED.
 1. Turn off the boiler CB1 (basically removing power from the internal 24-volt transformer).
 2. Watching the front panel EL ON (yellow) LED, turn on the circuit breaker.
 3. Approximately 5 to 8 seconds later this EL ON LED blinks for approximately 15 seconds.
 4. This is a verification of proper hookup and functioning of both main board and zone controller board.
 5. If the blink function was not correct as detailed above, recheck the wiring between the two REMOTE terminal blocks, 24-volt power at the Zone Controller board,

proper 24-volt wiring polarity with C going to C, etc. Also make sure it is a first 4 or master board. Master board has priority switch, slave does not.

Note – If the application is more than 4 zones and there also may be a second 4 (slave) Zone Controller, the action of these monitor LED's is completely different with two boards hooked up. See companion installation manual BI009 for appropriate power-up procedure.

B – Activate several zone thermostats and wait for all four stage lights (main circuit board, inside) to come on within the main boiler. Turn off or decrease setting of all zone thermostats **except** the one smallest zone. Within 15 seconds, the stage lights on the main boiler board shall drop out, showing only the number of stages relating to the value dial switch setup for the smallest zone (example – dial switch set on 0 or 15,000 Btu equals stage 1 only).

4. Priority (if using and on) – do not activate stage 1, activate one or two other stages and observe proper action within the zone device (not LED, the zone device itself). Now activate zone 1 verify the other zone devices drop out. The main boiler will also stage up for full output.
 - PC software or updated Analyzer (WF-ANZ*) can be used to verify the step up in temperature if dual temp feature is used.

Troubleshooting

1. The LED's on this zone control board should provide adequate indication of inputs and outputs. The LED's at the end switch tabs represent the closure of end switch.
2. See previous description on priority and dual temp arrangement.
3. If troubleshooting the complete boiler system indicates the desire to unplug the remote bus connector to verify whether or not the zone controller is interacting with the main boiler board, the main boiler must be reset (power off and on) whenever the remote bus cable is unplugged or plugged back in.

EB-ZTA-1 / EB-ZEA-1

2 - 4 ZONE PUMPS



NO PUMP CONNECTION AT BOILER PUMP TB

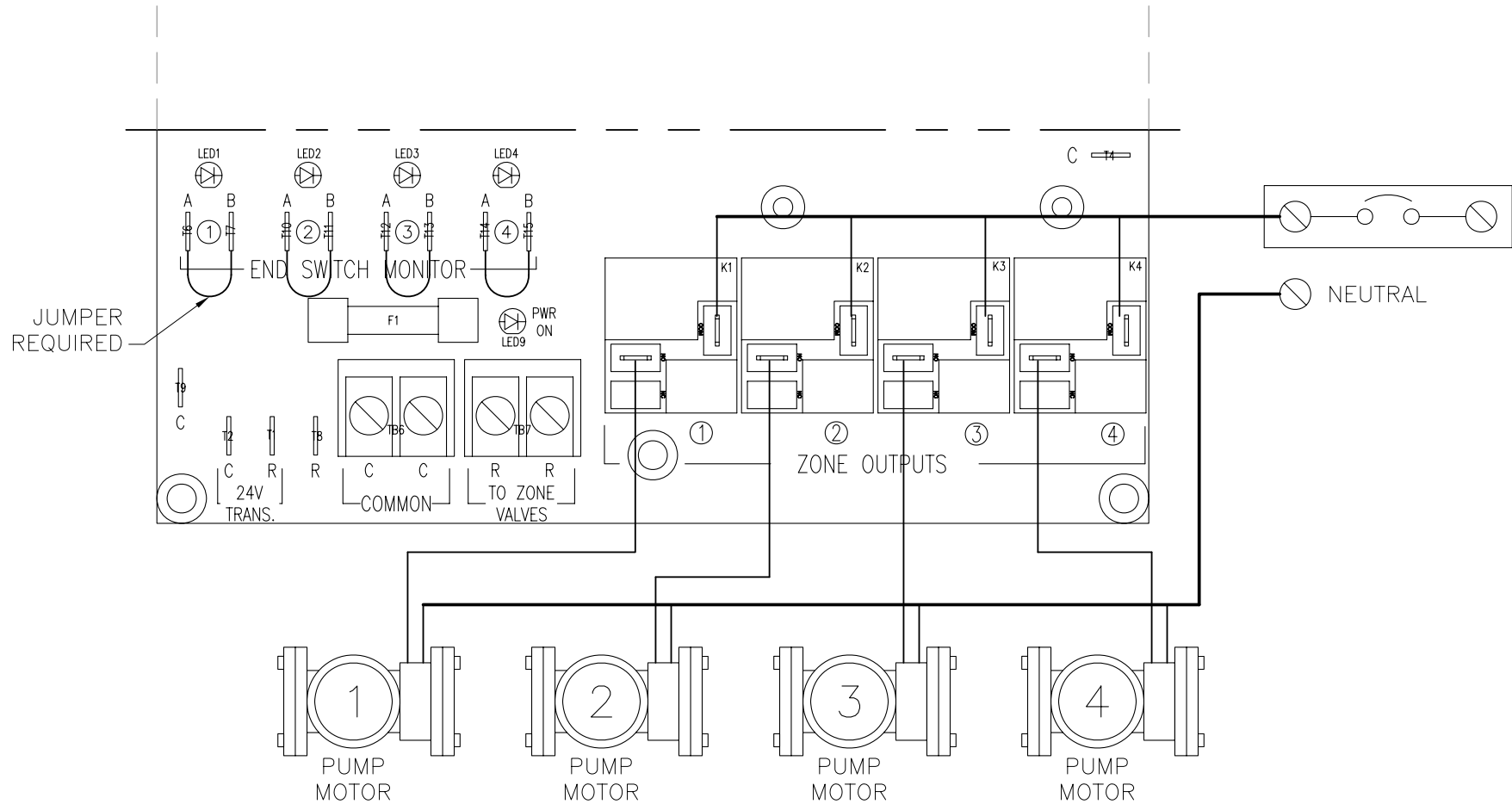

NOTES:

1. ADDITIONAL FOUR CAN BE CONTROLLED AND CONNECTED WITH EB-ZEA-2 SLAVE CONTROLLER.

EB-ZTA-1 / EB-ZEA-1

2 - 4 TACO SELF-CONTAINED (003Z - 0014Z)
 NO PUMP CONNECTION AT BOILER PUMP TB

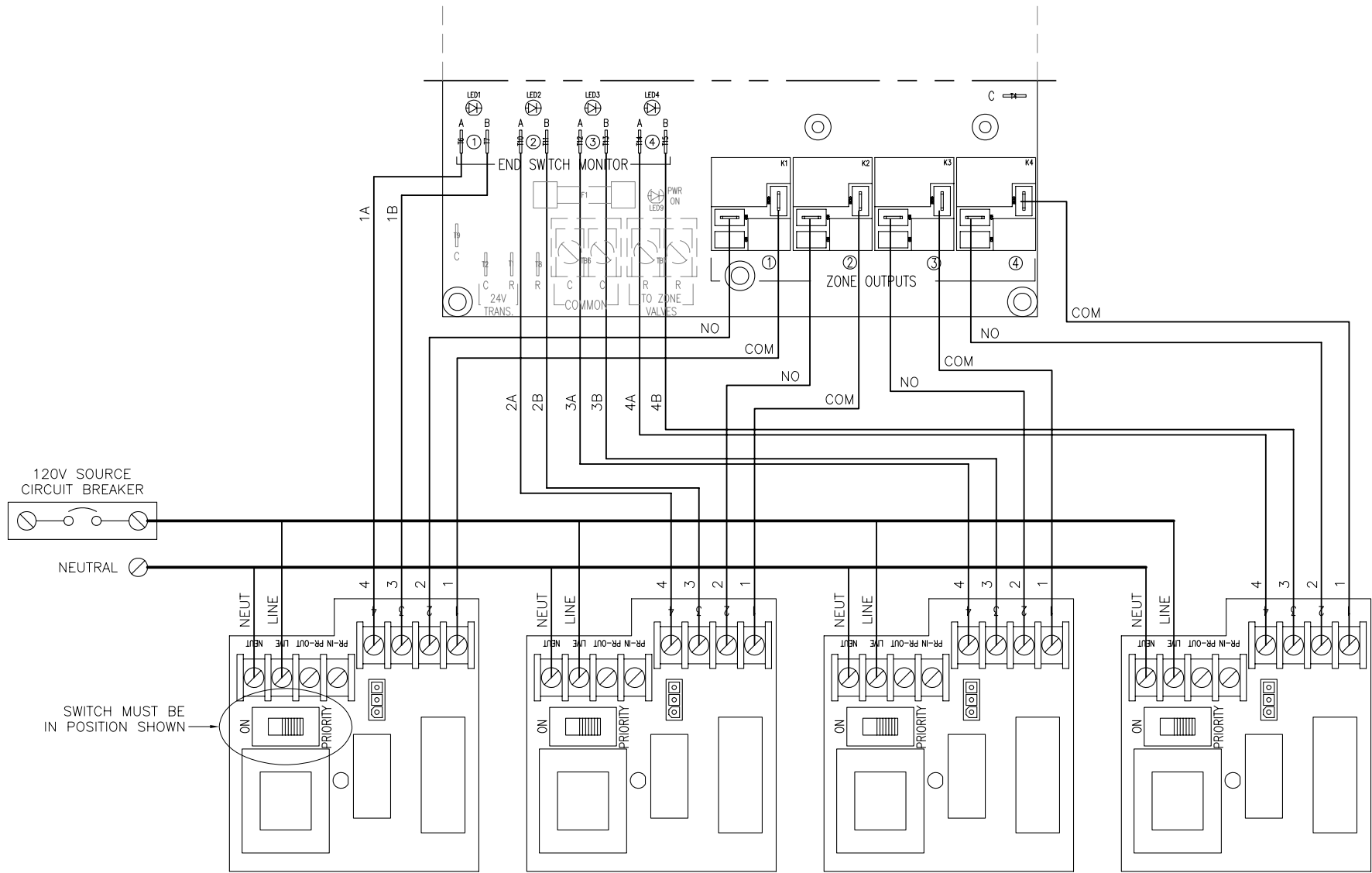

NOTES:

- 1. ADDITIONAL FOUR CAN BE CONTROLLED AND CONNECTED WITH EB-ZEA-2 SLAVE CONTROLLER.

EB-ZTA-1 / EB-ZEA-1

ZONE ACTUATORS OR 2-WIRE ZONE VALVES



ASSUME SINGLE PRIMARY PUMP (CONNECT TO BOILER TB CONTACT)

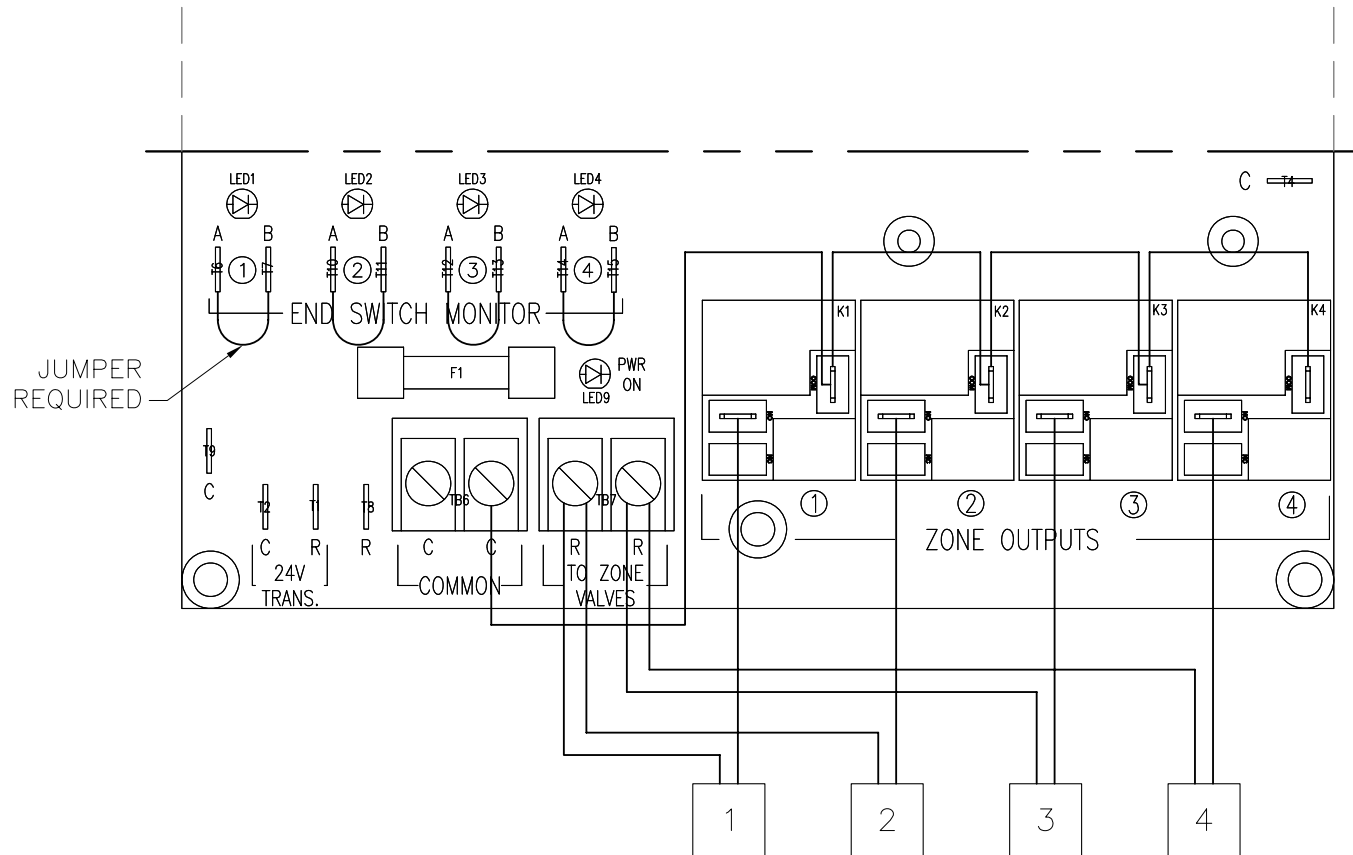

NOTES:

1. ADDITIONAL FOUR CAN BE CONTROLLED AND CONNECTED WITH EB-ZEA-2 SLAVE CONTROLLER.

EB-ZTA-1 / EB-ZEA-1 4-WIRE ZONE VALVES



ASSUME SINGLE PRIMARY PUMP (CONNECT TO BOILER TB CONTACT)

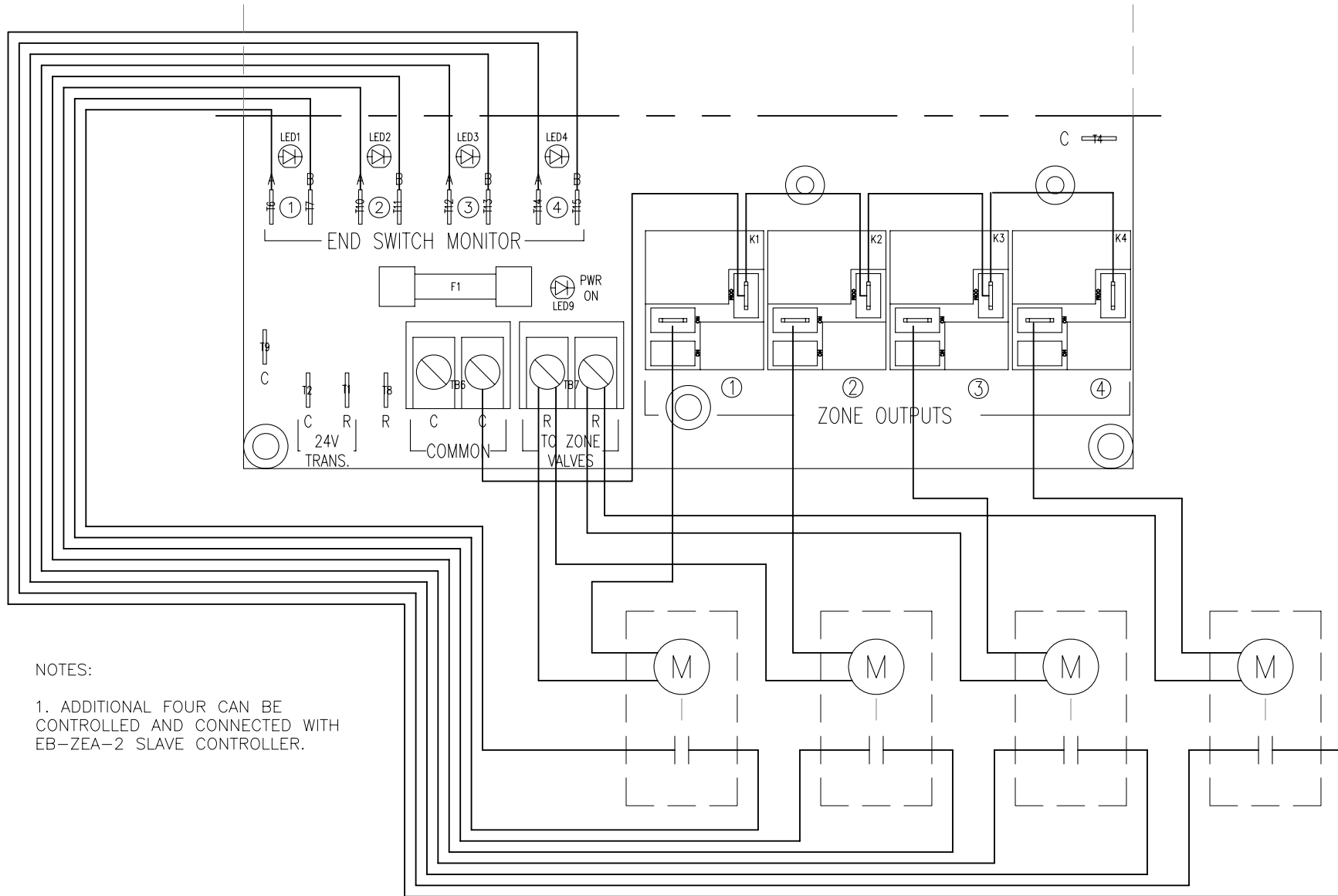

NOTES:

1. ADDITIONAL FOUR CAN BE CONTROLLED AND CONNECTED WITH EB-ZEA-2 SLAVE CONTROLLER.

EB-ZTA-1 / EB-ZEA-1 3-WIRE ZONE VALVES



ASSUME SINGLE PRIMARY PUMP (CONNECT TO BOILER TB CONTACT)

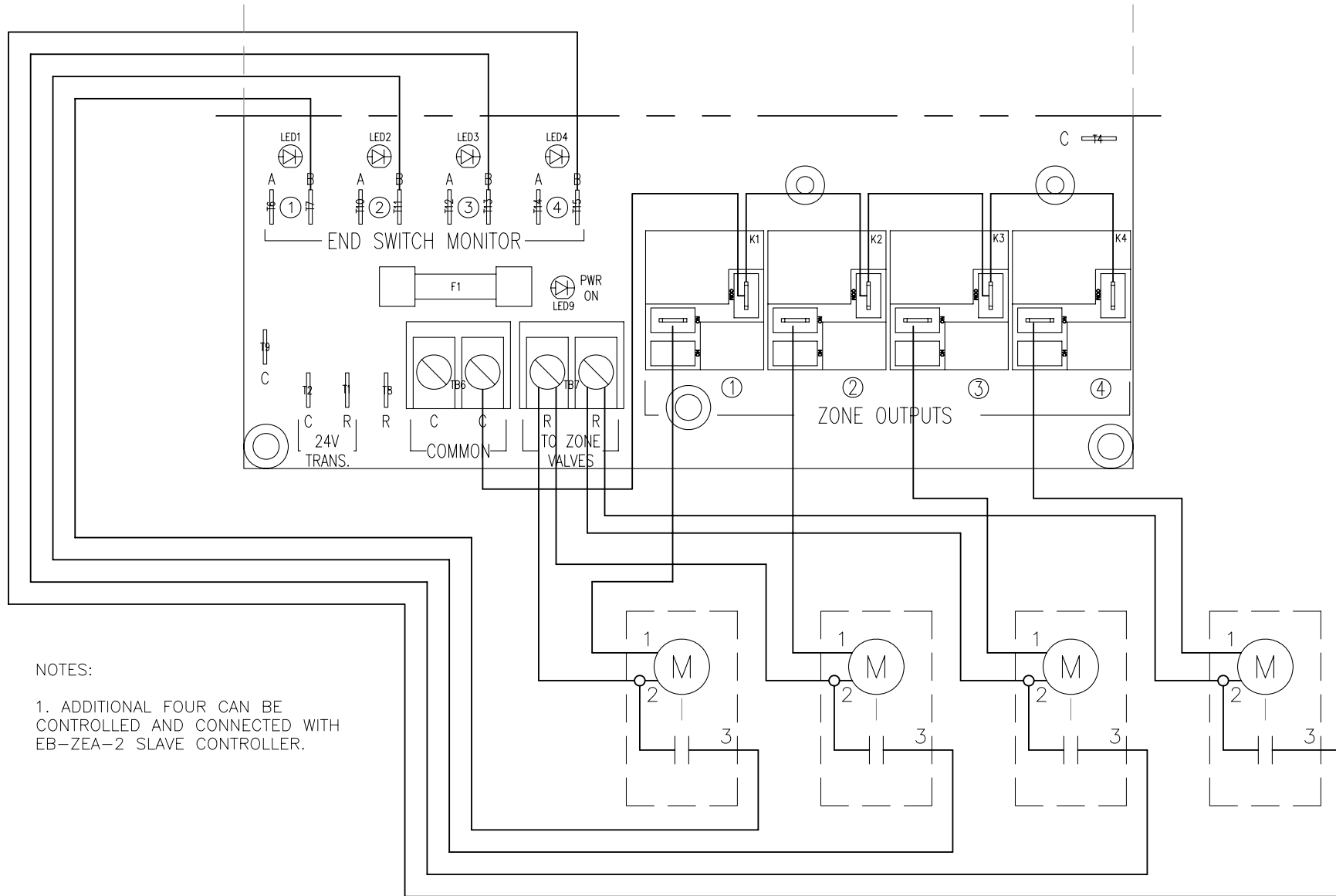

NOTES:

1. ADDITIONAL FOUR CAN BE CONTROLLED AND CONNECTED WITH EB-ZEA-2 SLAVE CONTROLLER.

EB-ZTA-1 CONTROLLER AND BOILER BOARD HOOKUP

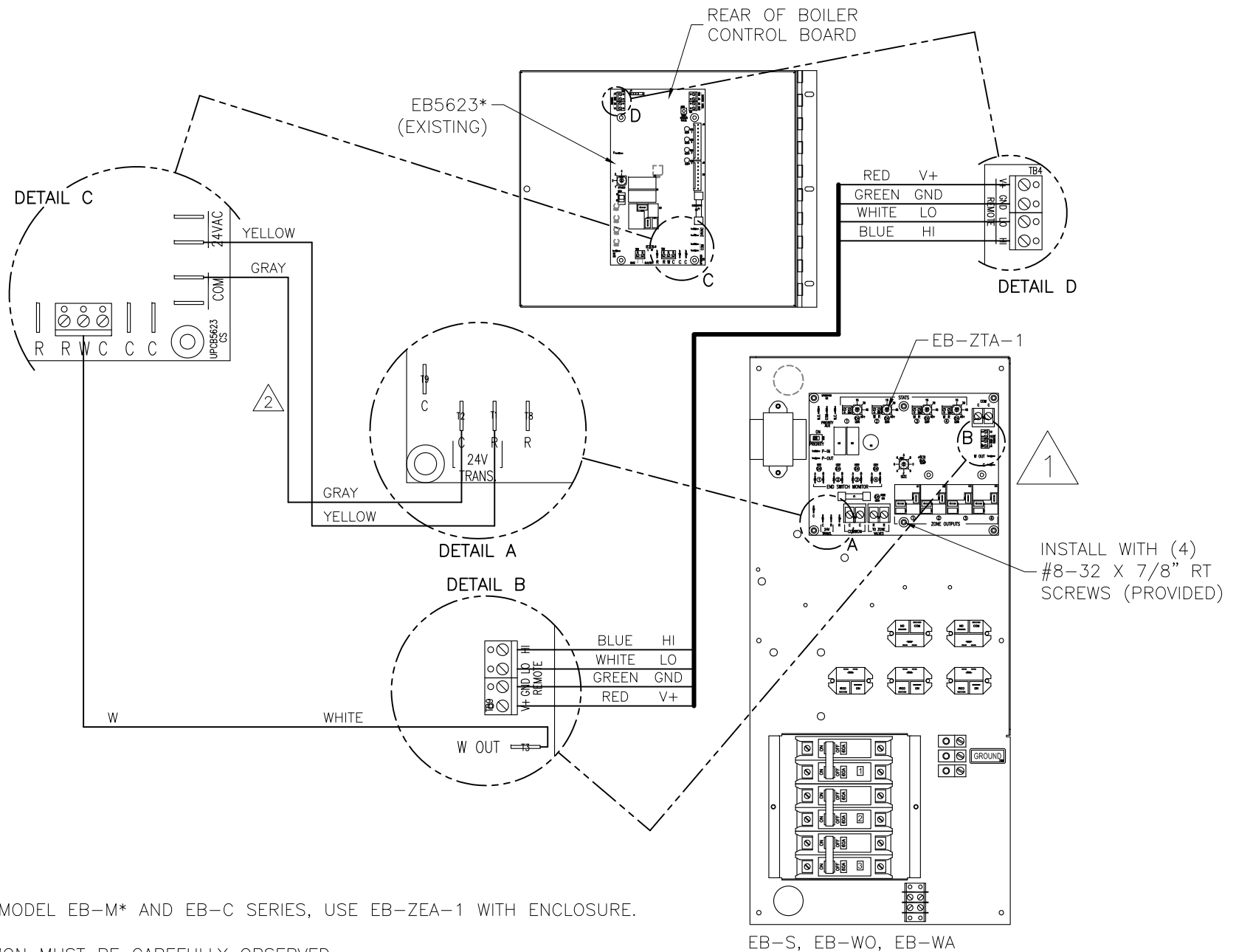

NOTES:

1. FOR MODEL EB-M* AND EB-C SERIES, USE EB-ZEA-1 WITH ENCLOSURE.

△ COMMON MUST BE CAREFULLY OBSERVED.

EB-ZEA-1 SAME EXCEPT ENCLOSURE AND TRANSFORMER

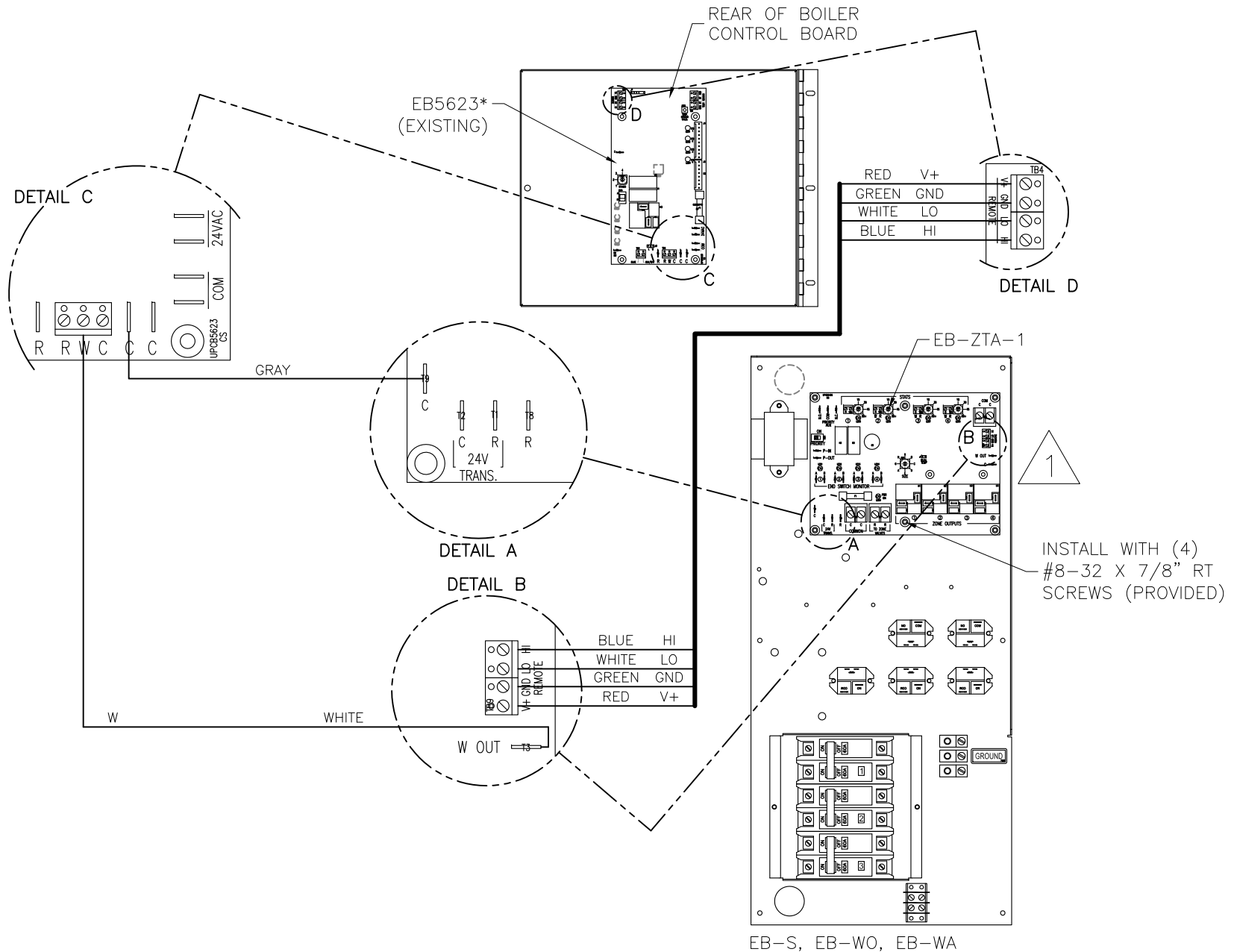

ELECTRO-STAT - ES-24-C-RS

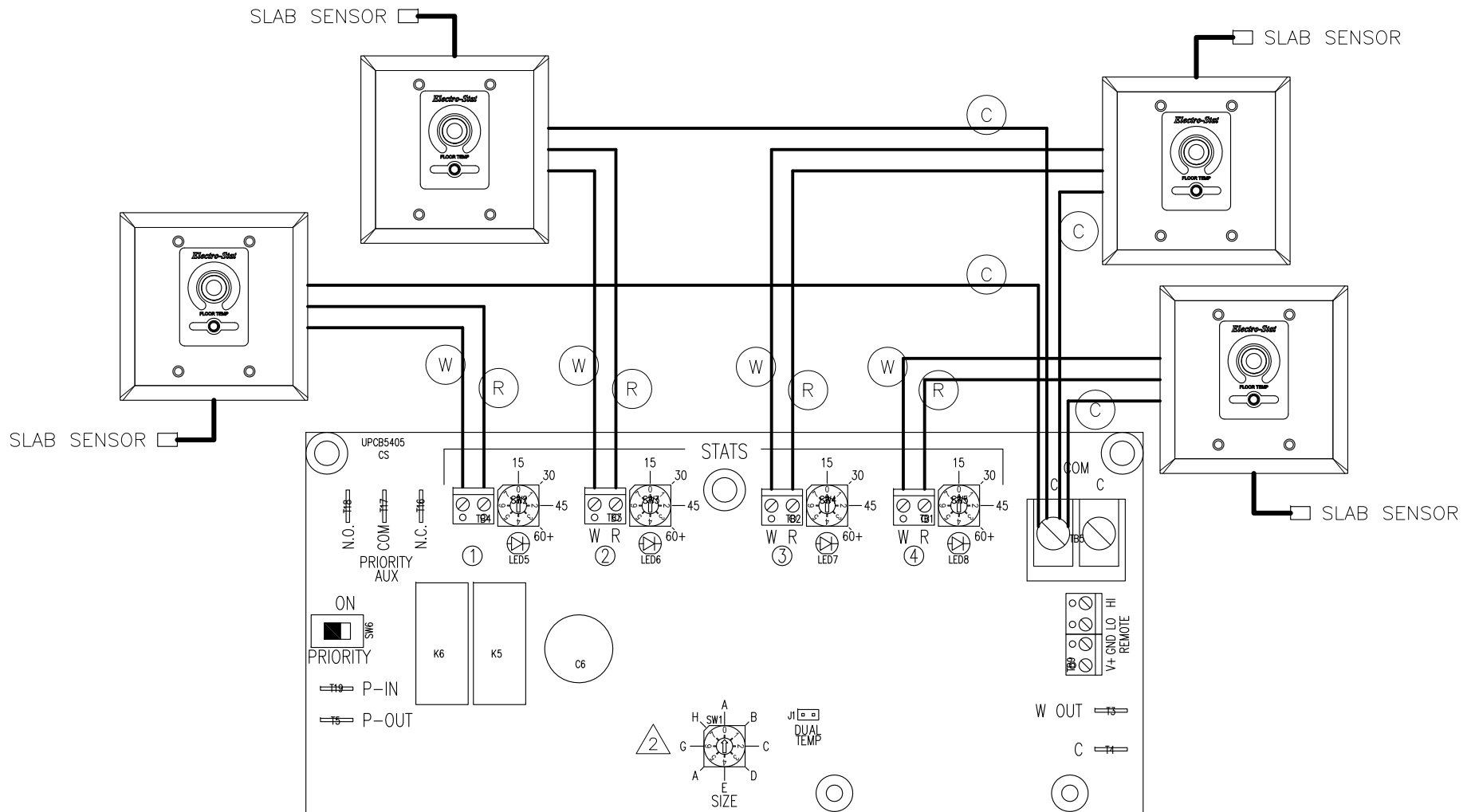

NOTES:

1. ZONE DIAL SWITCHES MUST BE SET FOR EACH ZONE BTUH LOAD CAPACITY.

2. SIZE OF DIAL SWITCH MUST MATCH BOILER MODEL AND KW. SEE MANUAL P.4.

AIR STAT OR CAPILLARY

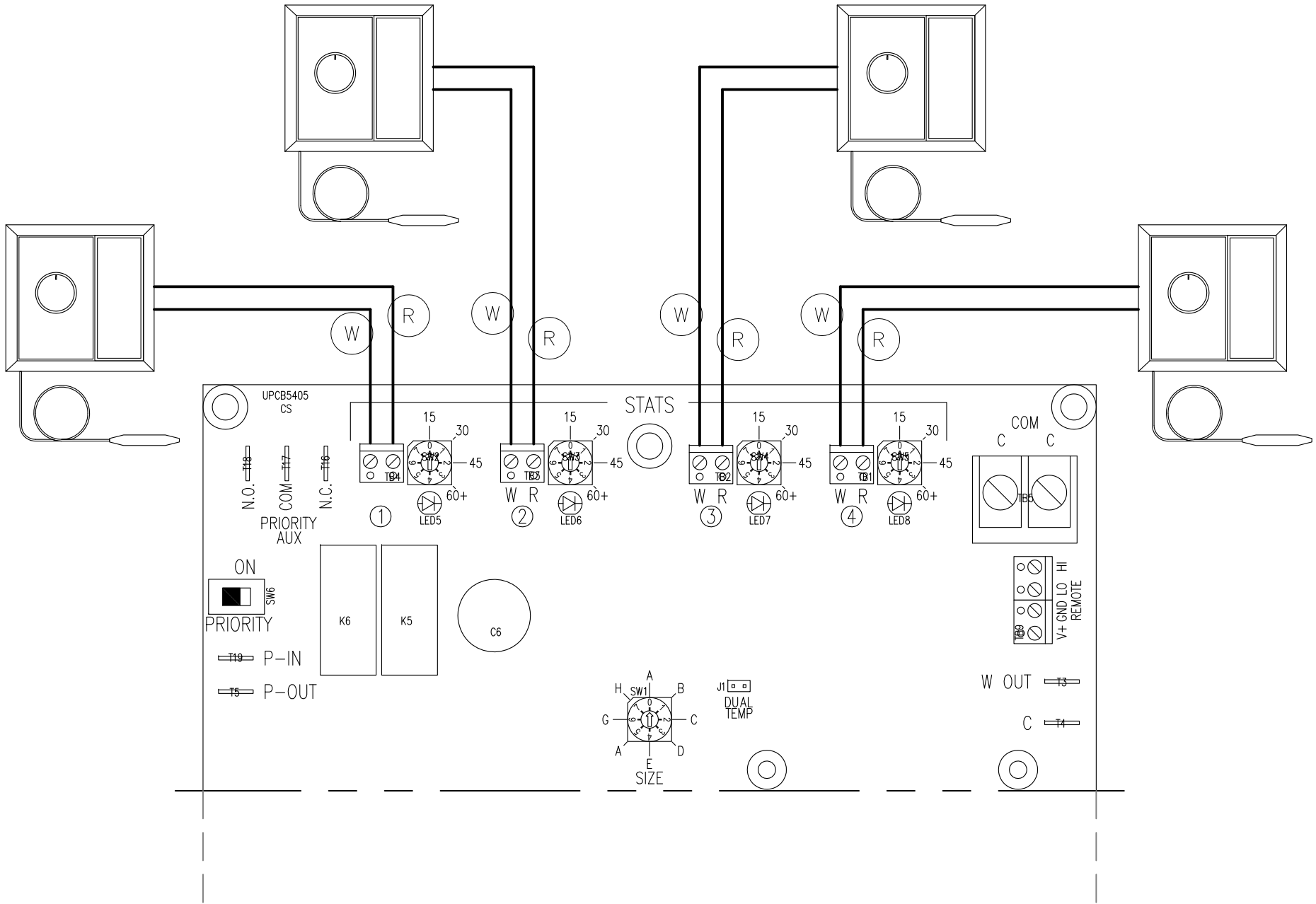

Electro Industries, Inc. Limited Product Warranty

Effective October 1, 2007

Electro Industries, Inc. warrants to the original owner, at the original installation site, for a period of two (2) years from date of installation, that the product and product parts manufactured by Electro Industries are free from manufacturing defects in materials and workmanship, when used under normal conditions and when such product has not been modified or changed in any manner after leaving the plant of Electro Industries. If any product or product parts manufactured by Electro Industries are found to have manufacturing defects in materials or workmanship, such will be repaired or replaced by Electro Industries. Electro Industries shall have the opportunity to directly, or through its authorized representative, examine and inspect the alleged defective product or product parts. Electro Industries may request that the materials be returned to Electro Industries at the owner's expense for factory inspection. The determination as to whether product or product parts shall be repaired, or in the alternative replaced, shall be made by Electro Industries or its authorized representative. Electro Industries will cover reasonable labor costs to repair defective product or product parts for ninety (90) days after installation.

TWENTY YEAR (20) LIMITED WARRANTY ON BOILER ELEMENTS AND VESSELS

Electro Industries, Inc. warrants that the boiler elements and vessels of its products are free from defects in materials and workmanship through the twentieth year following date of installation. If any boiler elements or vessels are found to have a manufacturing defect in materials or workmanship, Electro Industries will replace them.

TWENTY YEAR (20) LIMITED WARRANTY ON SPIN FIN ELEMENTS

Electro Industries, Inc. warrants that the spin fin elements of its products are free from defects in materials and workmanship through the twentieth year following date of installation. If any spin fin elements are found to have a manufacturing defect in materials or workmanship, Electro Industries will replace them.

FIVE YEAR (5) LIMITED WARRANTY ON OPEN WIRE ELEMENTS

Electro Industries, Inc. warrants that the open wire elements of its products are free from defects in materials and workmanship through the fifth year following date of installation. If any open wire elements are found to have a manufacturing defect in materials or workmanship, Electro Industries will replace them.



ELECTRO INDUSTRIES, INC.

2150 West River Street, PO Box 538, Monticello, MN 55362

763.295.4138 • 800.922.4138 • fax 763.295.4434

sales@electromn.com • www.electromn.com

THESE WARRANTIES DO NOT COVER:

1. Costs for labor for removal and reinstallation of an alleged defective product or product parts, transportation to Electro Industries, and any other materials necessary to perform the exchange, except as stated in this warranty. Replacement material will be invoiced to the distributor in the usual manner and will be subject to adjustment upon verification of defect.
2. Any product that has been damaged as a result of being improperly serviced or operated, including, but not limited to, the following: operated with insufficient water or airflow, allowed to freeze, subjected to flood conditions, subjected to improper voltages or power supplies, operated with airflow or water conditions and/or fuels or additives which cause unusual deposits or corrosion in or on the product, chemical or galvanic erosion, improper maintenance or subject to any other abuse or negligence.
3. Any product that has been damaged as a result of natural disasters, including, but not limited to, the following: lightning, fire, earthquake, hurricanes, tornadoes or floods.
4. Any product that has been damaged as a result of shipment or handling by the freight carrier. It is the receiver's responsibility to claim and process freight damage with the carrier.
5. Any product that has been defaced, abused, or suffered unusual wear and tear as determined by Electro Industries or its authorized representative.
6. Workmanship of any installer of the product. This warranty does not assume any liability of any nature for unsatisfactory performance caused by improper installation.
7. Transportation charges for any replacement part or component, service calls, normal maintenance; replacement of fuses, filters, refrigerant, etc.

CONDITIONS AND LIMITATIONS:

1. If at the time of a request for service the original owner cannot provide an original sales receipt or a warranty card registration then the warranty period for the product will have deemed to begin thirty (30) days after the date of manufacture and **NOT** the date of installation.
2. The product must have been sold and installed by a licensed electrical contractor, a licensed plumbing contractor, or a licensed heating contractor.
3. The application and installation of the product must be in compliance with Electro Industries' specifications as stated in the installation and instruction manual, and all state and federal codes and statutes. If not, the warranty will be null and void.
4. The purchaser shall have maintained the product in accordance with the manual that accompanies the unit. Annually, a qualified and licensed contractor must inspect the product to assure it is in proper working condition.
5. All related heating components must be maintained in good operating condition.
6. All lines must be checked to confirm that all condensation drains properly from the unit.
7. Replacement of a product or product part under this limited warranty does not extend the warranty term or period.
8. Before warranty claims will be honored, Electro Industries shall have the opportunity to directly, or through its authorized representative, examine and inspect the alleged defective product or product parts. Remedies under this warranty are limited to repairing or replacing alleged defective product or product parts. The decision whether to repair or, in the alternative replace, products or product parts shall be made by Electro Industries or its authorized representative.

THESE WARRANTIES DO NOT EXTEND TO ANYONE EXCEPT THE ORIGINAL PURCHASER AT RETAIL AND ONLY WHEN THE PRODUCT IS IN THE ORIGINAL INSTALLATION SITE. THE REMEDIES SET FORTH HEREIN ARE EXCLUSIVE.

ALL IMPLIED WARRANTIES, INCLUDING WARRANTIES OF MERCHANTABILITY AND FITNESS FOR A PARTICULAR PURPOSE, ARE HEREBY DISCLAIMED WITH RESPECT TO ALL PURCHASERS OR OWNERS. ELECTRO INDUSTRIES, INC. IS NOT BOUND BY PROMISES MADE BY OTHERS BEYOND THE TERMS OF THESE WARRANTIES. FAILURE TO RETURN THE WARRANTY CARD SHALL HAVE NO EFFECT ON THE DISCLAIMER OF THESE IMPLIED WARRANTIES.

ALL EXPRESS WARRANTIES SHALL BE LIMITED TO THE DURATION OF THIS EXPRESS LIMITED WARRANTIES SET FORTH HEREIN AND EXCLUDE ANY LIABILITY FOR CONSEQUENTIAL OR INCIDENTAL DAMAGES RESULTING FROM THE BREACH THEREOF. SOME STATES DO NOT ALLOW THE EXCLUSION OR LIMITATION OF INCIDENTAL OR CONSEQUENTIAL DAMAGES, SO THE ABOVE LIMITATIONS OR EXCLUSIONS MAY NOT APPLY. PRODUCTS OR PARTS OF OTHER MANUFACTURERS ATTACHED ARE SPECIFICALLY EXCLUDED FROM THE WARRANTY.

THIS WARRANTY GIVES YOU SPECIFIC LEGAL RIGHTS, AND YOU MAY HAVE OTHER RIGHTS WHICH VARY UNDER THE LAWS OF EACH STATE. IF ANY PROVISION OF THIS WARRANTY IS PROHIBITED OR INVALID UNDER APPLICABLE STATE LAW, THAT PROVISION SHALL BE INEFFECTIVE TO THE EXTENT OF THE PROHIBITION OR INVALIDITY WITHOUT INVALIDATING THE REMAINDER OF THE AFFECTED PROVISION OR THE OTHER PROVISIONS OF THIS WARRANTY.