

Pump Zone Controller Add-On TS Series Boiler

EB-Z2P

Application

Special automatic or built-in **shift** to higher water temperature for **priority** zone 1. In many combination temperature installations this feature eliminates mixing valve or injection pump temperature control.

Built-in automatic stage shedding based upon the capacity of each active zone. This compensates for any mixture of large and small zones.

This controller is setup for two zone pumps. If one of the zone pumps also has zone valves, model EB-ZTS-2 externally mounted zone valve controller can be added.

The typical configuration is a high temperature zone (pump) and a low temperature zone (pump). When adding the EB-ZTS-2 zone valve controller, either or both of these pump zones can have an additional four zone valves and zone thermostats. Enclosed hookup drawing page 1 shows the configuration with the added 4-zone controller.

Features

- Dual Control Temperature, Priority Zone*
- Digital or Standard Thermostat Compatible*
- Three LED Onboard Lights, each Stat and basic power*
- Control Board only, installed within TS Boiler*
- Remote Data Communication to Boiler Control Board*
- Extra Priority Relay Contact*

Configuration

Electro Industries EB-S, EB-WO, or EB-WA model series boilers.

- This is a control board only, mounts within the boiler cabinet
- If model EB-S-**, unit must be manufactured after approximately January 10, 2004 with REMOTE TERMINAL BLOCK arrangement. If an older unit and the upper left control board corner (door open) does not have a remote terminal block, request upgrade EBSTU5623 main boiler control board (exchange may be possible)

Also all software program chips must be version 5.20, 6.20, and 3.20 or higher.

Drawings: **BH017**



ELECTRO INDUSTRIES, INC.

2150 West River Street, PO Box 538, Monticello, MN 55362
763.295.4138 • 800.922.4138 • fax 763.295.4434
sales@electromn.com • www.electromn.com

Unique Zone Controller Dual Temp. Feature

The switch-able priority has the normal function of allowing zone 1 to override or hold off all other zones so that the boiler can produce full capacity energy for zone 1 capacity requirement. **In addition**, this zone controller with the TS boiler also automatically raises the outlet temperature for low mass, high supply temperature zone.

- Example – zone #1-baseboard fin tube, air handler coil, staple-up, etc.

With this feature zone 1 is always the high temperature requirement, the priority switch must be on, and all remaining zones are connected to under floor radiant tubing with the outlet temperature for the radiant zones controlled at the front panel red knob set point.

Model EB-S-** Comment

1. This zone controller board requires a main boiler control board with remote communication capability. Units factory manufactured after approximately January 10, 2004 have the updated control board with REMOTE. Also must be program chip version 5.20 and above. For older unit updates call factory, also see cover page.

Installation/Hookup - Controller

Reference: Drawing BH017 page 2

1. Since this zone controller board is installed within the Electro-Boiler TS Series cabinet, it is assumed you have one of the models listed in the Configuration section.
2. Depending upon the factory order, this control board may have been installed prior to shipment.
3. This control board mounts on the inside chassis, above the element power relays.
4. Connect a 4-wire thermostat cable between the terminal block marked REMOTE and the same terminal block on the boiler control board. This must be point to point, V+ to V+, etc.
5. This zone controller board 24V source is tapped from Electro-Boiler transformer. Parallel wire 24VAC tab and COM tab.
6. The “operate” signal for the boiler is taken care of by adding a wire between W OUT and boiler main board W.

Installation/Hookup – Two Pumps and Two Thermostats (Basic)

Reference: Drawing BH017 pages 2 and 3

1. Connect slab stat or temperature sensing **thermostat** to the bottom terminal block “R and W”. If using Electro-Stat, a common is required at each Electro-Stat. Common is available at the lower right terminal block. Drawing shows typical hookups for various thermostats. Connect per your selected thermostat, typically will be one type, not both.
2. The right side two relays represent a contact closure for the pump motor. The pump 120-volt source is connected to each COM terminal of each relay and the NO tab of each relay goes to each pump.
3. If using priority high temperature/low mass feature, zone 1 and connected stat 1 must be the high temperature zone.

Installation/Hookup – Added Zone Controllers

Depending upon whether the zones are connected to the high temperature pump or the low temperature pump or both, there is a different arrangement for adding zone controllers.

In the following zone controller arrangements, the basic hookup detailed above applies (pages 2 and 3). The zone controller simply connects to or replaces the slab stats (thermostat) stated above. In other words, the external zone controller provides the R and W for the EB-Z2P board.

- A. High Temp Pump, One Stat/Low Temp Pump, Zone Controller** – add EB-ZTS-2 for the low temp zones, 4 maximum.

Reference: Drawing BH017, page 4 – zone thermostats, zone valves, setup capacity dial switches, etc. are wired as stated within the EB-ZTS-2 installation manual. The remote bus and “W-OUT” are shown on BH017, page 4. The EB-Z2P pump 2 turn-on or input comes from the large relay contact closure in the EB-ZTS-2 zone board.

- B. High Temp Pump, Zone Controller/Low Temp Pump, One Stat** – add EB-ZTS-2 zone controller.

Reference: Drawing BH017, page 5 – zone thermostats, zone valves, setup capacity dial switches, etc. are wired as stated within the EB-ZTS-2 installation manual. This is simply a reverse from A above. The remote bus cable and “W-OUT” wire are connected per page 6. The EB-Z2P pump 2 turn-on or input comes from the large relay contact closure in the EB-ZTS-2 zone board.

- C. High Temp Pump, Zone Controller/Low Temp Pump, Zone Controller** – add EB-ZTS-2 for the high temp and EB-ZC-4 for the low temp.

Reference: Drawing BH017, page 6 - zone thermostats, zone valves, setup capacity dial switches, etc. are wired as stated within the EB-ZTS-2 installation manual. This provides the capability for four zones (zone valves) in the high temperature pump loop and four zone valves in the low temperature pump loop. The remote bus and “W-OUT” are shown on BH017, page 7. The EB-Z2P pump 2 turn-on or input comes from the large relay contact closure in the EB-ZTS-2 zone board.

The EB-ZC-4 for the low temp zones does not have capacity switches, connect end switch contact as shown on page 7. The EB-ZTS-2, with capacity dial switches and remote bus, is used for the high temp zones and also shown on page 7.

Comment/Warning: Options B or C above may seem like a good idea, but carefully consider the meaning of “priority” before electing to use B or C in your system. In order to activate the high temperature, priority switch must be on. By hardware definition within the EB-Z2P, the priority switch means that stat 1 input deactivates or disables the input for stat 2 or its associated zone controller in the C option. You need to carefully evaluate the size of the zones on the high temperature zone controller and how often or for what predictable duration will they be on. Do not use this scheme if there is a possibility of the high temperature zones going in and out throughout the normal heating day and thus keeping off the low temperature floor heating zones to the point where the floor never gets “charged”. Another possibility for using B or C would be a timer on the WF-Z2P stat 1 input such that stat 1 or priority can only be on for X number of hours until all of stat 2 zones are satisfied. This type of arrangement could also include a time clock where stat 1 inputs are off during the nighttime and stat 2 inputs are used to “recharge” the floor.

Thermostat Heat Anticipator Setting

Set at approximately 0.25.

Setup – Zone Sizes and Boiler Sizes

On the zone valve controller board there are three dial switches. Two relate to each zone and SIZE relates to boiler information.

Zone capacity size setting – from building design information and/or zone capacity calculations, installer must know the approximate BTUH capacity of each zone. The last page “Staging” section describes this calculation process. Dial in this capacity for each zone:

- 0 = 15,000 BTUH
- 1 = 30,000 BTUH
- 2 = 45,000 BTUH
- 3 = 60,000 BTUH

The 5th dial switch must be set to the boiler **size**.

Model	Boiler Size	Size Dial Switch Position	Zone Dial Switch Multiplier ²
EB-*-10	10 kW	A	1
EB-*-13	13 kW	A	1
EB-*-15	15 kW	B	1
EB-*-18	18 kW	B	1
EB-*-20	20 kW	C	1
EB-*-23	22.5 kW	C	1
EB-*-27	27 kW	D	1
EB-C-27-*	27 kW	D	1
EB-C-40-*	40.5 kW	D	1
EB-C-31 & -36	31 or 36 kW	D	2
EB-C-18-48	18 kW	C	1.4
EB-C-36-48	36 kW	D	1.4
EB-C-54-48	54 kW	D	1.4

Notes

1. When in priority, all stages of the boiler come on and the above is bypassed.
2. When using this to switch the EB-C-*** boiler, the Btu settings next to the stat input dial switch may need to relate a different value. This column represents a multiplier times the dial switch setting Btu value. Example – for the 54 kW boiler the 0 position dial switch (15,000) now really represents $15,000 \times 1.4 = 21,000$.
3. Position E is not used. F, G, and H relate to multiple boilers.

Multiple Boilers, Using EB-C-STG5 Staging Relay

It is assumed the zoning arrangement has one or two small zones which can be handled by the first boiler and primarily large zones which will require stepping up to the next boilers. There are three boiler **size** settings and the first decision relates to proper zone connection and discerning the large zones wired into this zone controller. In this case the term “large zone” would mean the capacity of the complete boiler system (multi-boilers) is required to satisfy the capacity of “large” zone(s). Set the large zone dial switch to position 3, but in this position it is assumed more than the **master** boiler is required and all element stages will be activated, based upon boiler outlet temperature sensing. For zone 1 and including a slave zone controller (-2 model), the dial setting needs to be related to the zone Btu capacity which is communicated and related back to element stage zoning for the first or master boiler.

- “F” – one large zone which needs to be tied into #4. Zones 1, 2, and 3 require setting the dial switch representing the Btu’s for this zone and can be related to the Btu numbers in the above chart.
- “G” – two large zones which need to be tied into #3 and #4. Zones 1 and 2 require setting the dial switch representing the Btu’s for each zone and can be related to the Btu numbers in the above chart.
- “H” – three large zones which need to be tied into #2, #3, and #4. Zone 1 requires setting the dial switch representing the Btu’s for each zone and can be related to the Btu numbers in the above chart.

Priority High Temperature Zone Function

Application – one zone requires higher supply temperature (typically low mass) and the remaining zones require low temperature (typically high mass).

Note: When zone 1 is activated with the priority switch on, the zone size dial setting for zone 1 is bypassed. In this arrangement, the zone control board allows the master boiler to regulate the staging and temperature requirements needed for zone 1. In other words, it is possible that the full capacity of the boiler or boilers will be on during the priority call.

1. The stat relating to priority **must be stats 1, R and W**.
2. The zone valve or pump relating to priority must be zone 1.
3. Priority switch must be in “ON” position.
4. With priority on and stat 1 “W” terminal at 24 volts, pump relay 1 is closed and pump relay 2 is interrupted.
5. The LED associated with the stat inputs is active and shows the stat status. Pump relay 2 itself is interrupted under priority.
6. With stat 1 input and priority switch on, the boiler outlet temperature will regulate at one of two preset values: 150° F or 176° F. At the boiler main control board (hinged door) approximate center left side is a 2-pin jumper associated with the markings **J7**.
 - a. 150° F – as factory shipped, the 2-pin header is installed as a jumper.
 - b. 176° F – remove the 2-pin shorting block header.
7. “Priority AUX” is a dry contact terminal block, which is a direct function of zone 1 end switch terminal (3 to 4).
8. After a 60-minute timeout, zones 2, 3, and 4 are released to respond to stat inputs. Zone 1 could remain active, but any other zones that are calling will respond as if the system is not in priority. Zone 1 also returns to a normal stat input. The supply temperature drops to front panel setting. An interruption of zone 1 “W” terminal or turning priority switch off/on resets this 60-minute timer.

Note: All elements (stage LED’s) may be off until supply temperature drops to front panel red knob set point.

Monitor LED’s

- Power on – green LED represents good fuse and 24-volt transformer source.
- Slab stat or temperature sensing thermostat inputs – illuminates with voltage at “W”.

Staging

The actual boiler stages are controlled within the boiler main board from the information calculated within the zone controller board and communicated to the boiler main board. The sum of the various zone input dial switches determines which boiler stages are active. The zone dial switches calculation has priority over the temperature sensing. However, if the temperature sensing indicates the vessel is suddenly rising, it will override and turn off stages.

The number of stages will depend upon capacity calculations from the settings. The capacity dial switch position has an assigned value:

15,000 Btu/h = 1
30,000 Btu/h = 2
45,000 Btu/h = 3
60,000 Btu/h = 4

As the zone stats turn on and off these are added for a boiler staging sum. This sum value controls stage per:

1 = Stage 1
2 = Stage 2
3 = Stage 3
4 = Stage 4

There is an approximate 6 to 60-second delay between stage-up turn on and less than 4-second delay on stage-down.

EB-Z2P, TWO ZONE PUMP CONTROLLER HOOKUP 1

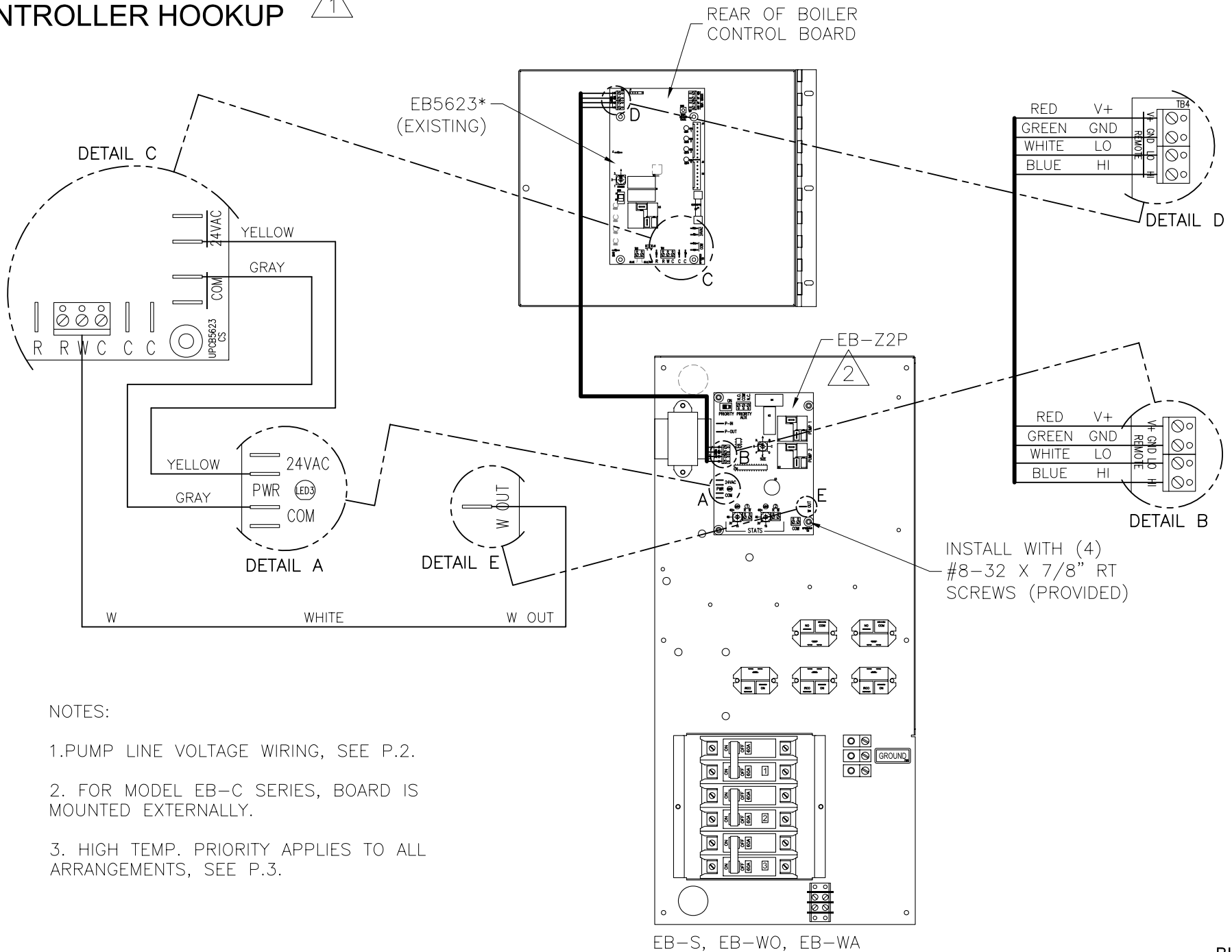

NOTES:

1. PUMP LINE VOLTAGE WIRING, SEE P.2.
2. FOR MODEL EB-C SERIES, BOARD IS MOUNTED EXTERNALLY.
3. HIGH TEMP. PRIORITY APPLIES TO ALL ARRANGEMENTS, SEE P.3.

EB-S, EB-WO, EB-WA

EB-Z2P, TWO ZONE PUMP PUMP & STAT WIRING

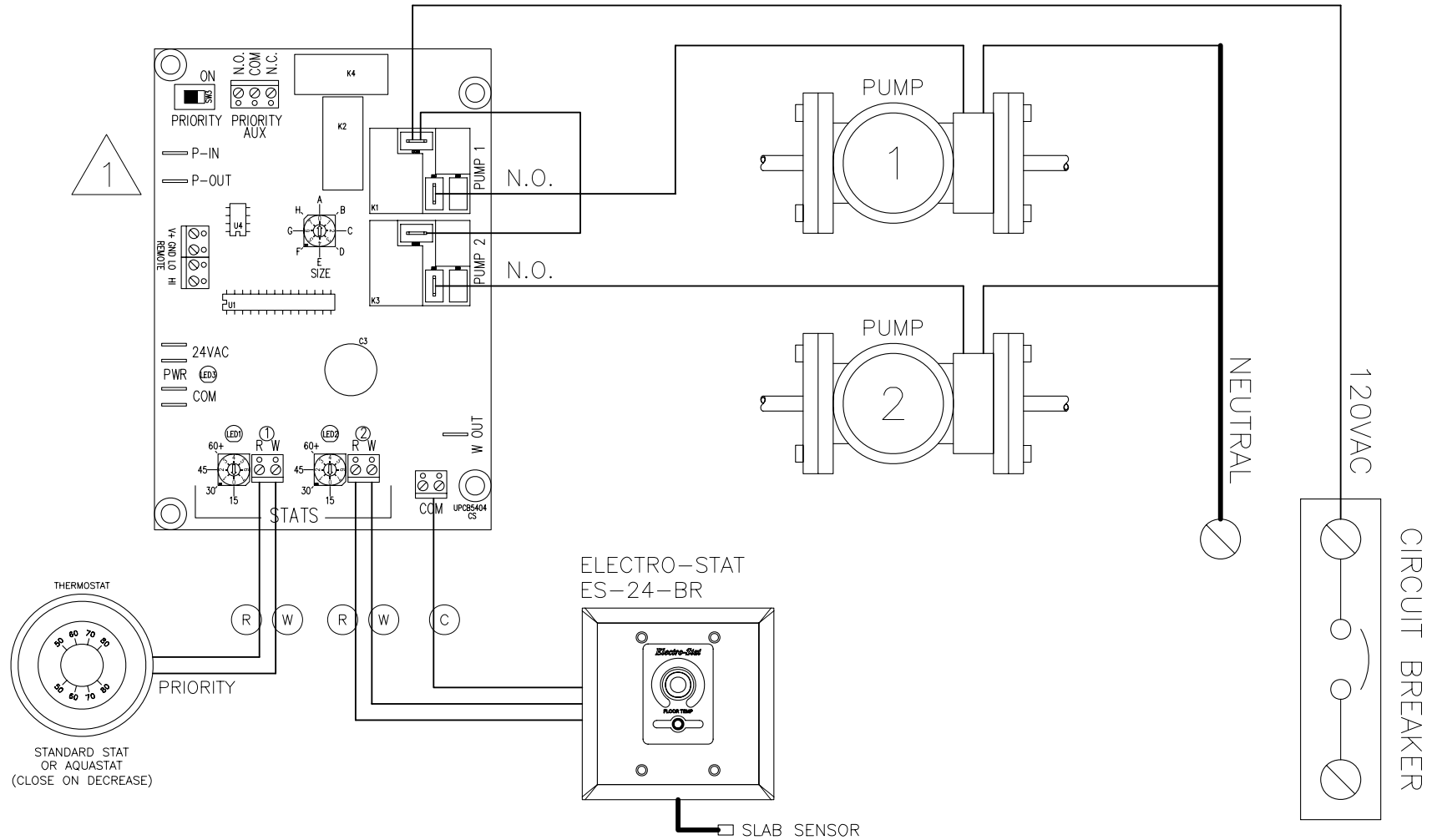

NOTES:

1. IF ADDING ZONE CONTROLLER AS SHOWN ON P.3, P-OUT WILL CONNECT TO EB-ZTS-2 AS SHOWN ON P.3.

Dual Temperature Boiler Application - Graphic Example

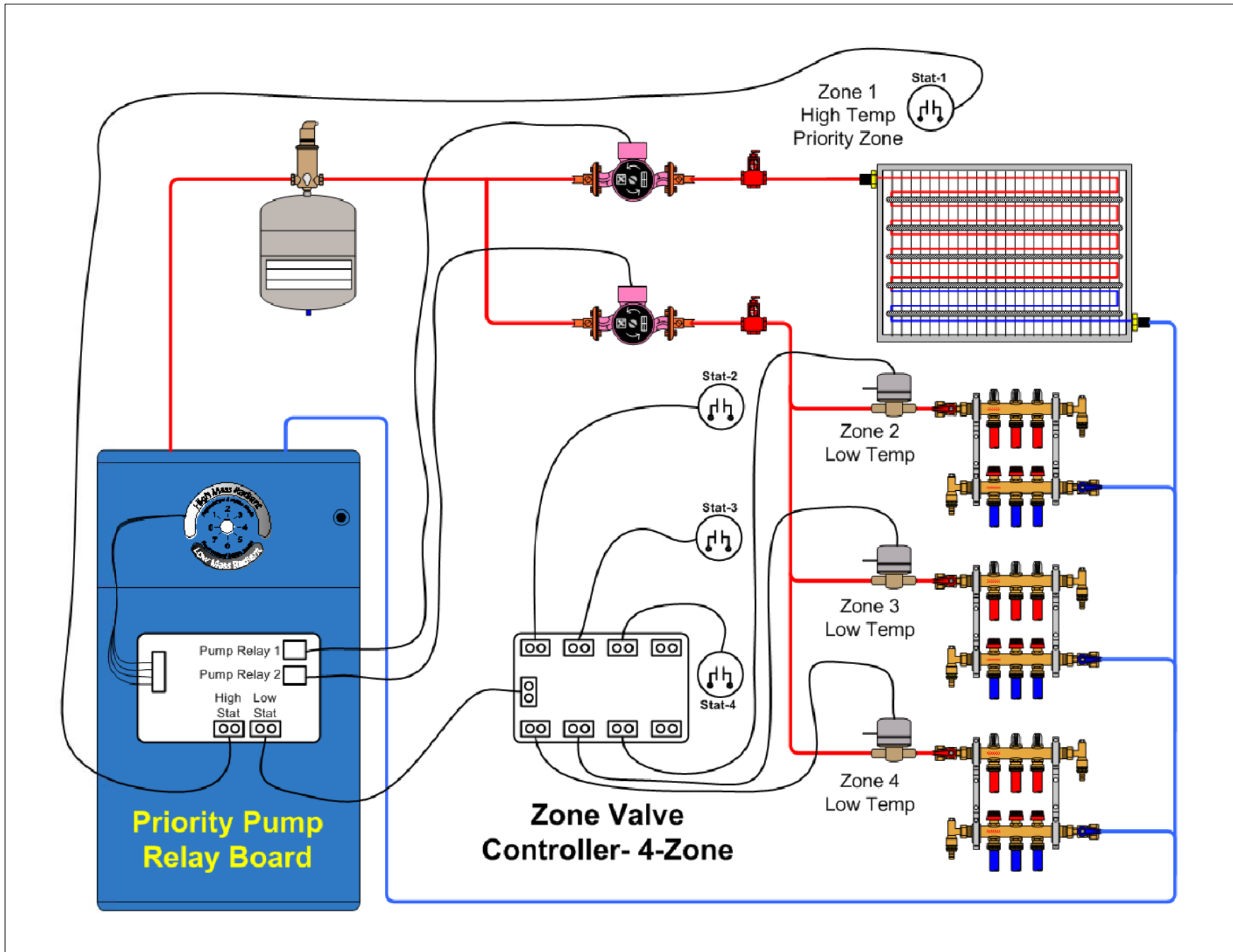

EB-Z2P & EB-ZEA-2

ONE HIGH TEMP. AND ZONE PUMPS, ADDED TO LOW TEMP LOOP

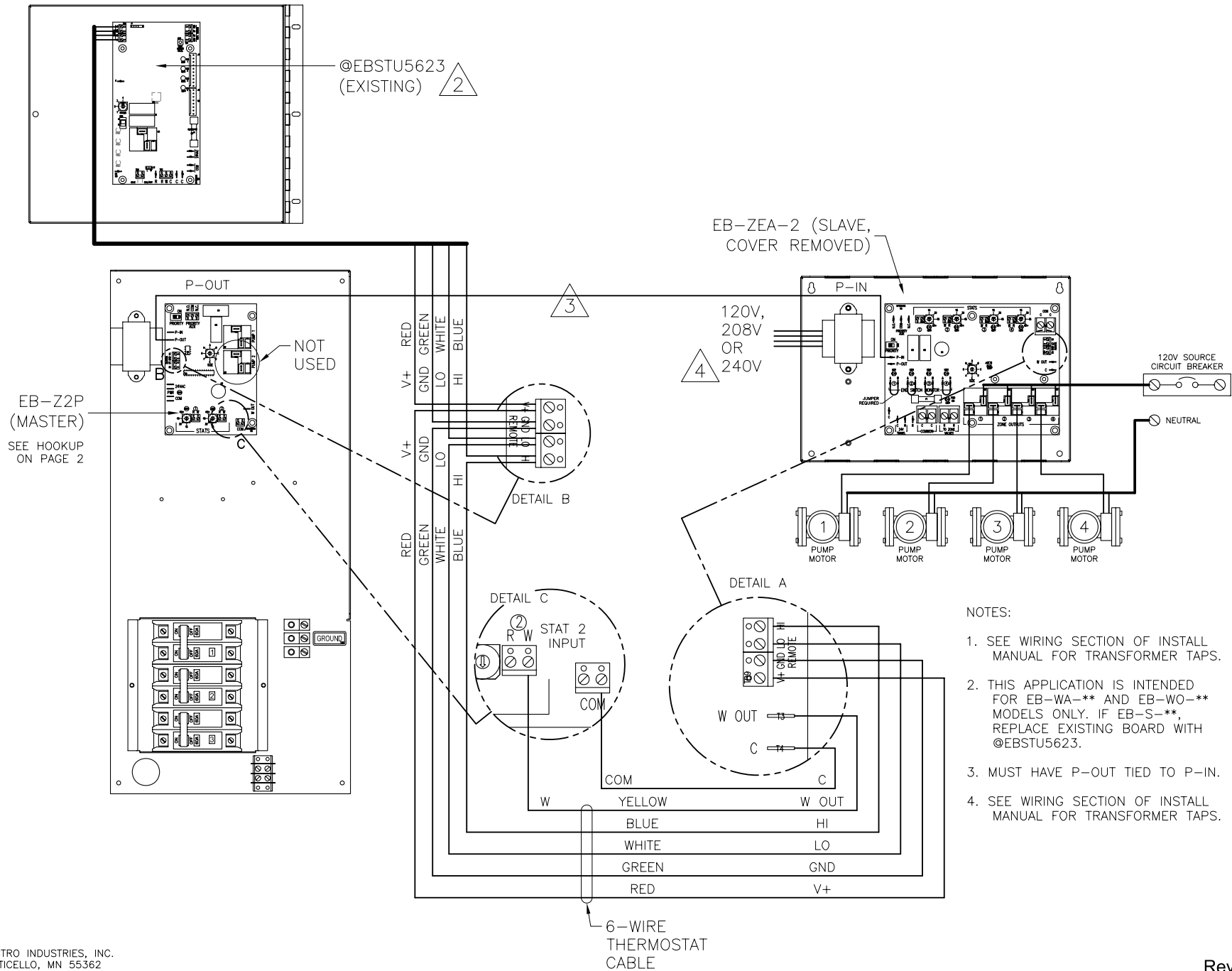

NOTES:

1. SEE WIRING SECTION OF INSTALL MANUAL FOR TRANSFORMER TAPS.
2. THIS APPLICATION IS INTENDED FOR EB-WA-*** AND EB-WO-*** MODELS ONLY. IF EB-S-***, REPLACE EXISTING BOARD WITH ①EBSTU5623.
3. MUST HAVE P-OUT TIED TO P-IN.
4. SEE WIRING SECTION OF INSTALL MANUAL FOR TRANSFORMER TAPS.

EB-Z2P & EB-ZTS-2 ZONE VALVES, ADDED TO LOW TEMP LOOP PUMP (OPTION A)

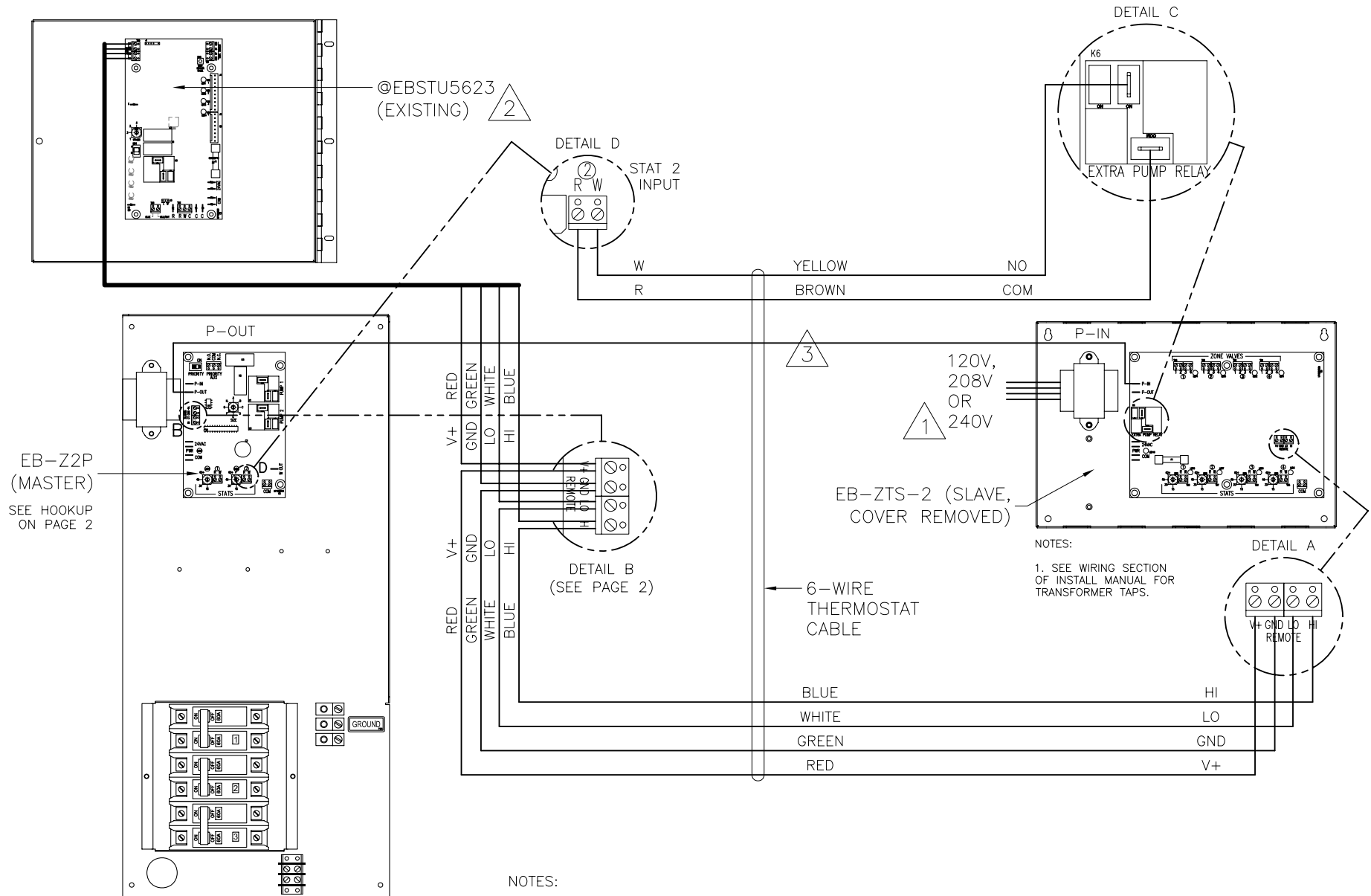

NOTES:

1. SEE WIRING SECTION OF INSTALL MANUAL FOR TRANSFORMER TAPS.
2. THIS APPLICATION IS INTENDED FOR EB-WA-** AND EB-WO-** MODELS ONLY. IF EB-S-**, REPLACE EXISTING BOARD WITH ©EBSTU5623.
3. MUST HAVE P-OUT TIED TO P-IN.

EB-Z2P & EB-ZTS-2 ZONE VALVES, ADDED TO HIGH TEMP LOOP PUMP (OPTION B)

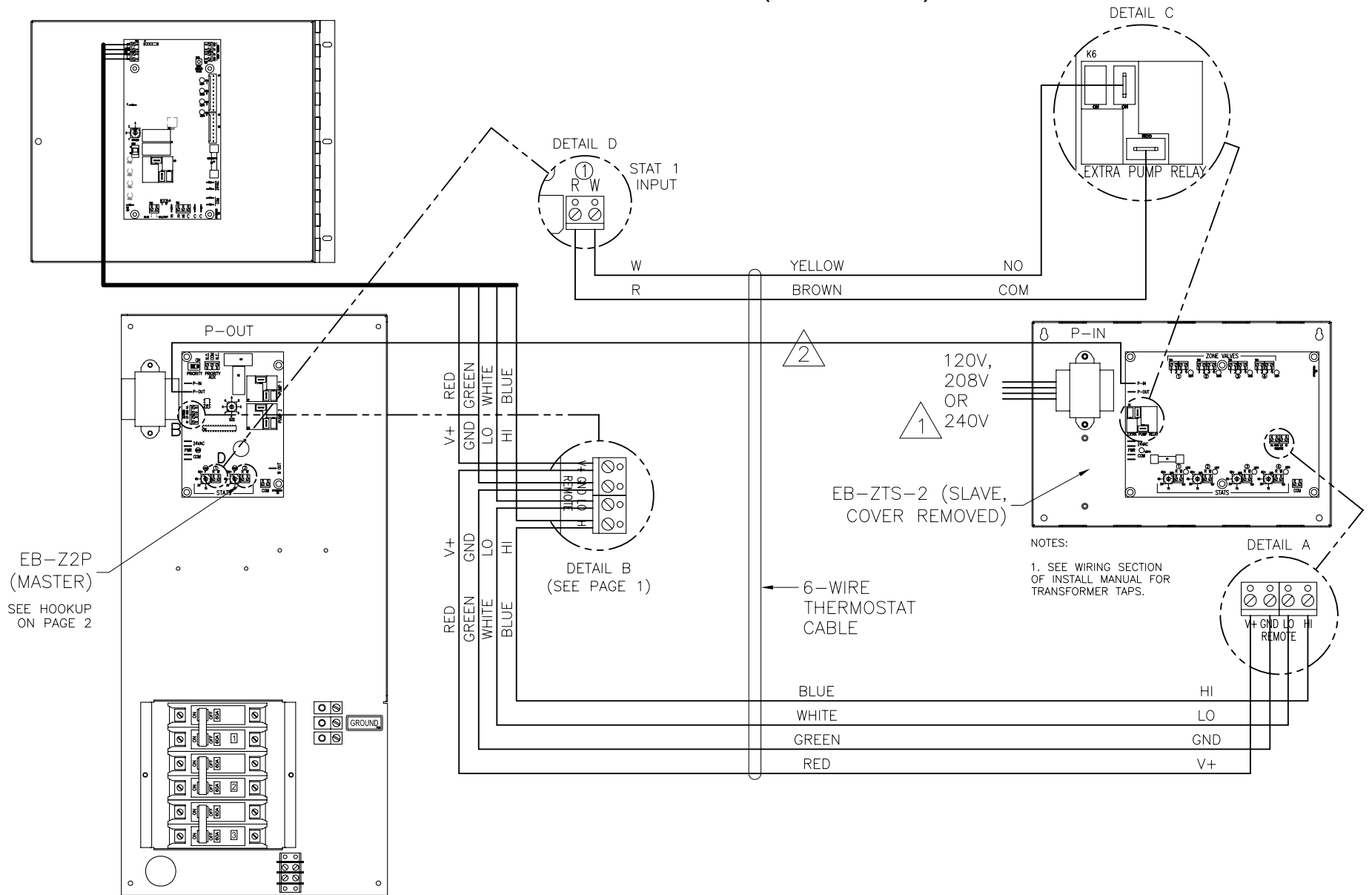

NOTES:

1. SEE WIRING SECTION OF INSTALL MANUAL FOR TRANSFORMER TAPS.
2. MUST HAVE P-OUT TIED TO P-IN.

TWO ZONE CONTROLLERS (OPTION C)

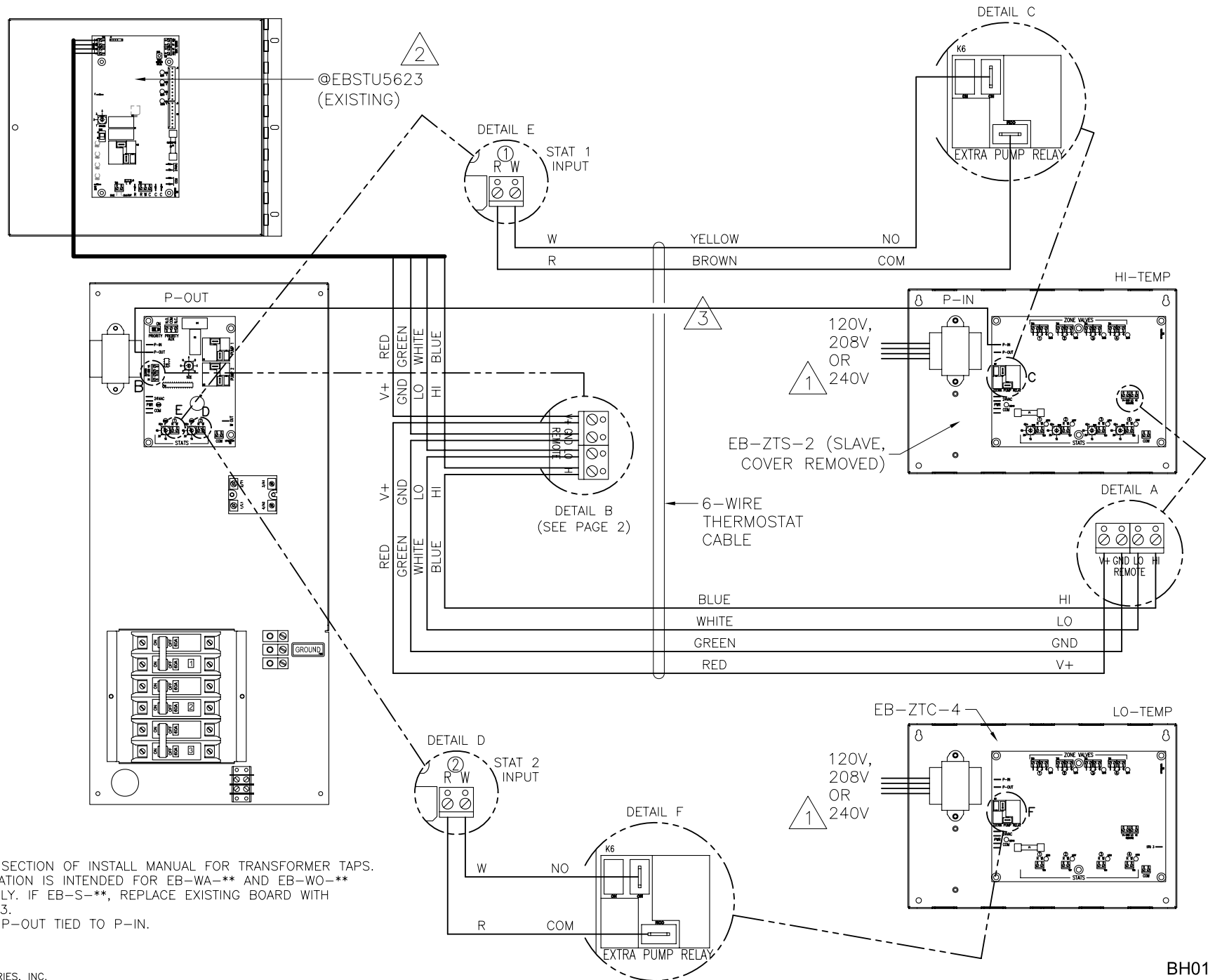

NOTES:

1. SEE WIRING SECTION OF INSTALL MANUAL FOR TRANSFORMER TAPS.
2. THIS APPLICATION IS INTENDED FOR EB-WA-** AND EB-WO-** MODELS ONLY. IF EB-S-**, REPLACE EXISTING BOARD WITH @EBSTU5623.
3. MUST HAVE P-OUT TIED TO P-IN.

FOUR-ZONE HOOKUP

NOTES:

1. SHOWN IS HOOK-UP FOR 3 DIFFERENT ZONE VALVE TYPES. TYPICALLY ALL ZONE VALVES ON AN INSTALLATION WILL BE THE SAME TYPE.

2. BASIC STAT SHOWN, SOME ELECTRONIC SLAB STATS MAY BE 3-WIRE. THIRD WIRE IS CONNECTED TO THE "SYSTEM COMMON" TERMINAL BLOCK.

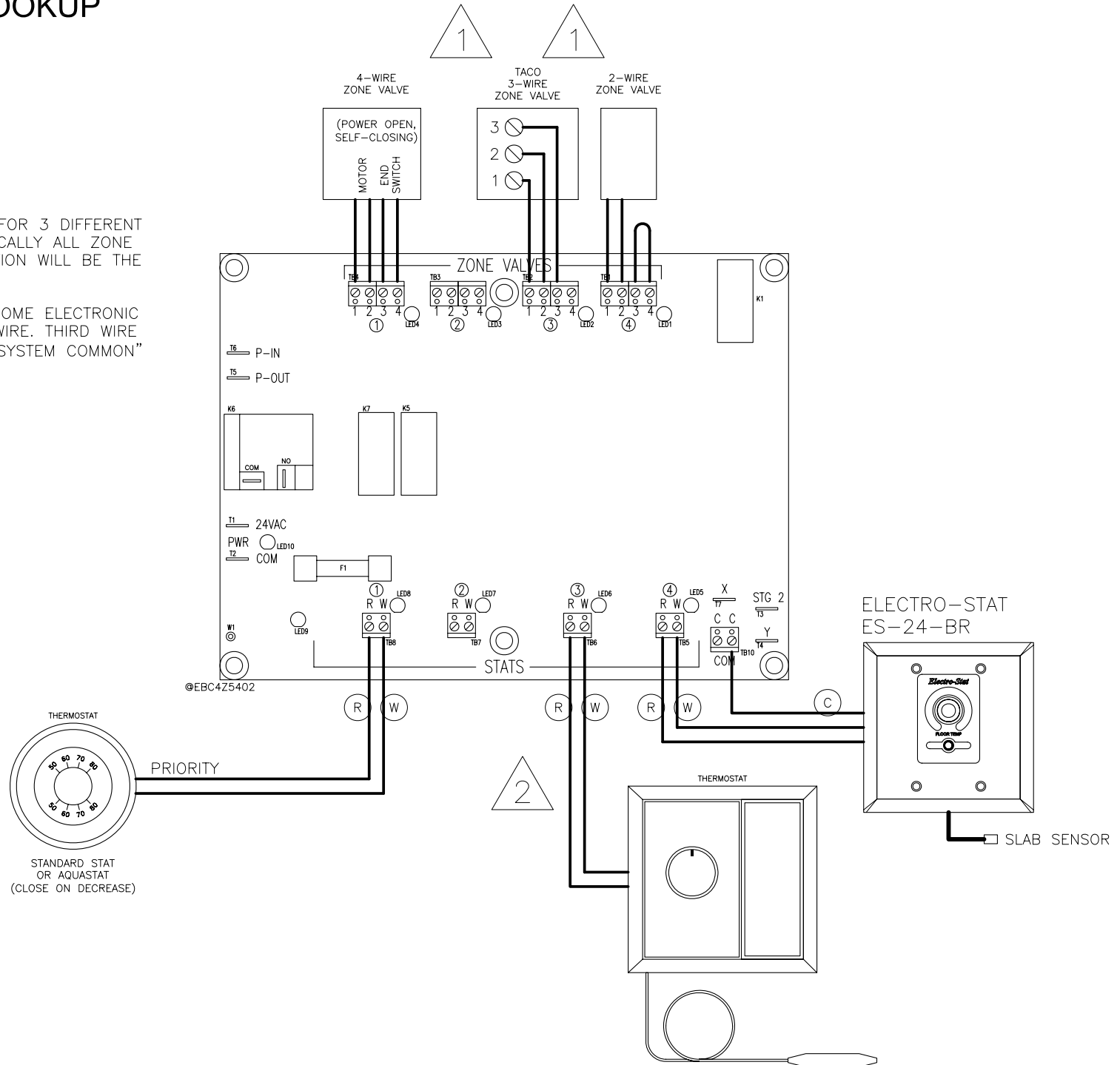

Electro Industries, Inc. Limited Product Warranty

Effective October 1, 2007

Electro Industries, Inc. warrants to the original owner, at the original installation site, for a period of two (2) years from date of installation, that the product and product parts manufactured by Electro Industries are free from manufacturing defects in materials and workmanship, when used under normal conditions and when such product has not been modified or changed in any manner after leaving the plant of Electro Industries. If any product or product parts manufactured by Electro Industries are found to have manufacturing defects in materials or workmanship, such will be repaired or replaced by Electro Industries. Electro Industries shall have the opportunity to directly, or through its authorized representative, examine and inspect the alleged defective product or product parts. Electro Industries may request that the materials be returned to Electro Industries at the owner's expense for factory inspection. The determination as to whether product or product parts shall be repaired, or in the alternative replaced, shall be made by Electro Industries or its authorized representative. Electro Industries will cover reasonable labor costs to repair defective product or product parts for ninety (90) days after installation.

TWENTY YEAR (20) LIMITED WARRANTY ON BOILER ELEMENTS AND VESSELS

Electro Industries, Inc. warrants that the boiler elements and vessels of its products are free from defects in materials and workmanship through the twentieth year following date of installation. If any boiler elements or vessels are found to have a manufacturing defect in materials or workmanship, Electro Industries will replace them.

TWENTY YEAR (20) LIMITED WARRANTY ON SPIN FIN ELEMENTS

Electro Industries, Inc. warrants that the spin fin elements of its products are free from defects in materials and workmanship through the twentieth year following date of installation. If any spin fin elements are found to have a manufacturing defect in materials or workmanship, Electro Industries will replace them.

FIVE YEAR (5) LIMITED WARRANTY ON OPEN WIRE ELEMENTS

Electro Industries, Inc. warrants that the open wire elements of its products are free from defects in materials and workmanship through the fifth year following date of installation. If any open wire elements are found to have a manufacturing defect in materials or workmanship, Electro Industries will replace them.



ELECTRO INDUSTRIES, INC.
2150 West River Street, PO Box 538, Monticello, MN 55362
763.295.4138 • 800.922.4138 • fax 763.295.4434
sales@electromn.com • www.electromn.com

THESE WARRANTIES DO NOT COVER:

1. Costs for labor for removal and reinstallation of an alleged defective product or product parts, transportation to Electro Industries, and any other materials necessary to perform the exchange, except as stated in this warranty. Replacement material will be invoiced to the distributor in the usual manner and will be subject to adjustment upon verification of defect.
2. Any product that has been damaged as a result of being improperly serviced or operated, including, but not limited to, the following: operated with insufficient water or airflow, allowed to freeze, subjected to flood conditions, subjected to improper voltages or power supplies, operated with airflow or water conditions and/or fuels or additives which cause unusual deposits or corrosion in or on the product, chemical or galvanic erosion, improper maintenance or subject to any other abuse or negligence.
3. Any product that has been damaged as a result of natural disasters, including, but not limited to, the following: lightning, fire, earthquake, hurricanes, tornadoes or floods.
4. Any product that has been damaged as a result of shipment or handling by the freight carrier. It is the receiver's responsibility to claim and process freight damage with the carrier.
5. Any product that has been defaced, abused, or suffered unusual wear and tear as determined by Electro Industries or its authorized representative.
6. Workmanship of any installer of the product. This warranty does not assume any liability of any nature for unsatisfactory performance caused by improper installation.
7. Transportation charges for any replacement part or component, service calls, normal maintenance; replacement of fuses, filters, refrigerant, etc.

CONDITIONS AND LIMITATIONS:

1. If at the time of a request for service the original owner cannot provide an original sales receipt or a warranty card registration then the warranty period for the product will have deemed to begin thirty (30) days after the date of manufacture and **NOT** the date of installation.
2. The product must have been sold and installed by a licensed electrical contractor, a licensed plumbing contractor, or a licensed heating contractor.
3. The application and installation of the product must be in compliance with Electro Industries' specifications as stated in the installation and instruction manual, and all state and federal codes and statutes. If not, the warranty will be null and void.
4. The purchaser shall have maintained the product in accordance with the manual that accompanies the unit. Annually, a qualified and licensed contractor must inspect the product to assure it is in proper working condition.
5. All related heating components must be maintained in good operating condition.
6. All lines must be checked to confirm that all condensation drains properly from the unit.
7. Replacement of a product or product part under this limited warranty does not extend the warranty term or period.
8. Before warranty claims will be honored, Electro Industries shall have the opportunity to directly, or through its authorized representative, examine and inspect the alleged defective product or product parts. Remedies under this warranty are limited to repairing or replacing alleged defective product or product parts. The decision whether to repair or, in the alternative replace, products or product parts shall be made by Electro Industries or its authorized representative.

THESE WARRANTIES DO NOT EXTEND TO ANYONE EXCEPT THE ORIGINAL PURCHASER AT RETAIL AND ONLY WHEN THE PRODUCT IS IN THE ORIGINAL INSTALLATION SITE. THE REMEDIES SET FORTH HEREIN ARE EXCLUSIVE.

ALL IMPLIED WARRANTIES, INCLUDING WARRANTIES OF MERCHANTABILITY AND FITNESS FOR A PARTICULAR PURPOSE, ARE HEREBY DISCLAIMED WITH RESPECT TO ALL PURCHASERS OR OWNERS. ELECTRO INDUSTRIES, INC. IS NOT BOUND BY PROMISES MADE BY OTHERS BEYOND THE TERMS OF THESE WARRANTIES. FAILURE TO RETURN THE WARRANTY CARD SHALL HAVE NO EFFECT ON THE DISCLAIMER OF THESE IMPLIED WARRANTIES.

ALL EXPRESS WARRANTIES SHALL BE LIMITED TO THE DURATION OF THIS EXPRESS LIMITED WARRANTIES SET FORTH HEREIN AND EXCLUDE ANY LIABILITY FOR CONSEQUENTIAL OR INCIDENTAL DAMAGES RESULTING FROM THE BREACH THEREOF. SOME STATES DO NOT ALLOW THE EXCLUSION OR LIMITATION OF INCIDENTAL OR CONSEQUENTIAL DAMAGES, SO THE ABOVE LIMITATIONS OR EXCLUSIONS MAY NOT APPLY. PRODUCTS OR PARTS OF OTHER MANUFACTURERS ATTACHED ARE SPECIFICALLY EXCLUDED FROM THE WARRANTY.

THIS WARRANTY GIVES YOU SPECIFIC LEGAL RIGHTS, AND YOU MAY HAVE OTHER RIGHTS WHICH VARY UNDER THE LAWS OF EACH STATE. IF ANY PROVISION OF THIS WARRANTY IS PROHIBITED OR INVALID UNDER APPLICABLE STATE LAW, THAT PROVISION SHALL BE INEFFECTIVE TO THE EXTENT OF THE PROHIBITION OR INVALIDITY WITHOUT INVALIDATING THE REMAINDER OF THE AFFECTED PROVISION OR THE OTHER PROVISIONS OF THIS WARRANTY.