

Air Vents

DESCRIPTION

The Cash Acme Air Vents are for use in heating systems to vent air trapped within the circulating water.

The Cash Acme Air Vents are available in 1/8" and 1/4" high capacity sizes.

FEATURES AND BENEFITS

High quality brass body with a nickel plated finish:
Durable construction for long lasting service.

Economical and easy to install:
Saves money and time!

Wide range of sizes:
Fits a variety of heating systems.

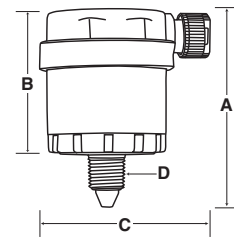
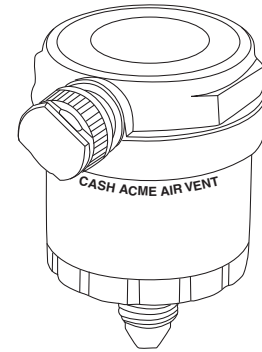

Working Pressure: 150 psi

Item	A	B	C	D
24090	1-15/16"	1-21/32"	1-7/8"	1/8" NPT
24091	1-15/16"	1-21/32"	1-7/8"	1/4" NPT

TYPICAL INSTALLATION

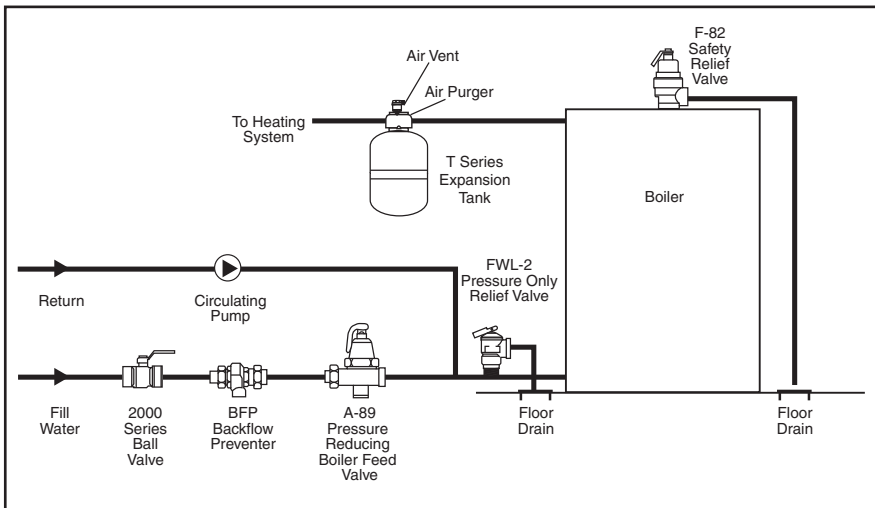

SPECIFICATION DATA

Performance:

Working pressure 90 -150 psi (or refer to chart)

Service Water

Materials:

Body: Brass

CONNECTIONS

Threaded (NPT) 1/8" and 1/4"