

OVERVIEW OF CALEFFI SNOW MELT CONTROL



Ice and Snow Detector



Holding sleeve for slab sensor

Slab sensor – Patented technology uses PTC for detecting ice & snow condition



Retrofit adapter ring fits older style competitive holding sleeve



Outdoor air sensor

Gutter sensor with 20' cable



Ice and Snow Detector

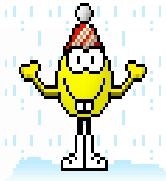

Sensor will time test **temperature** <> moisture coordinates every 25 min. Once melt conditions are met, contacts close for min heat time, or until melt conditions cease.

PTC Sensor won't contaminate



To slab PTC sensor
To alarm
To heat source or pump relay

OVERVIEW OF DISPLAY

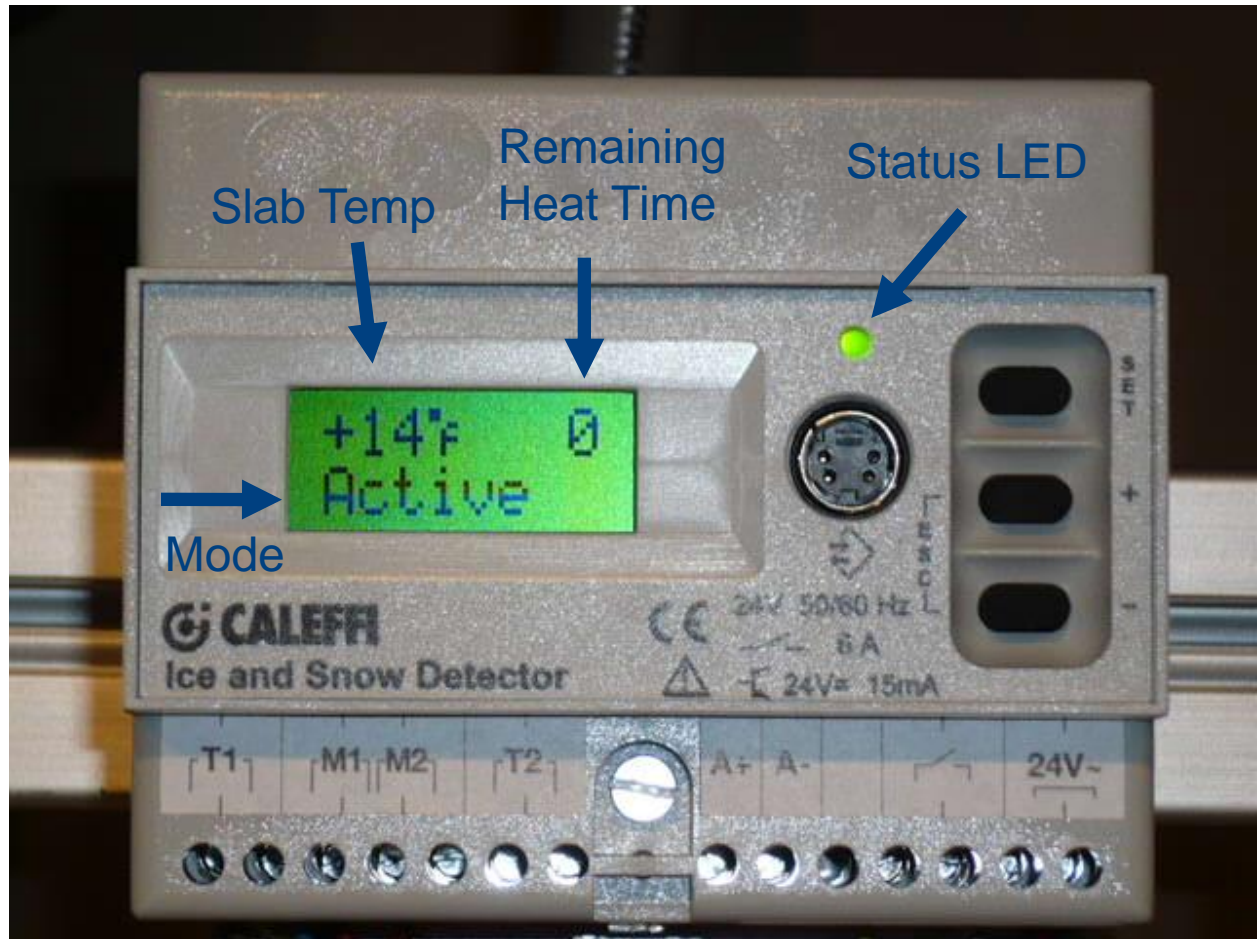

Installation

Transformer supplied with unit **MUST be used.**

Controller checks for input voltage before performing a moisture check. If voltage exceeds +/- 10% from nominal 24 VAC the unit will not operate

Typical 24 VAC transformers deliver 27+ VAC when not loaded

Caleffi's transformer has been specifically manufactured to provide proper operating voltages.

On the primary side, 128 VAC is the maximum allowable voltage to produce an acceptable voltage on the secondary side using the Caleffi supplied transformer



Wiring

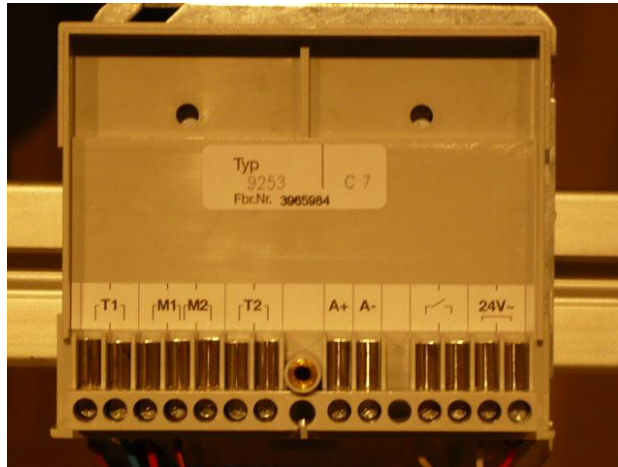

Built in DIN rail mounting.

Control can be pulled off from base for easier access to terminals. Loosen cover screw and pivot downward.

Wiring diagram for 1-sensor

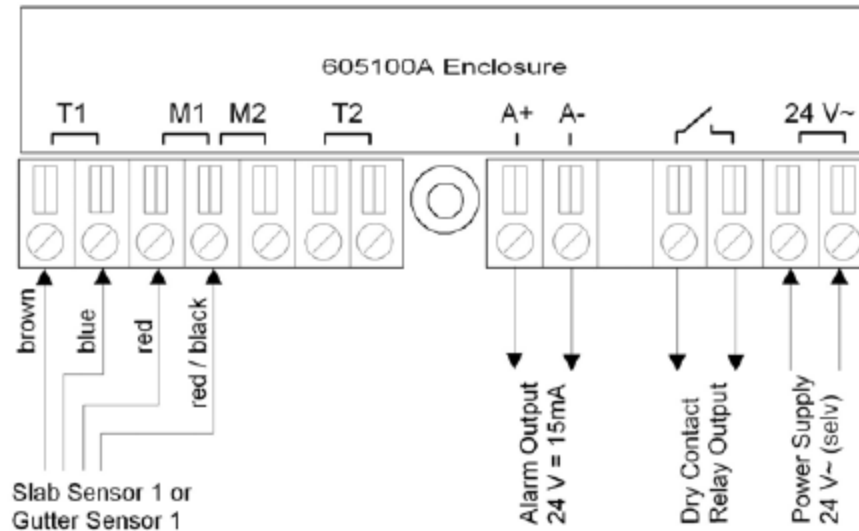

Sensor Installation

Must be mounted level

Away from over hangs!

White plug simulates sensor top, flush to concrete surface

Use conduit for sensor wire (this example used PAP tubing for sensor wire)



Principle of Operation

- **The Control is continuously monitoring the sensor temperature.**
- **When the slab temperature drops within the “Active window” the unit will check for moisture every 25 minutes.**
- **It does this by applying a known amount of power to the sensor to melt any ice or snow that is present.**
- **After a set amount of time (1-3 minutes) the control checks the final temperature of the sensor.**
- **By knowing the initial temperature, the final temperature and the amount of power delivered, the control calculates the amount of moisture present.**
- **The control then displays this value in a number between 1-99 (1 being dry, 99 being flooded).**
- **This is a simplified description, the control is actually averaging the final resistance (temperature) every 5 seconds.**

Caleffi Snow Melt Control States

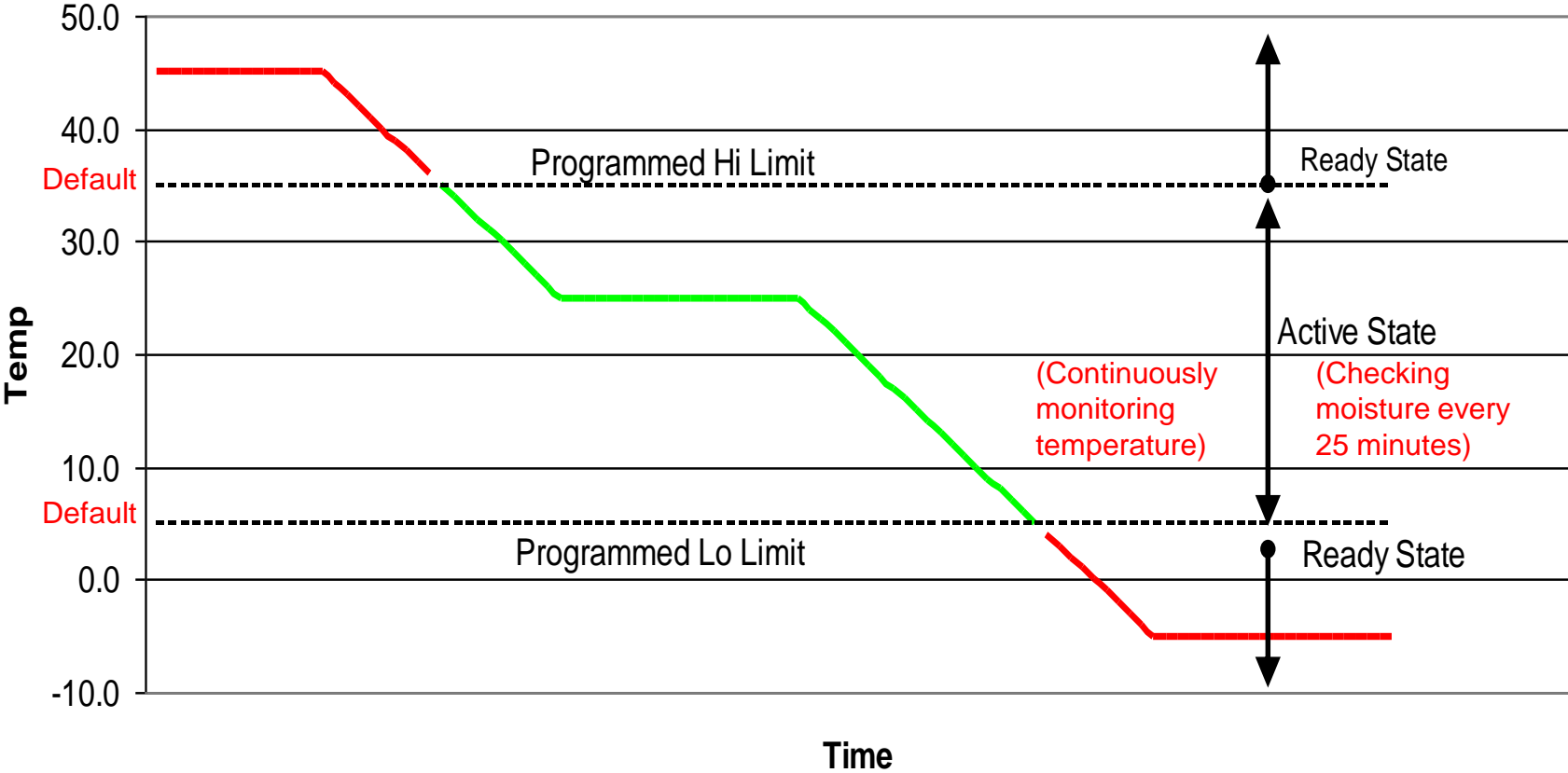

Principle of Operation

Operating Modes

- **Ready (Slab temperature is above warm weather cut out)**
- **Active (Slab temperature is within High and low limits, unit is checking for moisture every 25 minutes)**
- **Heating# (Relay is closed for minimum run time, 120 min factory default, adjustable 30-600)**
- **Heating (Occurs after minimum run time if slab temperature is still within limits and moisture present. Remember: this differs from above as there is no '#').**
- **Heating* (Heating to achieve idle temp)**
- **Error (Must go to “Show Status” menu to see error code)**

Digital Snow Melt

Min Heating time set to 40 Minutes

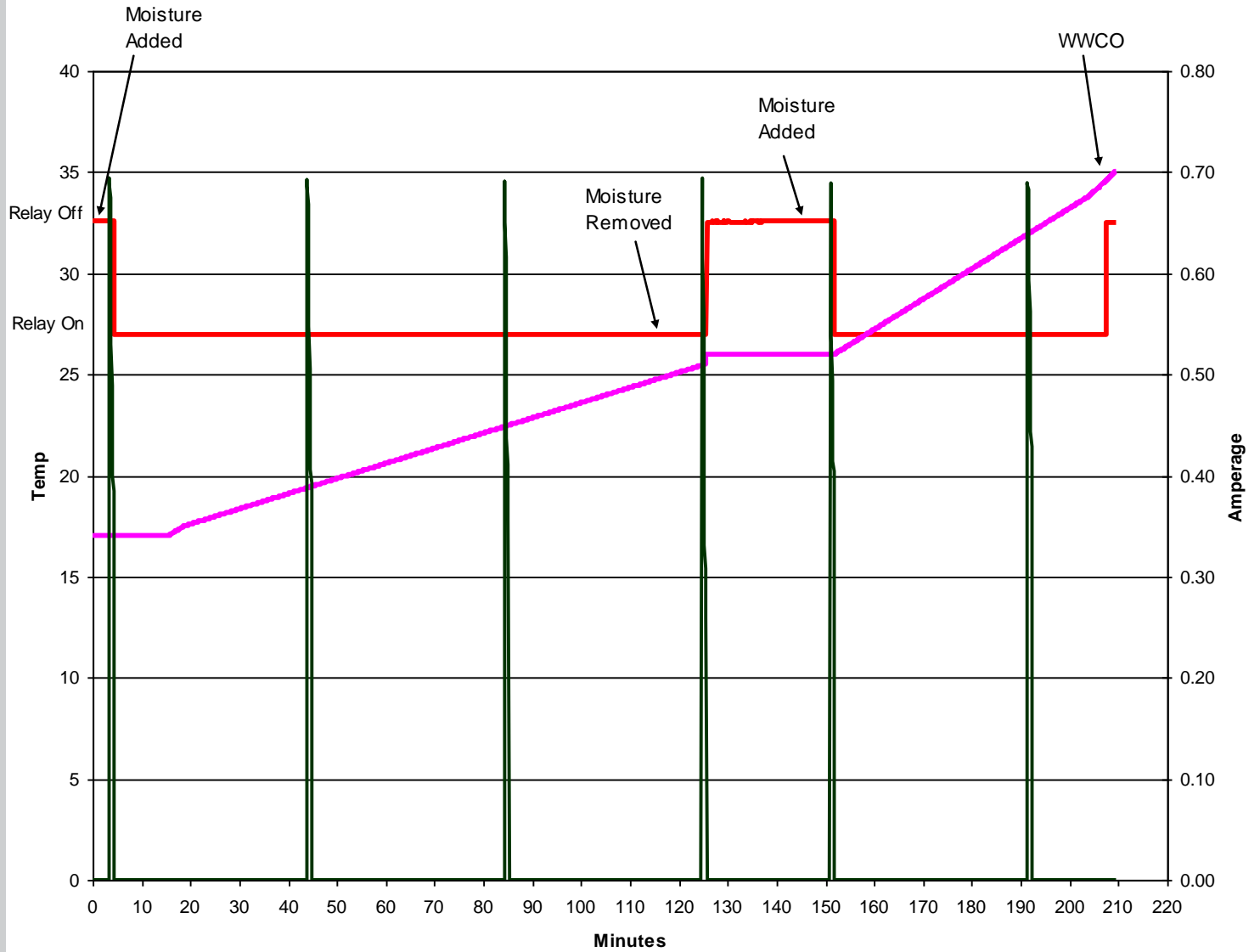

— Relay Output — Sensor Temp — Sensor Current

Basic Programming

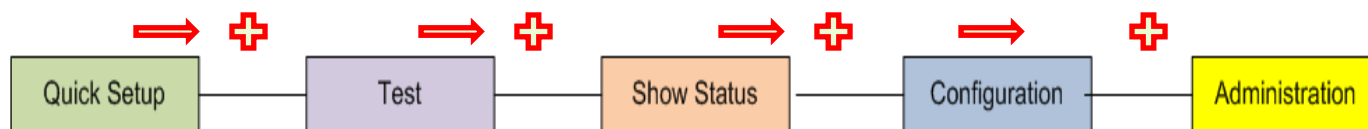

Advance to next main menu with  key.

Quick Setup

Allows configuration setup to meet most applications

Test

Allows to test each function

Show Status

View recent and current information

Configuration

Allows advanced configuration setup such as two sensor operation or idle mode

Administration

Allows restoring defaults, change of language and units of measure

Basic Programming

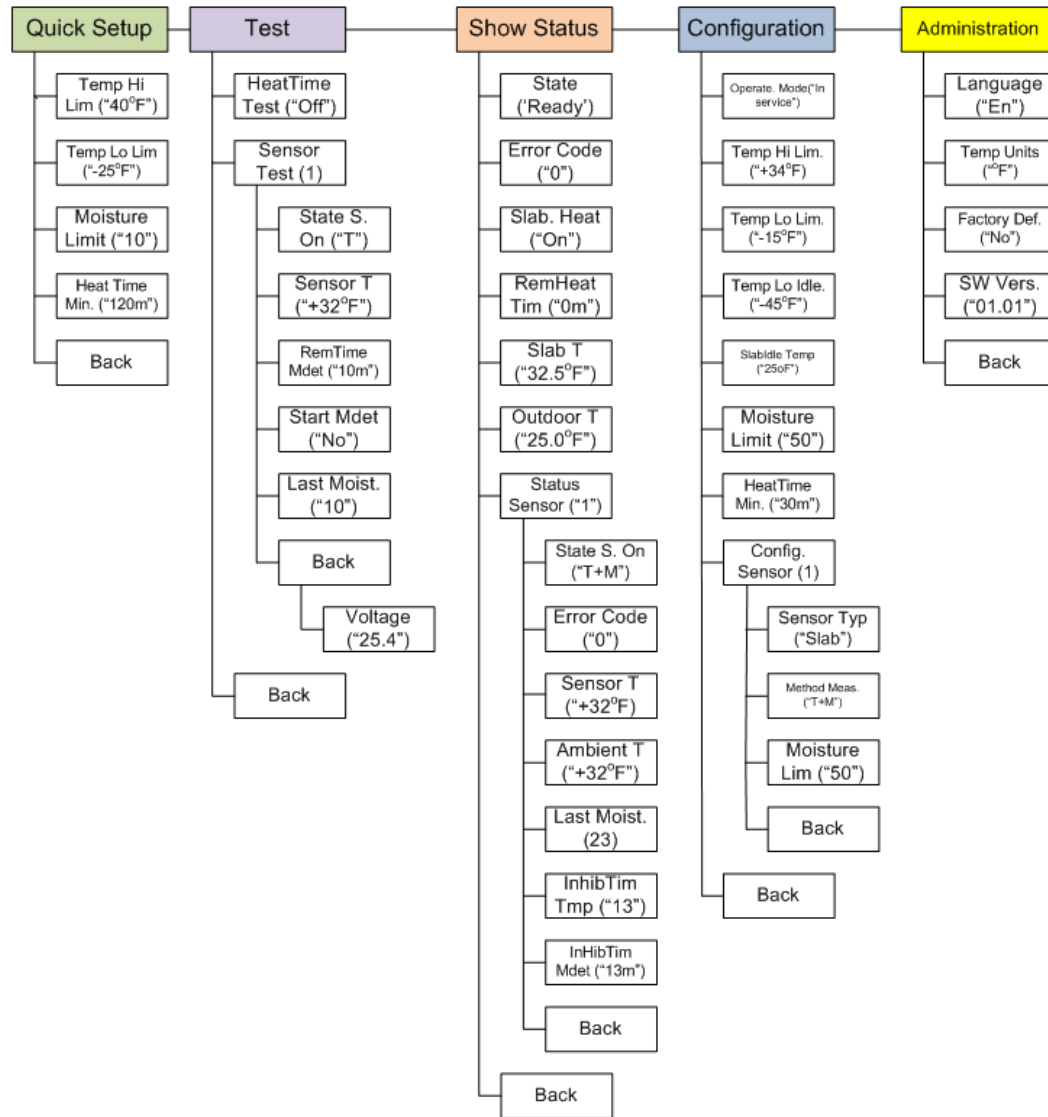

Quick Setup Menu

Cover 90% of applications
Programs the 4 most
important values



Test Menu

Special note: After a moisture detection, the temp is locked on the main display for 10-15 minutes to allow sensor head to cool down to actual slab temp.

And: Multiple manually started moisture detection cycles will skew..and will come back lower with each successive check. An error on display after starting a moisture detection indicates you started this during the inhibit time.

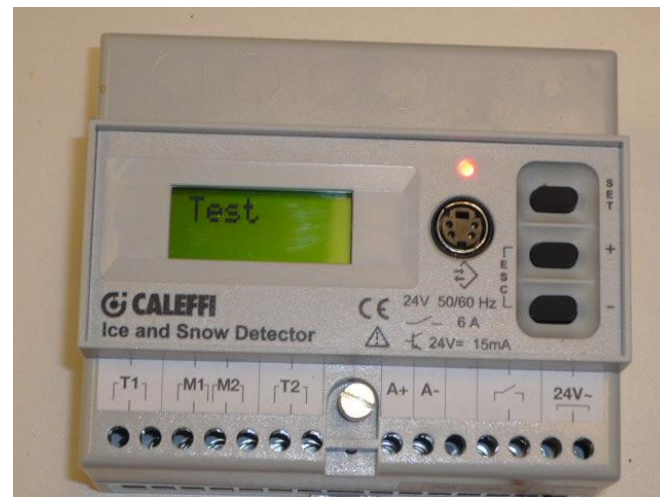
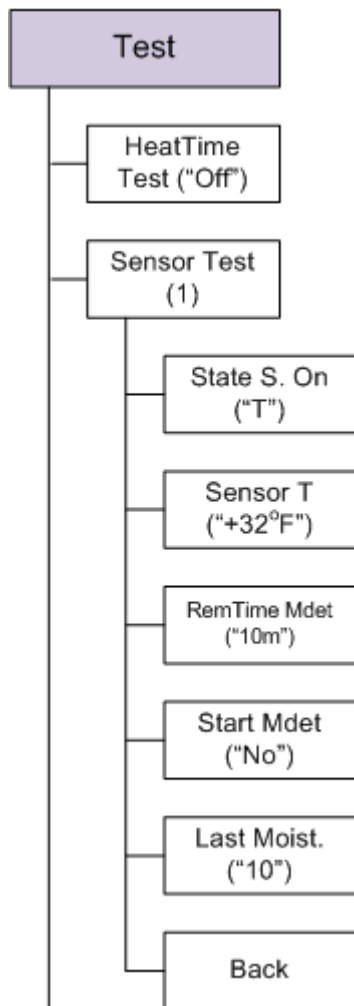

Manually activate heat output relay for minimum heating time. **You can activate and walk away, as it will complete the heat cycle and return to the programmed function. An empty box on the display means it is not performing the heat time test.**

Select sensor 1 or 2 to enter testing submenu.

Displays operating State of selected sensor as On or Off
T=Temp., M=Moist., T+M=Temp. & Moist.

Displays temperature of selected sensor (actual temperature)

This may say "InhibitTime" instead.

Displays remaining time till next moisture detection (0 to 600m)
Detection begins at end of min heating time

Manually starts moisture detection cycle by selecting Yes
Last Moist = '1' indicates multiple starts here, so Reset to factory defaults or wait at least 1 hr for sensor to 'cool' off. Avoid back to back manually started detection cycles.

Displays last moisture detected (5 to 95.)

5 is dry- no moisture detected

Returns to Sensor Test submenu (press Set)

Test Menu (continued)

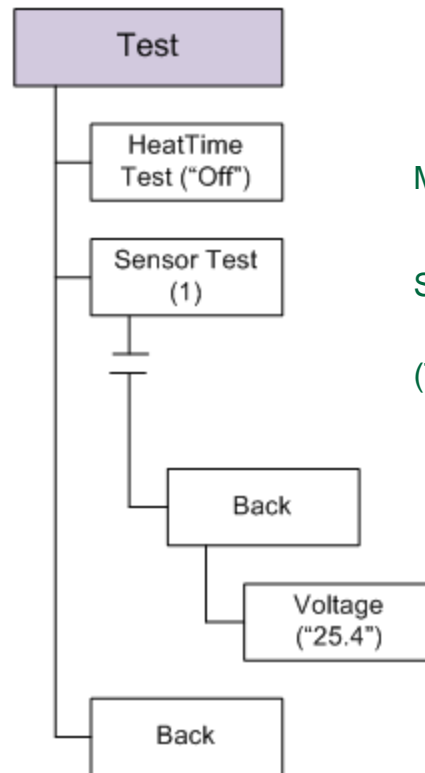
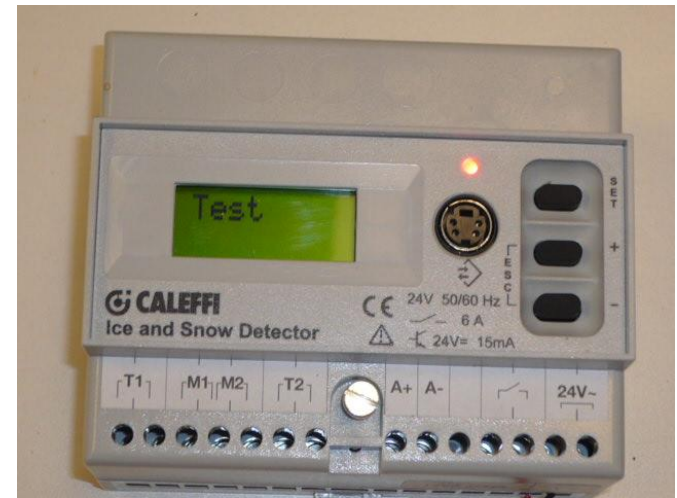

Manually activate heat output relay for minimum heating time.

Select sensor 1 or 2 to enter testing submenu.

(Test submenu continued from previous slide)

Returns to Sensor Test submenu (press Set)

Displays current input voltage

Returns to Test submenu (press Set)

Show Status Menu

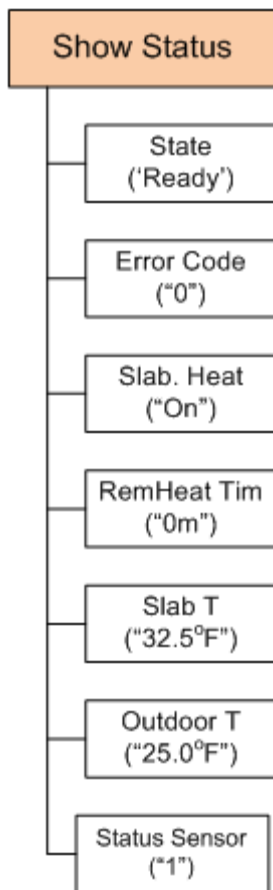

Displays detector operating state:
Ready, Inactive, Off, Reset, Active, Heating or Error

Displays detector error code:
0 = no error, see detector error code chart

Displays slab heat state: On Off

Displays remaining heating time:
0 if Heating Demand or Slab Heating Off

Displays effective Slab temperature

Displays recent outdoor air temperature (in Idle Mode)

Select sensor 1 or 2 to enter submenu

Note: Show status menu is mostly redundant to Test Menu.

Show Status Menu (continued)

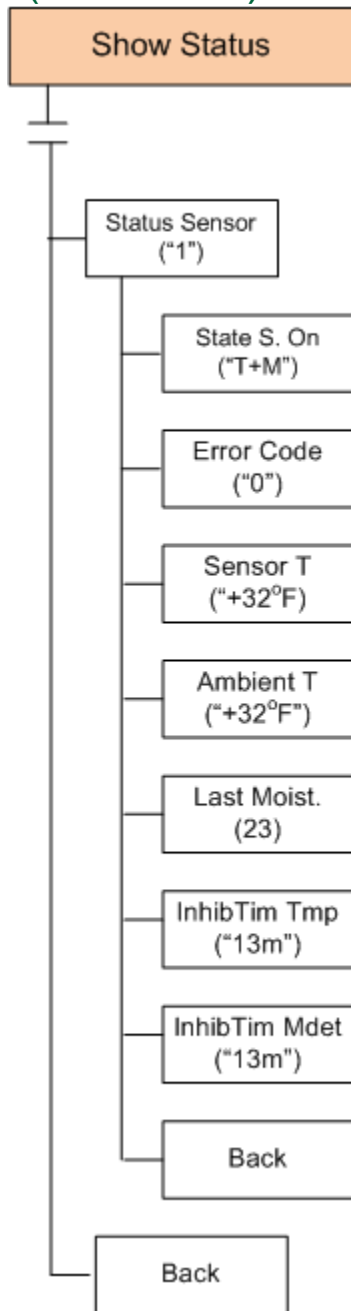

Displays selected sensor operating state as On or Off:
T=Temp., M=Moist., T+M=Temp. & Moist.

Displays sensor error code:

0 = no error, see sensor error code chart

Displays moisture sensor temperature of selected sensor

Displays outdoor air temperature for selected sensor:
Maintain last valid amb temp during inhibit period

Displays last moisture detection:

5 to 95 (--x = no data was recorded). After a moisture detection, the unit will lock the temp on the display.

Displays remaining inhibit time before temp. update:

0 to 15 minutes

Displays remaining inhibit time before next moisture detection cycle:
0 to 600 minutes

Returns to Status Sensor submenu (press Set)

Returns to Show Status submenu (press Set)

Configuration Menu (adjusting parameters)

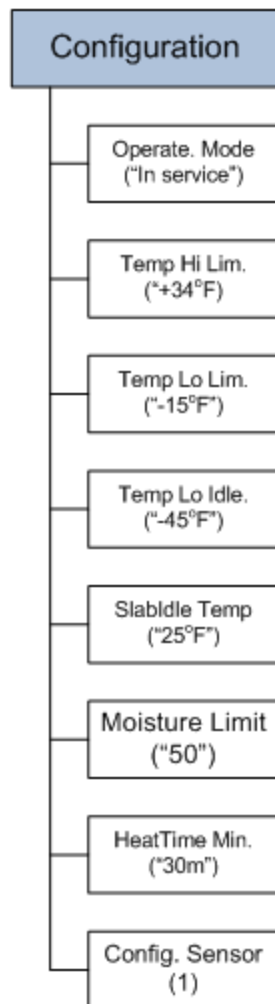

Displays operating mode:

In service, out of service, in service-idle mode

Adjust & Set High Temperature Limit (WWCO):

+26°F to +40°F; factory default=35°F

Setting a value here overrides value set in Quick Setup

Adjust & Set Low Temperature Limit (CWCO):

-25°F to +25°F; factory default=5°F

Setting a value here overrides value set in Quick Setup

Adjust & Set Low Temperature Limit for Idle mode:

-50°F to +25°F; sensed by outside air sensor

Adjust & Set Slab Idle Temperature for Idle mode:

-25°F to +40°F; sensed by slab sensor

Adjust & Set Moisture Limit in increments of 5:

5 to 95

Adjust & Set the minimum heating time in 10 min. increments:

30 to 600 minutes; factory default=120 min.

Setting a value here overrides value set in Quick Setup

Configures selected sensor:

select sensor 1 or 2 to enter submenu

Configuration Menu (Continued)

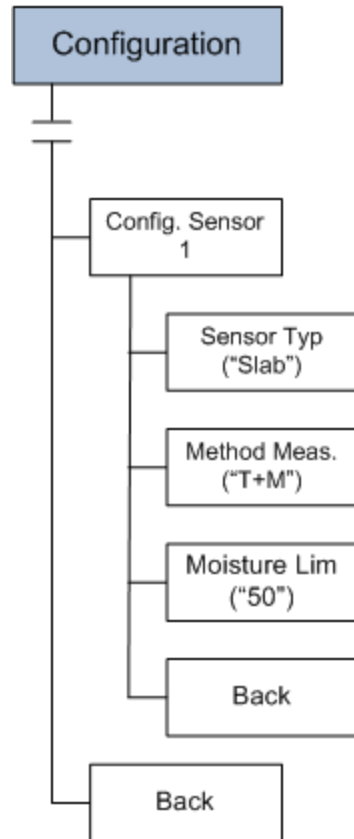

Configures selected sensor:
select sensor 1 or 2 to enter submenu

Select sensor type:
Slab=Slab, Gutt=Gutter, or OAT=Outdoor Air Temp (Idle)

Select measure method:
T=Temp only, M=Moisture only, or T+M=Temp & Moisture
T works only for OAT sensor; T+M for Slab & gutt

Adjust & Set Moisture Limit in increments of 5:
5 to 95. Set to -x if only one sensor is used.
Good rule of thumb- start with 20.

Setting a value here overrides value set in Quick Setup
Returns to Configuration sensor submenu (press Set)

Returns to Configuration sensor submenu (press Set)
In summary-No need to use Config Menu unless using 2 sensors or idle mode.

Administration Menu

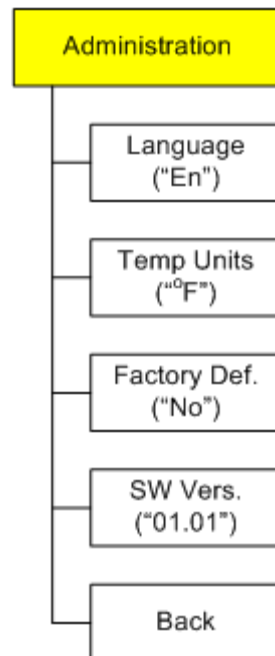
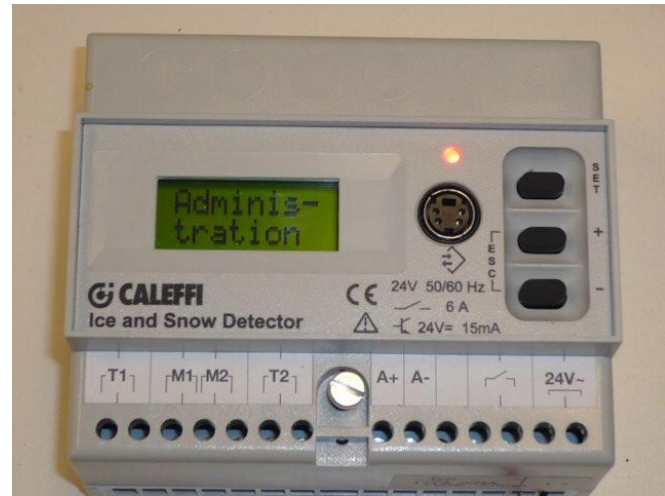

Select & Set Language:

En=English, Fr=French. Default=English

Select & Set Temperature Units:

°f=Fahrenheit, °c=Celsius. Default=°F

Restores parameters to Factory Default settings:

No or Yes

Displays Software versions:

Returns to Administration submenu (press Set)

Detector Error Codes

Error Code	Description
1	Slab / gutter temperature cannot be determined; each active temperature sensor reports temperature measurement failure. Potential cause: <ul style="list-style-type: none">• See Sensor error code 1 (slab / gutter sensors only)• Detector internal failure.
2	Outdoor temperature required but not available (Idle Mode only); outdoor temperature sensor reports temperature measurement failure. Potential cause: <ul style="list-style-type: none">• See Sensor error code 1 (outdoor air temperature sensor only)• Detector internal failure.
4	Moisture cannot be determined; each active moisture sensor reports temperature measurement and / or moisture detection failure. Potential cause: <ul style="list-style-type: none">• See Sensor error codes 2 or 4, respectively.• Temperature loop of affected sensor faulty.• Detector internal failure.
8	Configuration problem. Potential cause: <ul style="list-style-type: none">• No sensor defined for temperature measurement.• No sensor defined for moisture detection.• Idle Mode enabled but no valid sensor defined for outdoor air temperature measurement.

Error codes are of limited use but generally give an idea of what to look for when troubleshooting.

Sensor Error Codes

Error Code	Description
1	Temperature sensor faulty. Potential cause: <ul style="list-style-type: none">• Sensor cable damaged (open loop or short circuit).• Temperature detector inside the sensor faulty.• Detector internal failure.
2	Supply voltage prior to start of the last moisture detection cycle not within the defined voltage range; detection cycle has not been started. Potential cause: <ul style="list-style-type: none">• Detector supply voltage more than + 10 % above rated voltage.• Detector supply voltage less than - 15 % below rated voltage.• Detector internal failure.
4	Most recent moisture detection faulty. Potential cause: <ul style="list-style-type: none">• Supply voltage too low during last moisture detection cycle• Sensor cable damaged (open loop or short circuit)• Moisture detector inside the sensor faulty• Detector internal failure
8	Internal failure during most recent moisture detection. Potential cause: <ul style="list-style-type: none">• Configuration problem• Detector internal failure.

NOTE: The control will sum the error codes if more than one is present.

More on Error Codes

Remember:

Error codes are of limited use. They provide a general idea of what to look for when troubleshooting.

Usually errors are due to:

Input Voltage exceeding 26.4 Volts, which can be checked under the Test Menu/Sensor Test/Back pressing the + button.

Damaged sensors or sensor wires.

Most Common Reason for Technical Calls

The contractor doesn't understand how the unit operates.

Explain how the unit operates: If the contractor is new to our product, it's usually best to start by explaining the principle of operation (even though it's written right in the instructions). The unit has a high temperature limit, a low temperature limit, a sensitivity setting (the lower the number the more sensitive it is) and a minimum run time. When the temperature of the slab drops between the max and min temperatures, the unit will go out every 25 minutes and look for moisture. If it finds moisture, the unit displays "heating #", and the relay will close for the minimum run time regardless of what the slab temperature is. After the minimum run time, the unit will look at the slab temperature, if it is above the maximum temperature it will go into "ready" mode. If the slab temperature is still within the max and min, the unit will do a moisture check. If moisture is found, the unit will keep the relay closed and the display shows "heating" (the # is dropped to show it is not in the first heat cycle). If the temperature of the slab increases above the maximum temperature during the second heat cycle, the control will open the relay and move back to the "ready" state.

Contractors sometimes think that our max and min temps are the slab temps that the control will maintain. When they program it this manner, the control will not fire once the slab temp drops below the min temperature. Also note that sometimes they will have this window too narrow, say 35 degrees for high and 32 degrees for low, and that's too narrow to be useful.

The contractor is not using the Caleffi supplied transformer

There is a hidden screen in the test menu which shows the input voltage. Use this to verify what the contractor is telling you. Many times contractors simply pull 24 VAC from the relay box that they are using. The Caleffi transformer will provide correct voltage to the control even if the input voltage is as high as 128 VAC. The detector needs accurate voltage input to return accurate moisture readings. The voltage can not be outside 24 VAC + or - 10% range.



The minimum run time is not long enough.

A large percentage of our calls involve a snow melt system on a driveway with pavers. The tubing is usually put into a concrete slab, then a layer of sand, then the pavers. This set up requires a very long run time before the surface of the pavers exceeds 32 degrees. Our default settings will not work with pavers. The minimum run time must be increased to at least 240 minutes, sometimes more depending upon the construction, water temp, tube spacing, etc. So, when in doubt- extend the run time. It is very important to set this to when a melt will occur.

The unit will always run for the minimum run time setting for the first heat cycle (Heating# State), regardless of the slab temperature. It does not moisture check during the minimum run time, but when that is finished and if the slab temperature is above the Temp Hi Limit, it will go back to the Ready State. If the slab temperature is not above the Temp Hi Limit, it will do a moisture check and if moisture is still detected, it will activate the second heat cycle (Heating State). If the temperature exceeds the Temp Hi Limit, then it will stop heating.

Error Code “0”

Many times the contractor will state that the control is displaying “error code 0”. There isn’t an “error code 0”. The “0” is the time remaining in heat mode. You will need to dig into the show status menu to display what the error code actually is.



User has mis-configured the unit

Reset to factory defaults: Another common problem is that the user will dig deep into the menus and change the settings so the unit will not function (i.e. put the unit into idle mode with only one sensor). If you suspect this has happened, reset the unit to factory defaults by going into the administration menu.

Mis-configuring usually occurs when it's the contractor's first job, or when adding a second sensor or setting up for idle mode. So, it is good just to start over, resetting to the defaults and go back into setup.

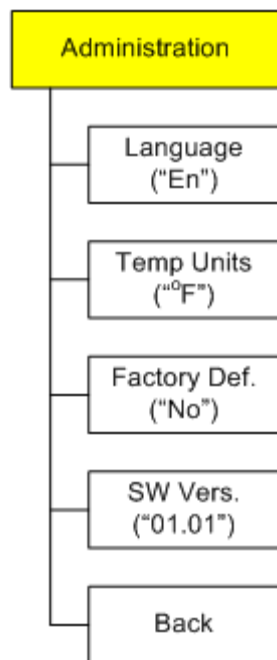

Hit set, then “+” to change to YES, then set, then “+” to confirm (System Reset)

User cannot configure idle mode

By default the control is not set up for idle mode. If the user simply changes the operating mode to idle in the configuration screen, the unit will produce an error because the 2nd sensor has not been configured. The second sensor must be configured to an OAT (also in the configuration menu).

CALEFFI OAT SENSOR MUST BE USED!*

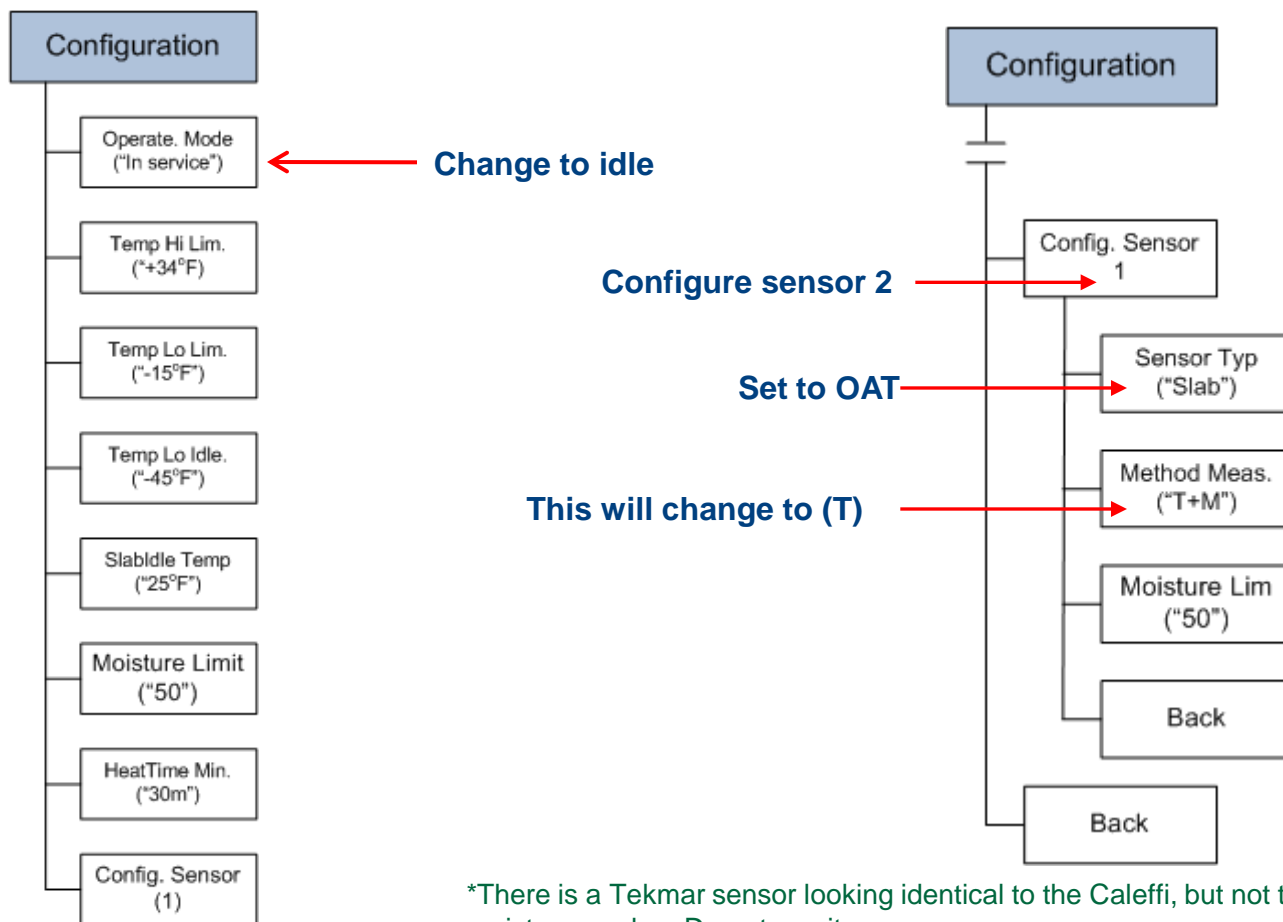

*There is a Tekmar sensor looking identical to the Caleffi, but not the right resistance value. Do not use it.

Check the sensor Resistance

Check the sensor: If the display continues with errors, check the resistance of the sensor. The sensor has a heating element and a thermistor. The thermistor will change its resistance as the temperature changes. The check can be easily done by dropping power to the unit, pull the control off from the base, then put the ohm meter probes right on the base contacts. The readings should be similar to the values listed below:

Slab sensor check:

To check the slab sensor after it is installed, the following resistance values can be measured at the end of the cable before connecting to detector enclosure.

Resistance values between **brown** and **blue** wires at corresponding slab temperatures:

- 6752 ohms at 23°F (-5°C) slab temp.
- 5634 ohms at 32°F (-0°C) slab temp.
- 4721 ohms at 39°F (4°C) slab temp.
- 3974 ohms at 46°F (8°C) slab temp.
- 3360 ohms at 53°F (12°C) slab temp.

Resistance value between **red** and **red/black** wires must be 25 to 40 ohms. This is for the heating element.

Snow Bridge

Snow bridges can occur because of two reasons, the moisture setting is too low and/or the minimum run time is too short. It is also can occur with pavers or multi-layer surfaces. When a dry powder snow falls on a slab that is slow to respond, the sensor heats up and melts the snow on it, if the sensitivity is not set low enough, the unit will not fire the boiler. Because the sensor is checking for snow every 25 minutes, this process can repeat and eventually build up a snow bridge or igloo over the sensor. This same thing can happen if the minimum run time is too short because the slab surfaces never goes above freezing. The most common sign of a snow bridge is a moisture reading of 1 even though the driveway has plenty of snow or ice.

Note: A heat time test fires the units just like it saw moisture. It will run for the minimum heat time and then it will either perform another moisture check or if the slab is warm, it will go back to the Ready state. In other words, you can initiate a heat time test and then walk away.

Can one detector operate 2 heating zones?

The Caleffi 605100A detector has 2 sensor inputs but only 1 dry contact relay output.

2 sensors provide separate temperature and moisture adjustments, trigger only one relay output, and decrease the time between moisture checks.

What is the connector on the face of the detector used for?

This is a special connection port for a serial connector to connect to a computer to use with the diagnostic software “Ice Monitor”. It opens a text file to record all parameters when connected to a PC. Call Caleffi for special cables. It is primarily a troubleshooting tool.

Is there a log for errors recorded?

Connecting to a PC with an interface cable to front connector on detector, all of the values are recorded and dropped into a text file. You have to remain connected to the PC.

How many error codes could you have?

Basically 4 or 5 are possible.