

# Dirt separator *DIRTCAL*

## 5462 series

cert. n° 0003  
ISO 9001



### Function

In heating and air conditioning control systems, the circulation of water containing impurities may result in rapid wear and damage to components such as pumps and control valves. It also causes blockages in the heat exchangers, heating elements and pipes, resulting in a lower thermal efficiency within the system. The dirt separator separates off these impurities, which are mainly made up of particles of sand and rust, collecting them in a large collection chamber, from which they can be removed even while the system is in operation. This device is capable of efficiently removing even the smallest particles, with extremely limited head loss. **Patented.**

### Product range

5462 Series DIRTCAL dirt separator with NPT threaded connections \_\_\_\_\_ sizes 3/4"–1 1/2"  
5462 Series DIRTCAL dirt separator with sweat connections \_\_\_\_\_ sizes 1" - 1 1/4"

### Technical specifications

Materials: - body: brass  
- dirt collection chamber: brass  
- top plug: brass  
- internal element: PA66G30  
- hydraulic seals: EPDM  
- drain cock: brass

Medium: water, glycol solution

Max percentage of glycol: 50%

Max working pressure: 150 psi (10 bar)

Temperature range: 32 to 230° F (0–110°C)

Particle separation capacity: to 5 µm

Connections: - main: 3/4", 1", 1 1/4", 1 1/2" NPT  
1" & 1 1/4" sweat  
- top: 1/2" F with plug  
- drain: 3/4" garden hose

### Dimensions

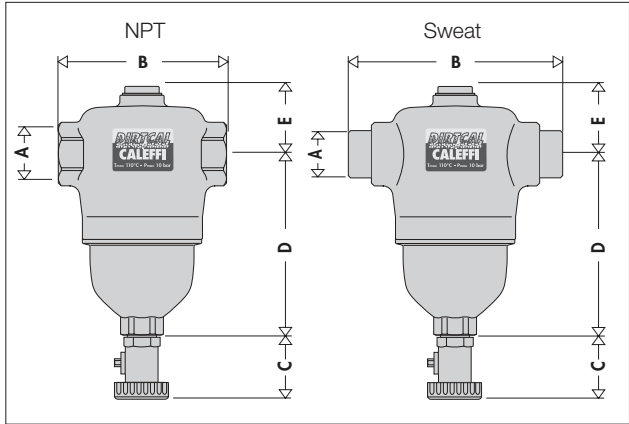

Code	A	B	C	D	E	Weight (lb)
546205A	3/4" NPT	4 5/16"	1"	5"	2"	4.2
546206A	1" NPT	4 5/16"	1"	5"	2"	4.2
546207A	1 1/4" NPT	4 7/8"	1"	6"	2"	5.3
546208A	1 1/2" NPT	4 7/8"	1"	6"	2"	5.3
546228A	1" Sweat	5 1/16"	1"	5"	2"	4.2
546235A	1 1/4" Sweat	5 3/16"	1"	5"	2"	4.2

## Operating principle

The dirt separator operating principle is based on the combined action of a number of physical phenomena.

The internal element (1) is composed of a set of radial reticular surfaces. The impurities in the water, on striking these surfaces, get separated, dropping into the bottom of the body (2) where they are collected.

In addition, the large internal volume of DIRTCAL slows down the flow speed of the medium thus helping, by gravity, to separate the particles it contains.

The collected impurities are discharged, even with the system running, by opening the drain cock (3) with the key (4) provided.

## Construction details

### Low head losses and performance maintained over time

The separating action performed by the dirt separator is based on using the internal element with reticular surfaces in place of the ordinary filter. The screen, by its nature, offers little resistance to the flow of medium while ensuring separation.

This occurs due to the particles colliding with the reticular surfaces and then settling, and not by filtration; an action by which the filter, over time, gets progressively clogged by the sludge it removes.

All this is to the benefit of performance, that is the high capacity to separate impurities and the low head losses that remain unaltered over time.



### Geometric structure and large dirt collection chamber

The geometrical structure of DIRTCAL means that, inside it, the flow speed is slowed down to help separate the particles of impurities.

The dirt collection chamber has the following features:

- It is located at the bottom of the device at such a distance from the connections that the collected impurities are not affected by the swirl of the flow through the screen.
- It is capacious enough to increase the amount of sludge stored and therefore decrease the frequency of emptying/discharging it (on the contrary to filters that need to be frequently cleaned).
- It is easy to inspect, by unscrewing it from the valve body for servicing the internal element in the event of obstruction with fibres or large impurities.

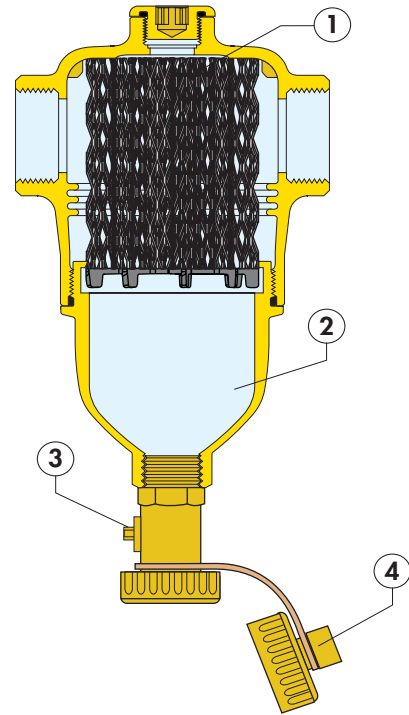

### Draining off with the system running.

The dirt separator collection chamber is fitted with a ball drain cock. Using the key provided it is possible to drain off impurities even with the system in operation.



### Top connection

The connection on the top of the dirt separator can be used to install an automatic air vent valve, Caleffi code 502243A.

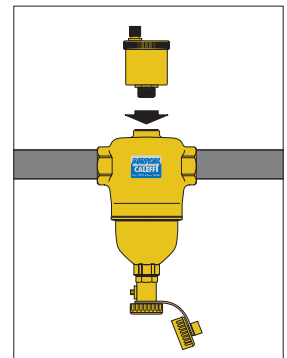

### Maintenance

To perform maintenance, simply use a 26 mm hexagon wrench (1) to unscrew the dirt collection chamber, to which the inner element is fixed in such a way that it can be removed for cleaning.

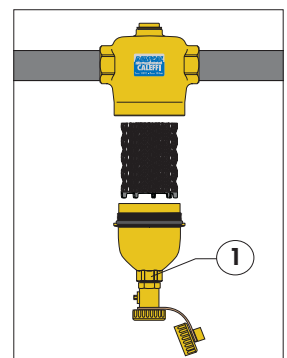

## Hydronic characteristics

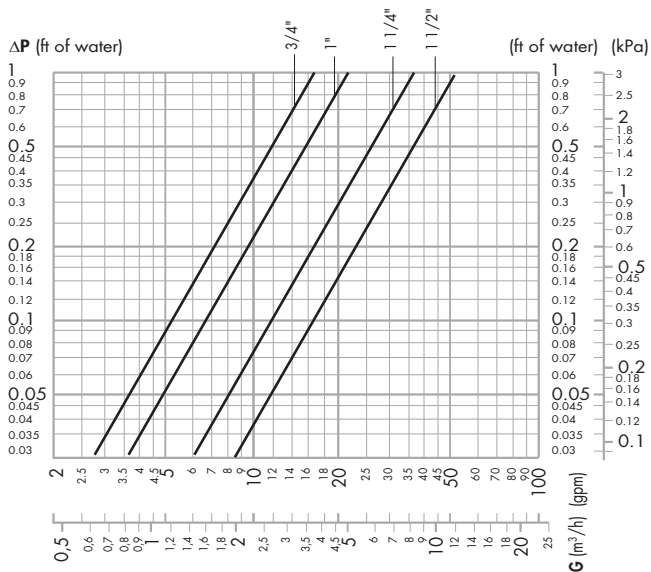

The maximum fluid velocity recommended at the unit connections is ~ 4.0 f/s. The following table shows the recommended flow rates to comply with this condition.

Size	3/4" NPT / 1" Swt	1" NPT / 1 1/4" Swt	1 1/4" NPT	1 1/2" NPT
Gpm	8	9.3	15.3	23.9
m <sup>3</sup> /h	1.8	2.1	3.5	5.4
Cv	19	22.1	36.4	56.8

## Separation efficiency

The capacity for separating the impurities in the medium circulating in the closed circuits of the systems basically depends on three parameters:

- 1) It increases as the size and mass of the particle increase. The larger and heavier particles drop before the lighter ones.
- 2) It increases as the speed decreases. If the speed decreases, there is a calm zone inside the dirt separator and the particles separate more easily.
- 3) It increases as the number of recirculations increases. The medium in the circuit, flowing through the dirt separator a number of times during operation, is subjected to a progressive action of separation, until the impurities are completely removed.

The Caleffi DIRTCAL dirt separator, thanks to the special design of its internal element, is able to completely separate the impurities in the circuit down to a minimum particle size of 5 µm.

The graph alongside, summarising the tests carried out in a specialised laboratory (TNO - Science and Industry), illustrates how it is able to quickly separate nearly all the impurities. After only 50 recirculations, approximately one day of operation, up to 100% is effectively removed from the circuit for particles of diameter greater than 100 µm and on average up to 80% taking account of the smallest particles. The continual passing of the medium during normal operation of the system gradually leads to complete dirt removal.

## Reduced head losses

A normal Y strainer performs its function via a metal mesh selected for the size of the largest particle. The medium therefore has a consequent initial loss of head that increases as the degree of clogging increases.

Whereas, the dirt separator carries out its action by the particles striking the internal element and subsequently dropping into the collection chamber. The consequent head losses are greatly reduced and are not affected by the amount of impurities collected.

## Particle separation capacity - Dirt separator efficiency

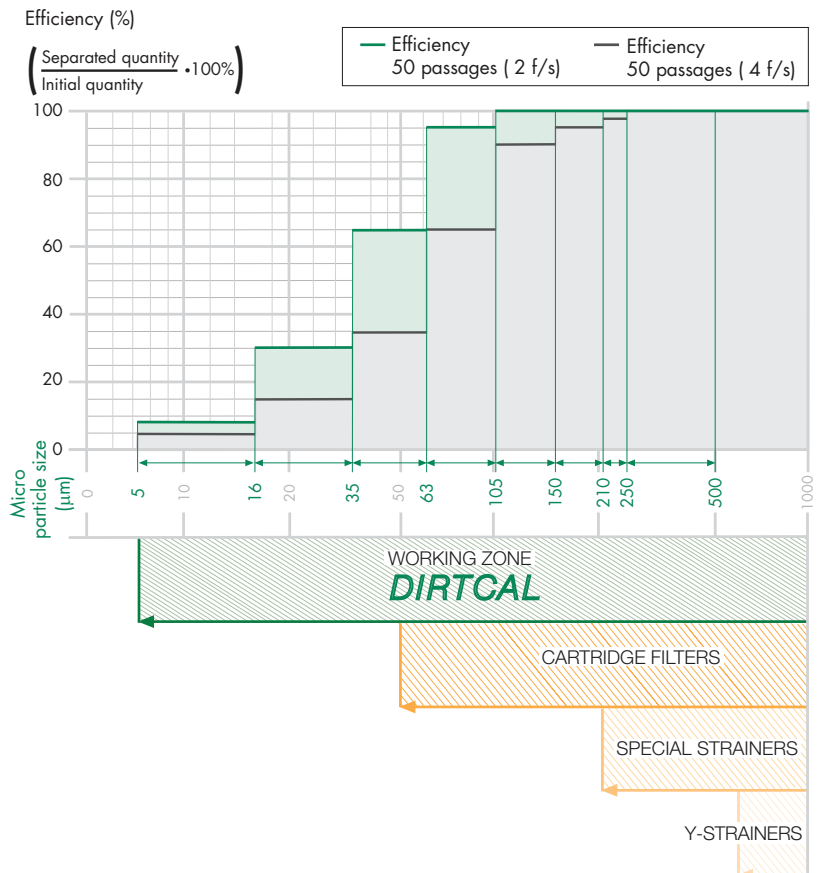

## Installation

The dirt separator must always be installed in a vertical position, preferably on the return circuit upstream of the boiler. This enables it to intercept impurities already present in the circuit, particularly when it is first started, before they reach the boiler.

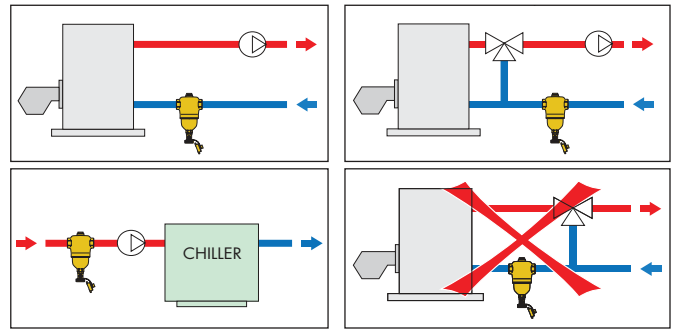
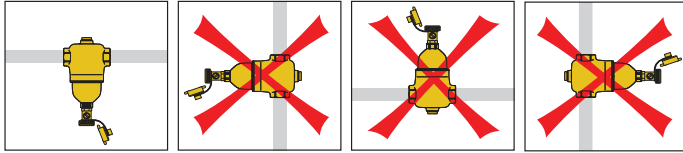

## Application diagram

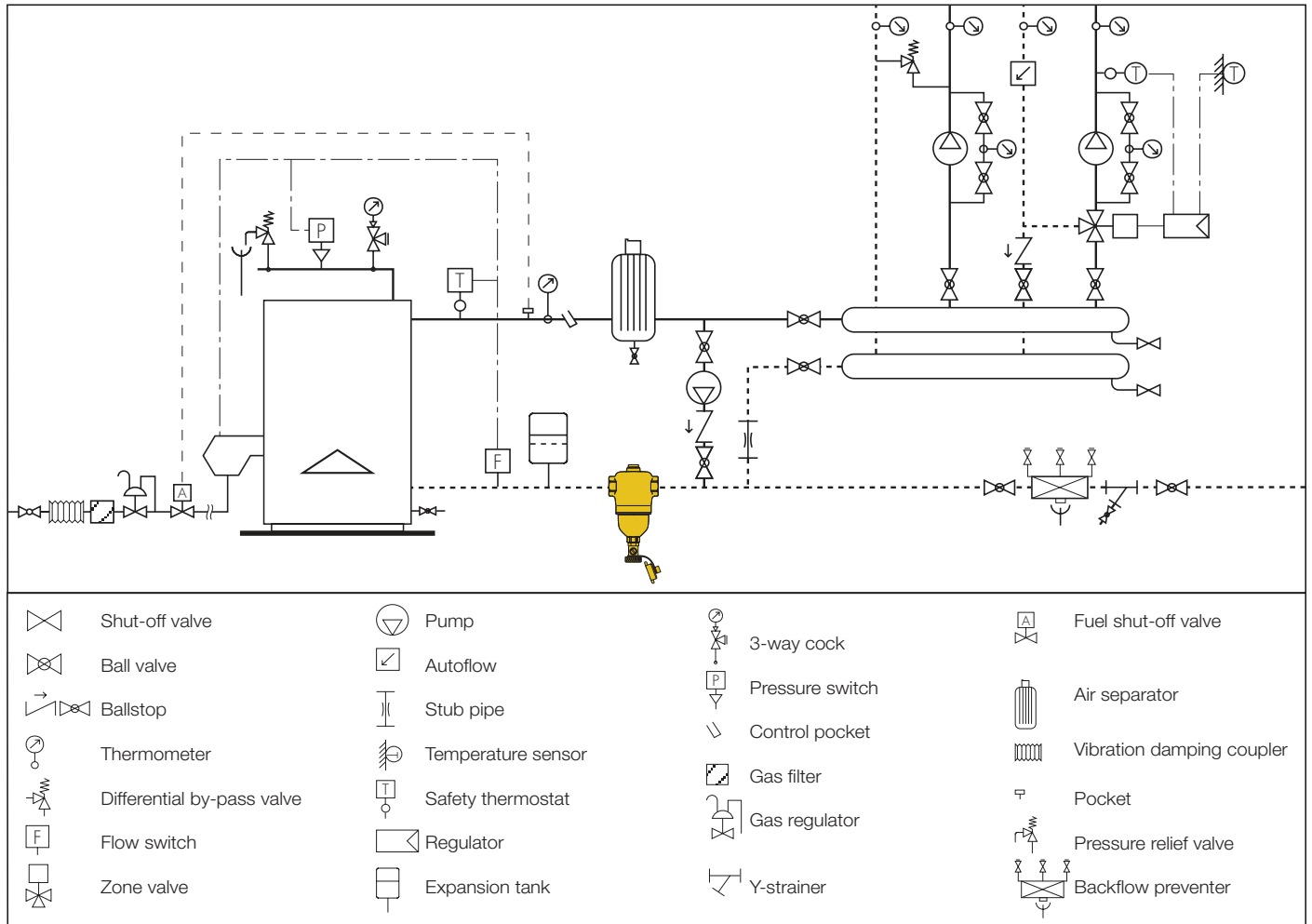

## SPECIFICATION SUMMARIES

### 5462 Series DIRTCAL

Dirt separator in brass. Threaded connections from 3/4" to 1-1/2" and sweat connections 1 & 1-1/4". Top connection 1/2" F (with plug). Drain valve with hose connection. Internal mesh element of PA66G30, removable for cleaning operations. Brass body. EPDM hydraulic seals. Glycol maximum 50%. Maximum working pressure 150 psi (10 bar). Temperature range 32 to 230°F (0-110°C). Particle separating capacity to 5µm.

We reserve the right to change our products and their relevant technical data contained in this publication at any time and without prior notice.



Caleffi North America, Inc.  
 9850 South 54th Street / Milwaukee, WI 53132  
 Tel: 414.421.1000 / Fax: 414.421.2878 / www.caleffi.us  
 © Copyright 2007 Caleffi North America, Inc.