

# The BIASI B-10 Boiler System



- Energy Star compliant
- Compact size
- Limited lifetime warranty



Quincy Hydronic Technology, Inc. • 1-800-501-7697 • E-mail: [info@qhtinc.com](mailto:info@qhtinc.com)

# BIASI...The Style of Warmth

The B-10 boiler system has been heating residential buildings throughout the world for years. It has proven its fuel efficiency and durability in countries where fuel can cost up to four times as much as in the U.S. The same fuel saving technology is now available here in North America. With the three pass boiler design and low water content, heat is quickly supplied for your heating zones and hot water needs. Combined with an electronic optimizing control, you can achieve a fuel savings of up to 40% over conventional single pass boilers. You will also have peace of mind since the B-10 boiler package complies with ASME and UL standards and is IBR rated. The B-10 boiler system is the cost-competitive heat and hot water system of choice.

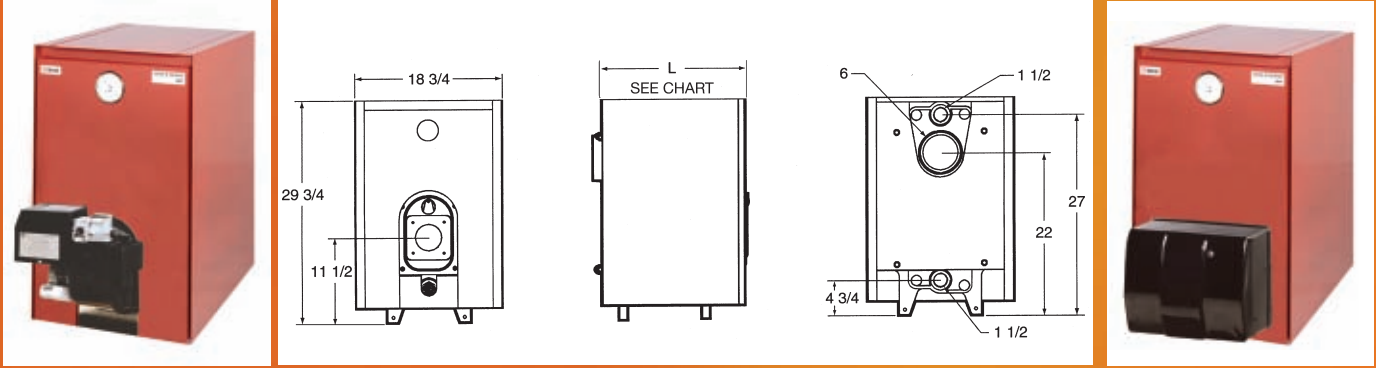

## The BIASI B-10 Residential Series

Boiler Model #	D.O.E. Heating Capacity	Gross Input Burner Capacity		Net I.B.R. Output (MBH)	AFUE Efficiency (%)	Water Content (Gals.)	Length (L) (Inches)	Weight (Lbs.)
		G.P.H.	MBH					
B-3	67	0.55	80	58	86.6	3.7	15.5	247
B-4	97	0.80	112	84	86.8	4.7	19.5	307
B-5	124	1.00	140	108	87.2	5.7	23.5	367
B-6	153	1.25	175	133	86.7	6.7	27.5	427
B-7	185	1.50	215	161	86.8	7.7	31.5	486
B-8	211	1.80	257	183	86.8	8.7	35.5	546
B-9	257	2.10	298	223	86.5	9.7	39.5	606

Maximum water working pressure: 58 PSI. (1) The burner input is based on oil with a heat value of 140,000 BTU/Gal.; (2) The net output ratings shown are based on piping and pick-up allowance of 1.15; (3) The efficiency ratings are based on a combustion condition of 12.5% CO<sub>2</sub>. Warranty: The BIASI B-10 boiler has a limited lifetime warranty. A copy is provided with each boiler or is available from your dealer. Built in accordance with the requirements of ASME boiler and pressure vessel code.

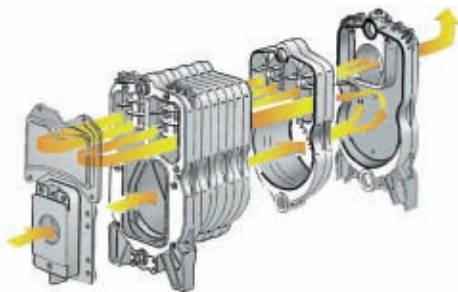

A 3-pass boiler design is the most efficient way to get the maximum amount of heat from the fuel, since it contains three times as much interior surface area (compared to a single-pass boiler) to extract heat from.

### Technical Advantages

- Gas or oil burner compatible
  - Easy access swing door
- No flue required; can be direct vented outdoors
- Low water content boiler heats up faster with less fuel
  - Efficient 3-pass heat exchanger boiler design
  - GG20 cast-iron construction for superior heat retention and durability
    - ASME, UL, and IBR listed
    - 58 psi cast-iron construction



Exclusively distributed by:



Quincy Hydronic Technology, Inc. • 1-800-501-7697 • E-mail: info@qhtinc.com