

Phase III[®]

Indirect Fired Water Heaters

TR Series

SMART Series



Technical Specifications Installation and Maintenance Guide

WARNING

- Before proceeding with installation and operation, read entire manual carefully. Failure to do so can cause injury or property damage.

IMPORTANT

- When receiving Phase III[®] equipment, any claims for damage or shortage in shipment must be filed immediately against the transportation company by the consignee.
- Warranty Registration Card must be filled out by the customer and mailed within thirty (30) days of installation in order to gain warranty coverage.
- Retain and affix this manual near the water heater for future reference
- Installation and service should only be performed by a qualified installer or service technician.
- Installations and service should be performed by a license plumber or gas fitter in the Commonwealth of Massachusetts.

Product & Safety Information	1
Pre-Installation	2-3
Installation - Piping	
- Temperature & Pressure (T&P) Relief Valve	4-5
- Drain Valve	5
- Automatic Air Vent	5
- Thermal Expansion	5
- Water Hammer	6
- Vacuum Breaker	6
- General Piping	6
- Domestic Piping	6-7
- Thermostatic Mixing Valve	7
- Recirculation Piping	7
- Multiple Water Heater Systems	7
- Boiler Piping	7
Installation -Piping Drawings	8-14
Installation - Wiring	
- Wiring Requirements	15
- Circulators	15
- Zone Valves	15
- Snap-Set Connection	15
Installation - Wiring Drawings	16-19
Water Heater Start-Up	
- Filling the Inner (Domestic Water) Tank	20
- Filling the Outer (Boiler Water) Tank	20
- General Notes	21
- Adjusting the Water Heater Thermostat	22
Water Heater Maintenance	
- Maintenance Schedule	23
- Filling Water Heater	23
- Draining Water Heater	23-24
- Draining Inner (Domestic Water) Tank	24
- Draining Outer (Boiler Water) Tank	24

Page

Water Heater Specifications

- TR Series25
- SMART Series26

Performance27

Replacement Parts List

- TR Series28
- SMART Series28

Sample Specifications29

Warranty (See Warranty Certificate enclosed in your water heater package)

Following terms are used to bring attention to the presence of various risk levels, or to important information concerning product life.

DANGER

Indicates presence of a hazard which will cause severe personal injury, death or substantial property damage if ignored.

WARNING

Indicates the presence of a hazard which can cause severe personal injury, death or substantial property damage if ignored.

CAUTION

Indicates the presence of a hazard which will or can cause minor personal injury or damage if ignored.

NOTICE

Indicates special instructions on installation, operation, or maintenance which are important but not related to personal injury hazards.

DANGER**Hot Water Can Scald!**

- Water temperatures over 125°F can cause severe burns instantly or death from scalding.
- Children, disabled and elderly are at highest risk of being scalded.
- Never leave them unattended in or near shower, bathtub or sink.
- Never allow small children to use a hot water faucet or draw their own bath.
- If anyone using hot water in the building fits this description or if local codes or state laws require specific water temperatures at hot water faucet, it is recommended:
 - to install a thermostatic mixing valve at this appliance or at each water faucet.
or
 - to set the thermostat knob for the lowest temperature which satisfies your hot water needs.
- Water drained from the system drain valves may be extremely hot. To avoid injury:
 - Make sure all connections are tight.
 - Direct water flow away from any person.

CAUTION

Protection must be taken against excessive temperature and pressure!

- Installation of a Temperature & Pressure (T&P) relief valve is required.

CAUTION

To prevent damage to the inner tank, the Installer must:

- Always fill inner tank prior to outer tank and always drain outer tank prior to inner tank.
- Relieve primary system pressure below 15 psig prior to draining inner tank.

Codes Compliance

Water heater installation must conform with the instructions in this manual and where applicable:

- local, state, provincial, and national codes, laws, regulations and ordinances.
- in Canada - CAN / CGA B149.1 or B149.2 Installation Code.

PhaseIII® water heaters are exempt from ASME Section VIII, Division 1 Code construction per Interpretation VIII-86-136. Check with local codes for applicability.

Where recommendations in this manual differ from local, or national codes, the local or national codes take precedence.

Codes Restrictions

Single wall heat exchanger in the water heater complies with National Standard Plumbing Code, provided that:

- boiler water (including additives) is practically non-toxic, having toxicity rating or class of 1, as listed in Clinical Toxicology of Commercial Products, and
- boiler water pressure is limited to maximum 30 psig by approved relief valve.

Single wall heat exchangers are permitted under the Uniform Plumbing code - Paragraph L3.2. and L3.3 if they satisfy all of the following requirements.

1. The heat transfer medium is potable water or contains only substances which are recognized as safe by the U.S. Food and Drug Administration.
2. The pressure of the heat transfer medium is maintained less than the normal minimum operating pressure of the potable water system
Exception: Steam complying with section #1 above.
3. The equipment is permanently labeled to indicate that only additives recognized as

safe by the FDA shall be used in the heat transfer medium.

Other heat exchanger designs may be permitted where approved by the Administrative Authority.

Operating Restrictions

- Maximum domestic hot water temperature is 190°F. Used for special applications.
- Maximum boiler water temperature is 210°F.
- Maximum working pressure for inner (domestic water) tank is 150 psig.
- Maximum working pressure for outer (boiler water) tank is 45 psig.
- pH and chloride limits for water heaters are:
 - chloride, less than 80 mg/l
 - pH value min. 6 - max. 8

NOTICE

Any water conditioning system must be installed and maintained in accordance with manufacturer's specifications.

Locating Water Heater

- This water heater is not intended for outdoor installations.
- Keep distance between boiler and water heater to a minimum to:
 - reduce piping heat loss
 - provide minimal friction loss
- Locate water heater so that any leakage from the tank or water connections will not cause damage to the area adjoining the water heater or to lower floors in the structure.
 - When such a location is unavoidable, a suitable drain pan with adequate drainage, should be placed under the water heater.
- The PhaseIII® TR Series and SMART Series Water Heaters are designed for vertical installation only.

Recommended Clearances

- Water heater should be installed to allow adequate clearance for servicing
- Zero clearance is permissible to either side of the TR and SMART Series water heater, but information labels may be hidden.
- Recommended top or vertical clearance is 12” minimum.
- Refer to boiler manual for boiler clearances

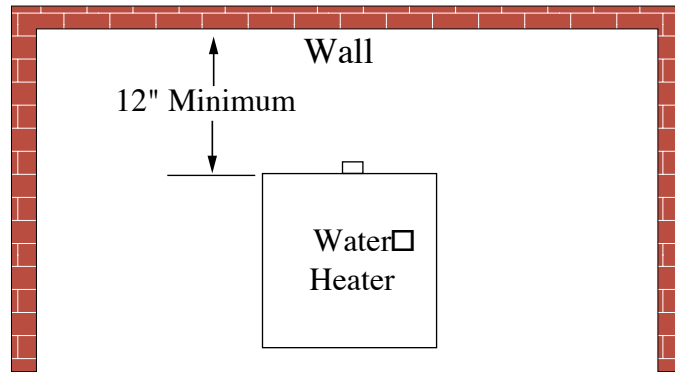

TR Tank- Top View

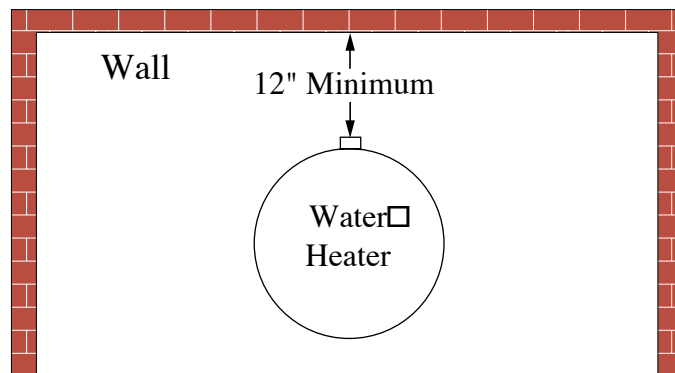

SMART Tank- Top View

Temperature & Pressure (T&P) Relief Valve

CAUTION

To reduce risk of excessive pressures and temperatures in the water heater, install temperature and pressure protective equipment required by local codes, but no less than a combination temperature and pressure relief valve certified by a nationally recognized testing laboratory that maintains periodic inspection of production of listed equipment or materials, as meeting the requirements for Relief Valves and Automatic Gas Shutoff Devices for Hot Water Supply Systems, ANSI Z21.22. This valve must be marked with a maximum working pressure of the water heater.

- Every Phase III® water heater must be protected with a T&P relief valve.
- Determine T&P relief valve size by the following specifications, unless they conflict with local codes:
 - TR 20/30/36/45 - SMART 20/30/40/50: 3/4"NPT with an AGA Rating of 100,000 BTU/hr. (Watts 100XL-8 or equivalent).
 - TR 60/80/100/120 - SMART 60/80/100: 3/4"NPT with an AGA Rating of 200,000 BTU/hr. (Watts 40XL-8 or equivalent).

NOTICE

For proper operation of the T&P and to prevent the T&P from activating due to boiler water temperature, use a T&P relief valve with extended element. Recommended, an 8" minimum length.

NOTICE

Phase III® commercial water heaters will absorb less than 200,000 BTU/hr when domestic water outlet temperature is 210°F and boiler water supply temperature is 240°F. Listed outputs are based on ASME Section VIII Interpretation VIII-1-86-136. Check with local codes for applicability.

Standard Installation

- Install T&P relief valve in the **Auxiliary** connection located behind the air vent on the top of the water heater (Figure 1 page 8).
- or
- Install the T&P relief valve in the run (straight through leg) of a tee located at the domestic hot water outlet when using the **Auxiliary** connection for a recirculation return (Figure 2 page 9).

Commonwealth of Massachusetts Installation

Follow this procedure for jurisdictions requiring a vacuum breaker to be installed on the domestic cold water inlet.

- Install the T&P in the run (straight through leg) of a tee located at the domestic hot water outlet. Use a long element T&P relief valve (Figure 3 page 10).

T&P Relief Valve Discharge Piping

T&P relief valve discharge piping must be:

- made of material serviceable for temperatures of 250°F or greater.
- directed so that hot water flows away from all persons.
- directed to a suitable place for disposal.
- installed so as to allow complete draining of the T&P relief valve and discharge line.

T&P relief valve discharge piping **must not** be:

- excessively long. Using more than 2 elbows or 15 feet of piping can reduce discharge capacity.
- directly connected to a drain. Terminate discharge piping within 6" from drain. Refer to local codes.
- plugged, reduced or restricted.
- subject to freezing.

WARNING

Do not install any valve between T&P relief valve and tank connection or on T&P relief valve discharge piping. Do not plug T&P relief valve or discharge piping. Improper placement and piping of T&P relief valve can cause severe personal injury, death or substantial property damage.

Drain Valve

Drain valve and fittings are supplied by others.

Standard Installation

- Install a tee connection at the domestic cold water inlet (Figures 1 and 2 pages 8 and 9).
- Pipe the drain piping with drain valve from the tee connection to:
 - a suitable place for disposal
 - or
 - terminate within 12" of the floor

Commonwealth of Massachusetts Installation

- Insert an open-end dip tube into the Auxiliary connection on top of water heater.
- Install a 3/4" NPT elbow to the Auxiliary connection (Figure 3).
- Pipe the drain piping with drain valve from the elbow connection to:
 - a suitable place for disposal
 - or
 - terminate within 12" of the floor

Automatic Air Vent

1. Remove plastic shipping cap from 1/2" NPT pipe fitting on top center of water heater.
2. Install 1/2" x 1/8" reducer bushing provided with water heater, using suitable pipe dope or tape.
3. Install automatic air vent provided with water heater, using suitable pipe dope or tape.
4. Unscrew vent cap on air vent one full turn. Leave cap unscrewed one turn for normal venting.

Thermal Expansion

If a backflow preventer, check valve or pressure reducing valve is piped on cold water supply piping of water heater, install an expansion tank on cold water supply line to prevent normal thermal expansion from repeatedly forcing open T&P relief valve.

CAUTION

T&P relief valve is not intended for constant duty, such as relief of pressure due to repeated normal system expansion. Correct this condition by installing a properly sized expansion tank in domestic water system. Refer to expansion tank manufacturer's installation instructions for proper sizing.

Water Hammer

Dishwashers, clothes washers and fast-closing positive shut-off valves incorporated in the system all contribute to creating water shock. Install a water hammer arrester to prevent damage to pipes and appliances. See device manufacturer's instructions for application and installation.

NOTICE

Water hammering within the domestic piping system can cause premature failure of the inner tank of the water heater. This type of failure is *NOT* covered under warranty.

Vacuum Breaker

Installing a vacuum breaker on the domestic cold water outlet will prevent damage to the inner tank if a negative pressure is developed in the domestic supply line. See manufacturer's instructions for application and installation of the vacuum breaker.

General Piping

- For domestic water piping diagrams, see page 8 thru 10.
- See pages 11 through 14 for:
 - Boiler water piping
 - Multiple water heater domestic and boiler piping.
- See Chart 1 for domestic and boiler piping connections.
- All plumbing must meet or exceed all local, state and national plumbing codes.
- Use pipe dope or tape suitable for potable water systems.
- Use isolation valves to isolate system components.

Domestic Piping

- Union on domestic hot water outlet should be piped at a higher elevation than domestic water drain valve. This will make draining the water heater easier.
- Install unions for easy removal of water heater. Use dielectric unions or couplings to protect

Chart 1

Water Heater Model	Connections - NPT			Recirculation Dip Tube		Draining Dip Tube		Recommended Minimum Boiler Piping Diameter (inches)
	Domestic Water Inlet/Outlet	Boiler Water Supply/Return	Auxiliary Connection	Length inches	Diameter inches	Length inches	Diameter inches	
TR-20	3/4	1	3/4	34	3/4	34	3/4	1
TR-30	3/4	1	3/4	43	3/4	43	3/4	1
TR-36	3/4	1	3/4	52	3/4	52	3/4	1
TR-45	1	1 1/4	3/4	25	3/4	47	3/4	1 1/4
TR-60	1	1 1/4	1	25	1	54	1	1 1/4
TR-80	1 1/2	2	1 1/2	25	1 1/2	48	1 1/2	2
TR-100	1 1/2	2	1 1/2	32	1 1/2	61	1 1/2	2
TR-120	1 1/2	2	1 1/2	32	1 1/2	61	1 1/2	2
SMART 20	3/4	1	3/4	23.5	3/4	23.5	3/4	1
SMART 30	3/4	1	3/4	34	3/4	34	3/4	1
SMART 40	3/4	1	3/4	43	3/4	43	3/4	1
SMART 50	3/4	1 1/4	3/4	25	3/4	52	3/4	1 1/4
SMART 60	3/4	1 1/4	3/4	34	3/4	62	3/4	1 1/4
SMART 80	1 1/2	1 1/2	1 1/2	25	1 1/2	48	1 1/2	1 1/2
SMART 100	1 1/2	1 1/2	1 1/2	32	1 1/2	61	1 1/2	1 1/2

hot and cold water fittings from corrosion when connecting dissimilar materials such as copper and galvanized iron pipe.

- If copper pipe is used for domestic water connections, first solder pipe to a threaded adapter and then screw adapter into cold water inlet on top of water heater. Inlet contains an internal plastic dip tube which can be damaged by heat from soldering.

NOTICE

Do not apply heat to the cold water inlet when making sweat connections to water heater. Sweat tubing to adapter before fitting adapter to cold water inlet of heater. It is imperative that no heat be applied to the cold water inlet, as it contains a non metallic dip tube.

- When the water supply pressure is higher than 70 psig, it is recommended to install a pressure reducing valve on cold water supply line to prevent water loss through T&P relief valve.
- If water heater will replace tankless coil in boiler, disconnect piping to coil. Allow water to drain from coil. Do not plug tankless coil.

DANGER

Plugging tankless coil inlet and outlet will result in severe personal injury, death, or substantial property damage.

Thermostatic Mixing Valve

- Optional mixing valve may be installed on the domestic hot water outlet.
- Mixing valve should comply with ASSE 1017

Recirculation Piping

- T&P relief valve must be installed in run (straight through leg) of tee located at domestic hot water outlet of water heater.
- Recirculation dip tube must be installed in auxiliary connection. See Chart 1 page 6 for sizing.

- A stainless steel or bronze circulator is recommended
- Install automatic mixing valve either at the hot water outlet of water heater or each hot water faucet.

Multiple Water Heater Systems - Recirculation Piping

- Parallel Pipe recirculation Systems - Manifold recirculation return to all water heaters.
- Series Piped Systems - Piped return to the leading (cold water inlet) water heater.
- Install automatic mixing valve either at the hot water outlet of water heater or each hot water faucet.

DANGER

Failure to install automatic mixing valve where recommended will result in severe personal injury or death.

Boiler Piping

- If plastic pipe is used for boiler water piping, it must have a maximum oxygen diffusion rate of 0.1 mg/liter-day for boiler and water heater protection.
- Boiler water (including additives) must be practically non-toxic, having toxicity rating or class of 1, as listed in Clinical Toxicology of Commercial Products.

If antifreeze is used in boiler system, local codes may require a backflow preventer on cold water supply line. Use antifreeze specifically intended for hydronic heating systems. Inhibited propylene glycol is recommended at a maximum 50/50 mixture.

DANGER

Do not use automotive, ethylene glycol or petroleum-based antifreeze. Do not use any undiluted antifreeze. This can cause severe personal injury, death or substantial property damage.

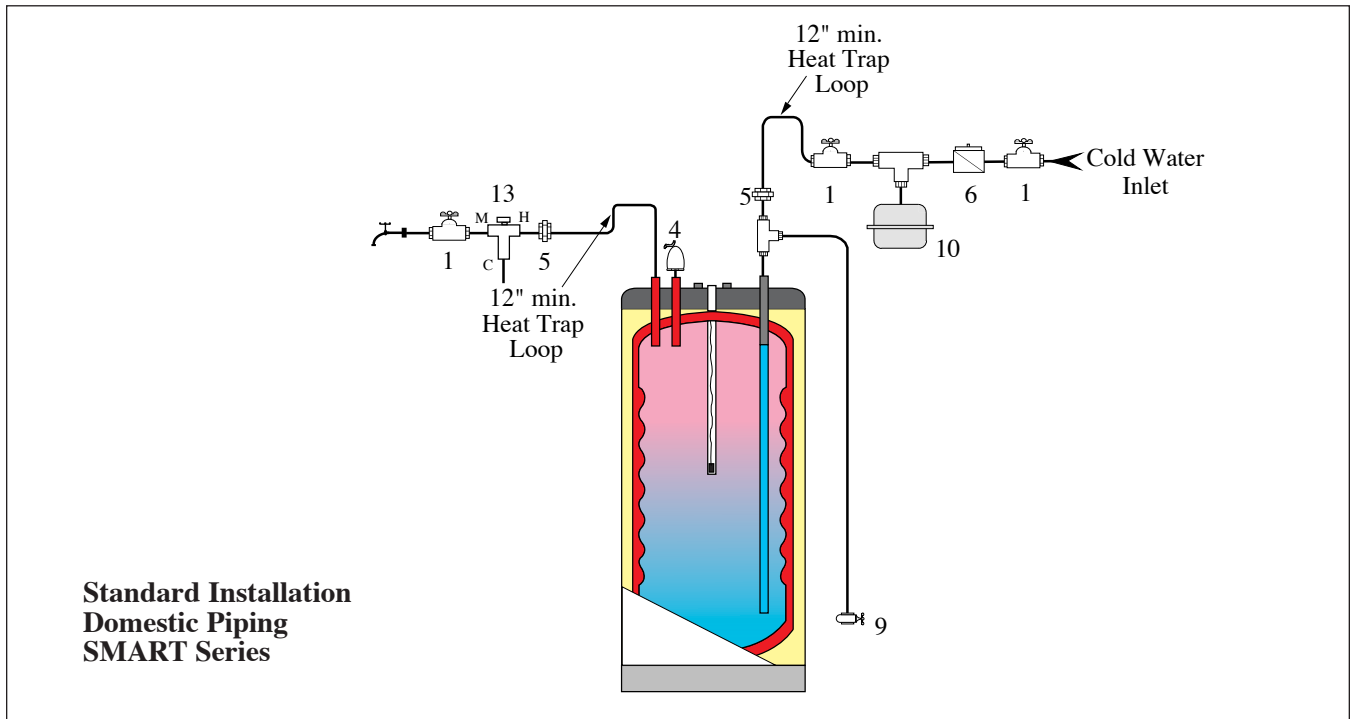
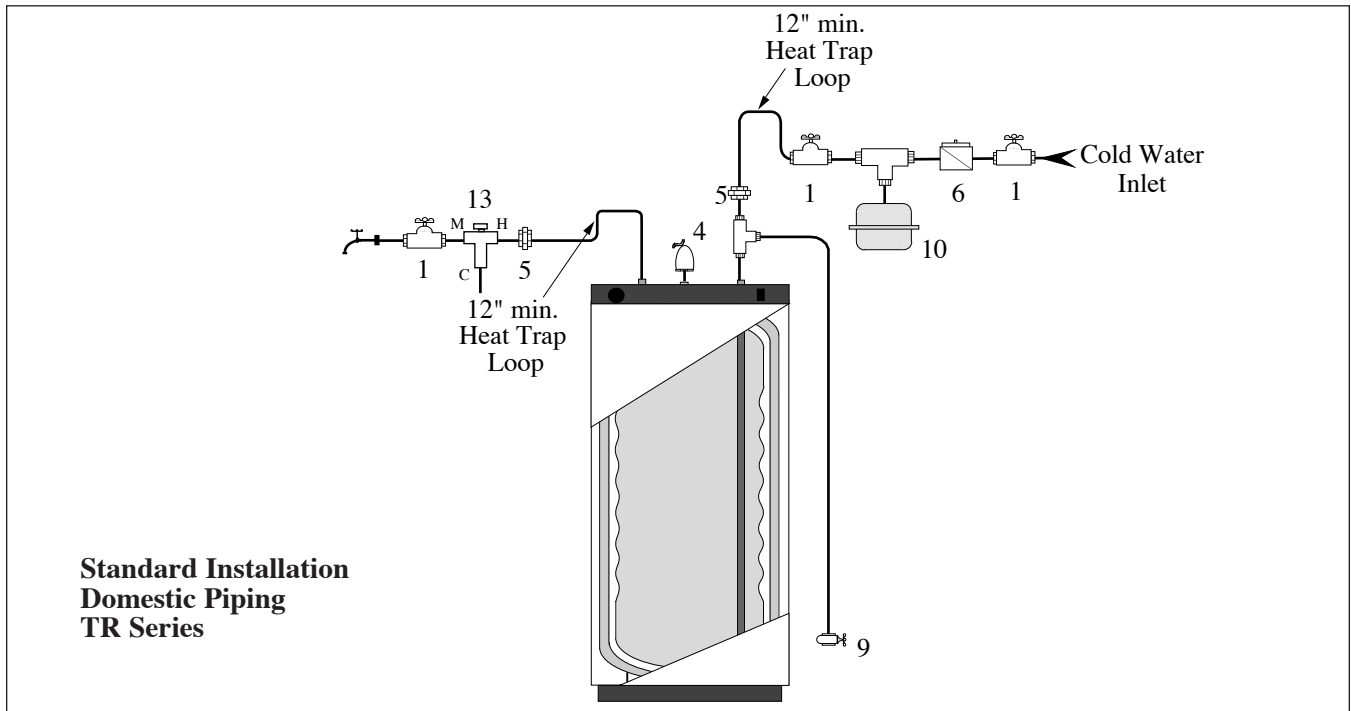

Figure 1

- | | |
|---|--|
| 1. Shut-off valve | 9. Drain valve |
| 4. T&P relief valve | 10. Thermal expansion tank (potable) |
| 5. Unions | 13. Thermostatic mixing valve (optional) |
| 6. Backflow preventer or pressure reducing valve(*) | (*) Optional devices may be required by local codes. |

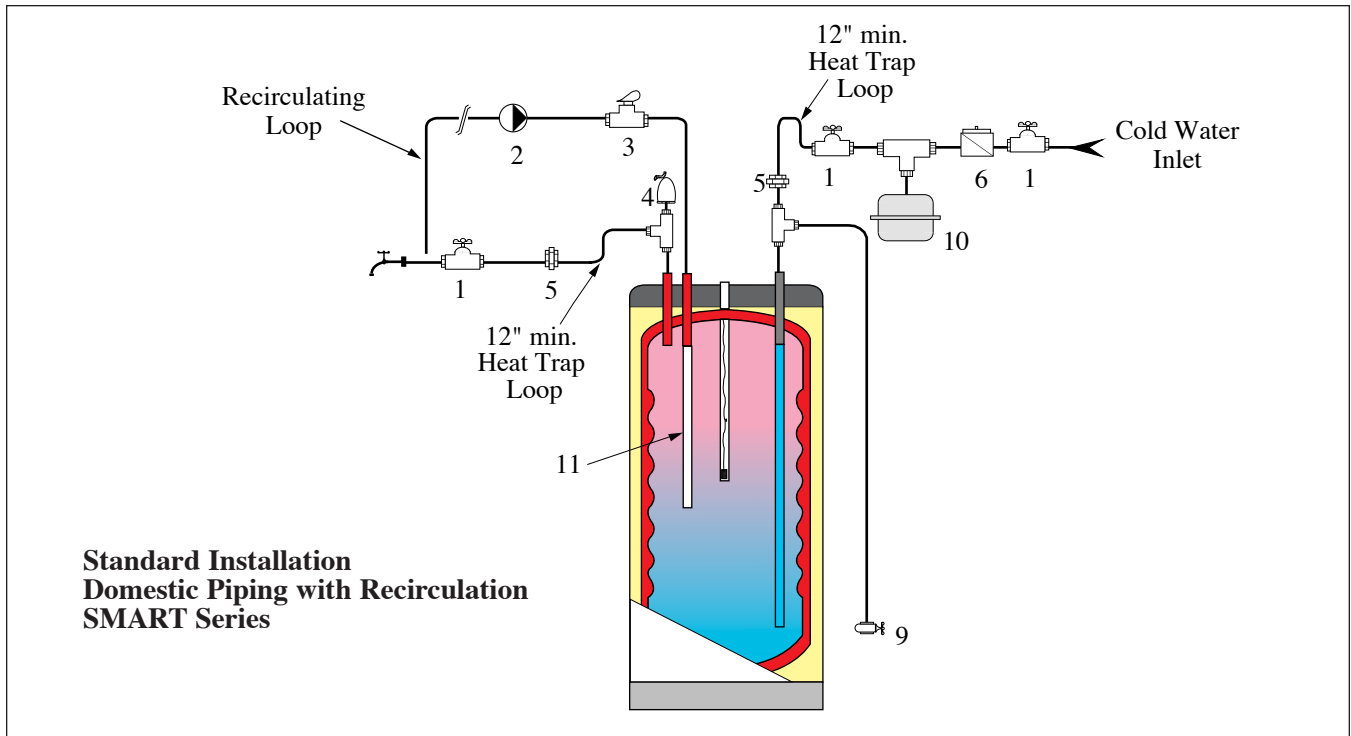
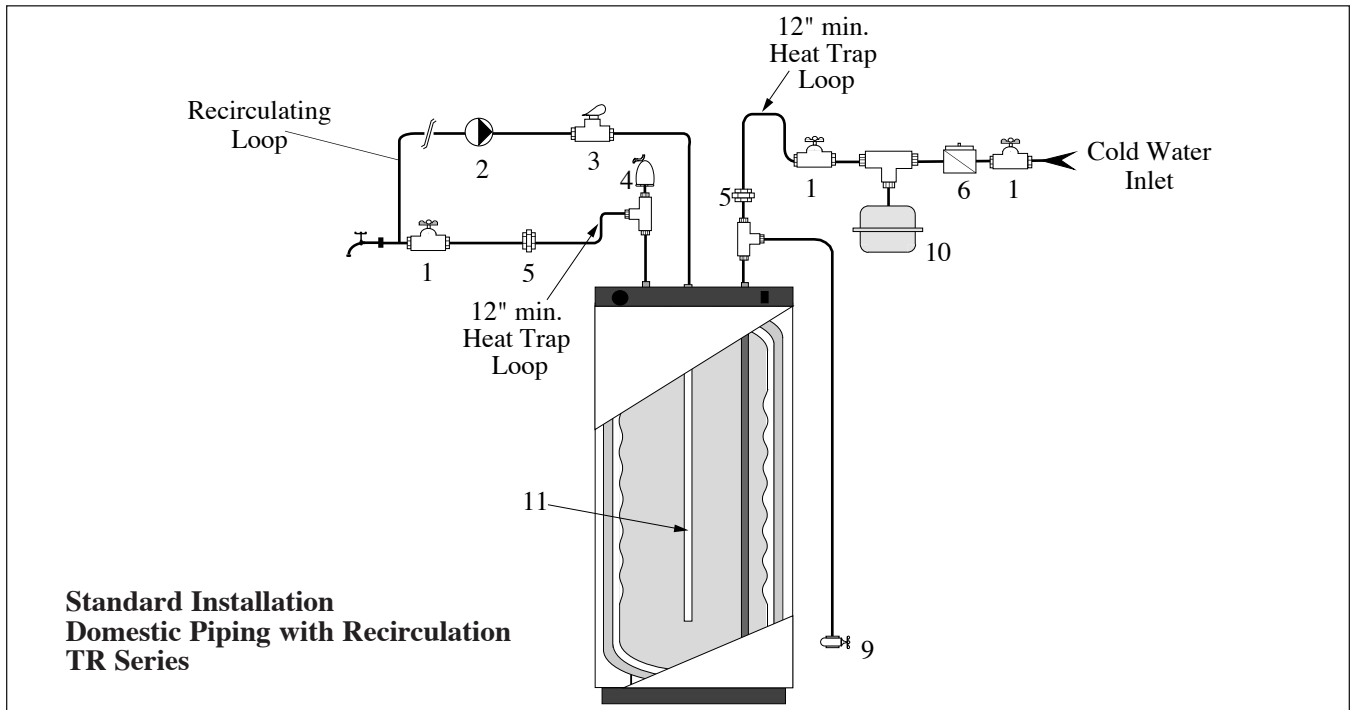

Figure 2

- | | |
|--|---|
| <ul style="list-style-type: none"> 1. Shut-off valves 2. Recirculation circulator 3. Flow check valve 4. T&P relief valve 5. Unions | <ul style="list-style-type: none"> 6. Backflow preventer or pressure reducing valve(*) 9. Drain valve 10. Thermal expansion tank (potable) 11. Dip Tube - Recirculation per Chart 1 (*) Optional devices may be required by local codes. |
|--|---|

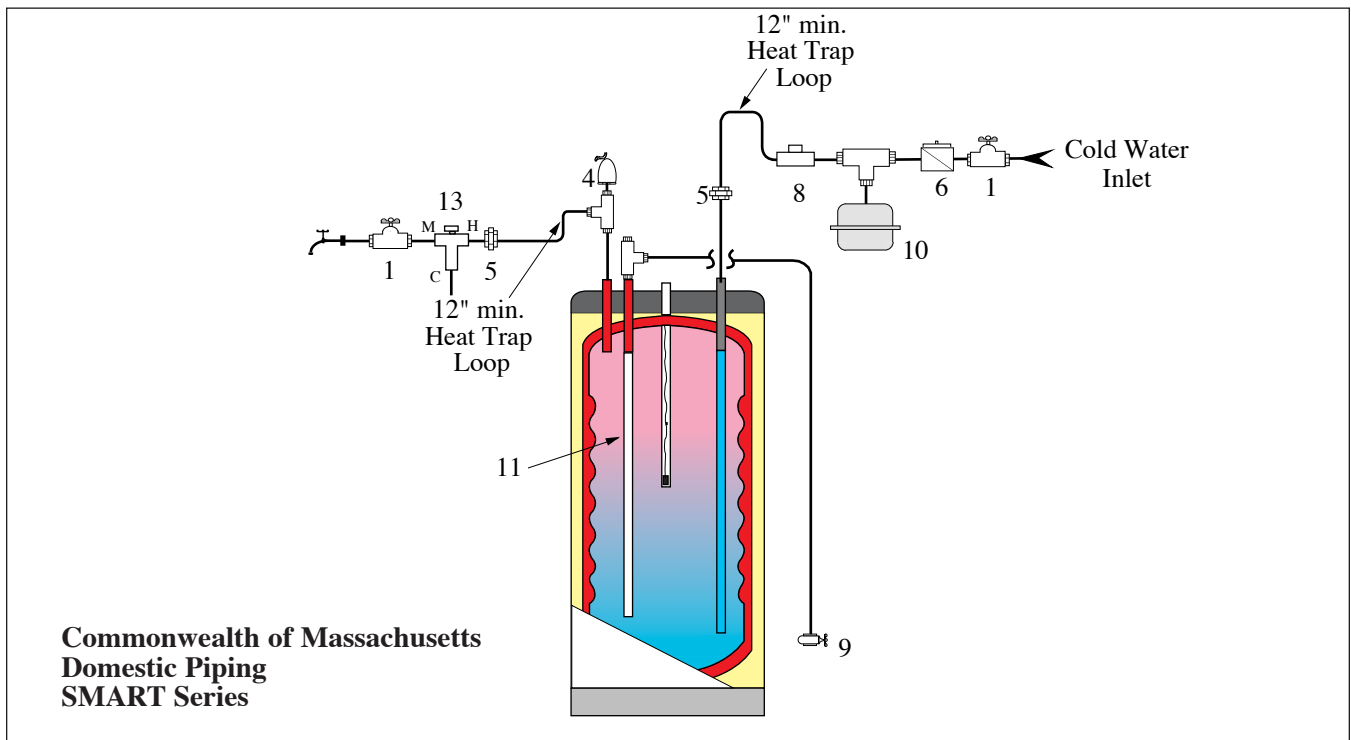
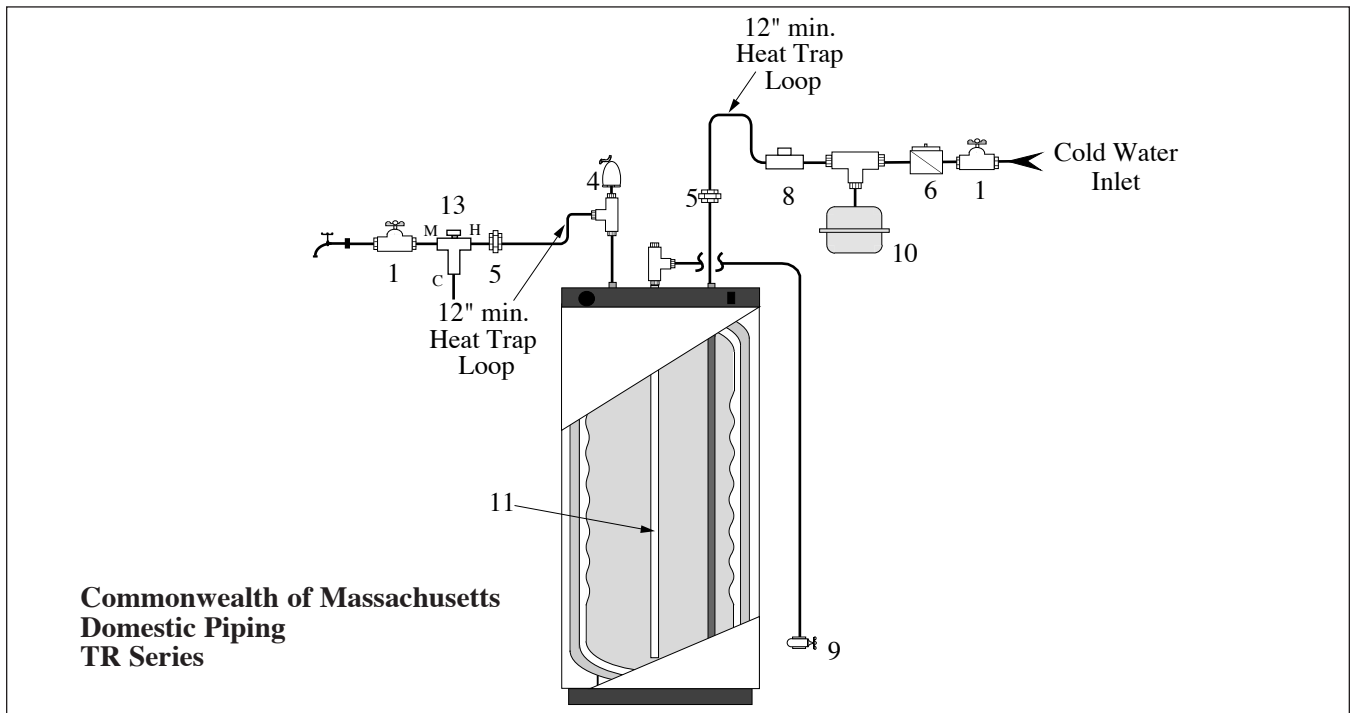
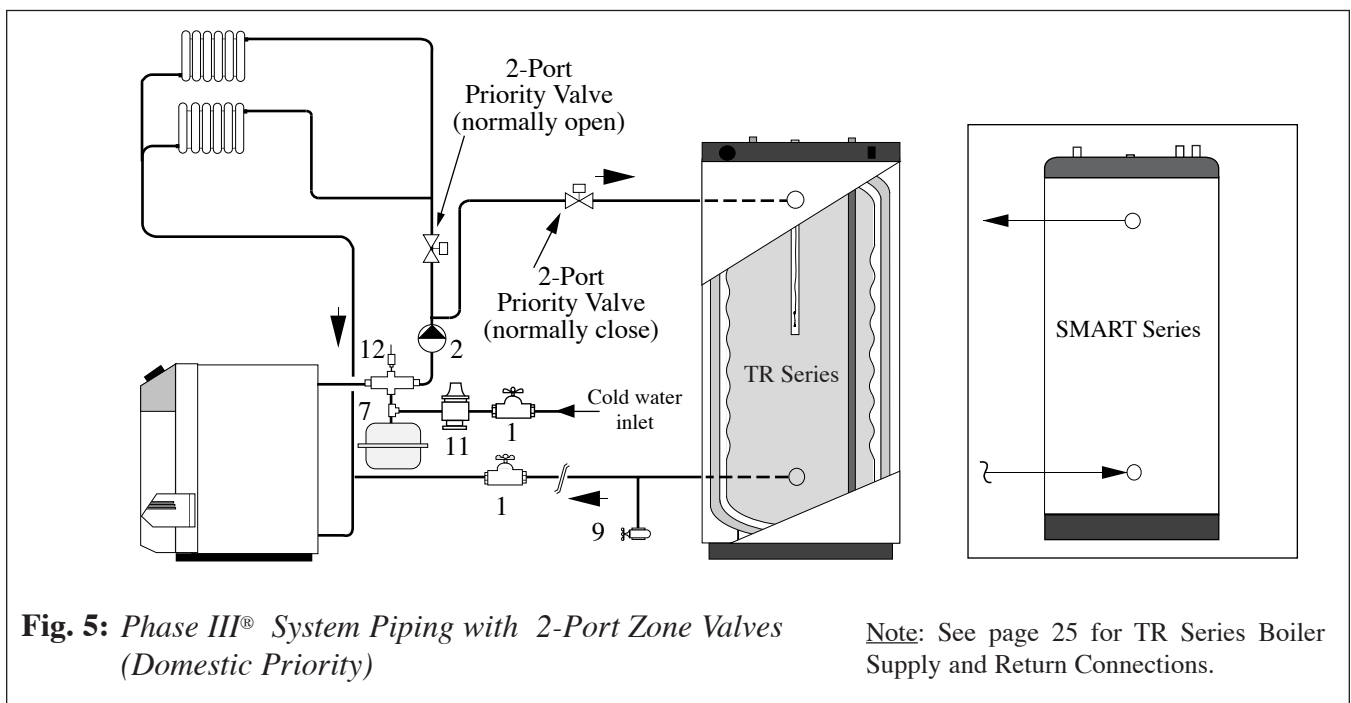
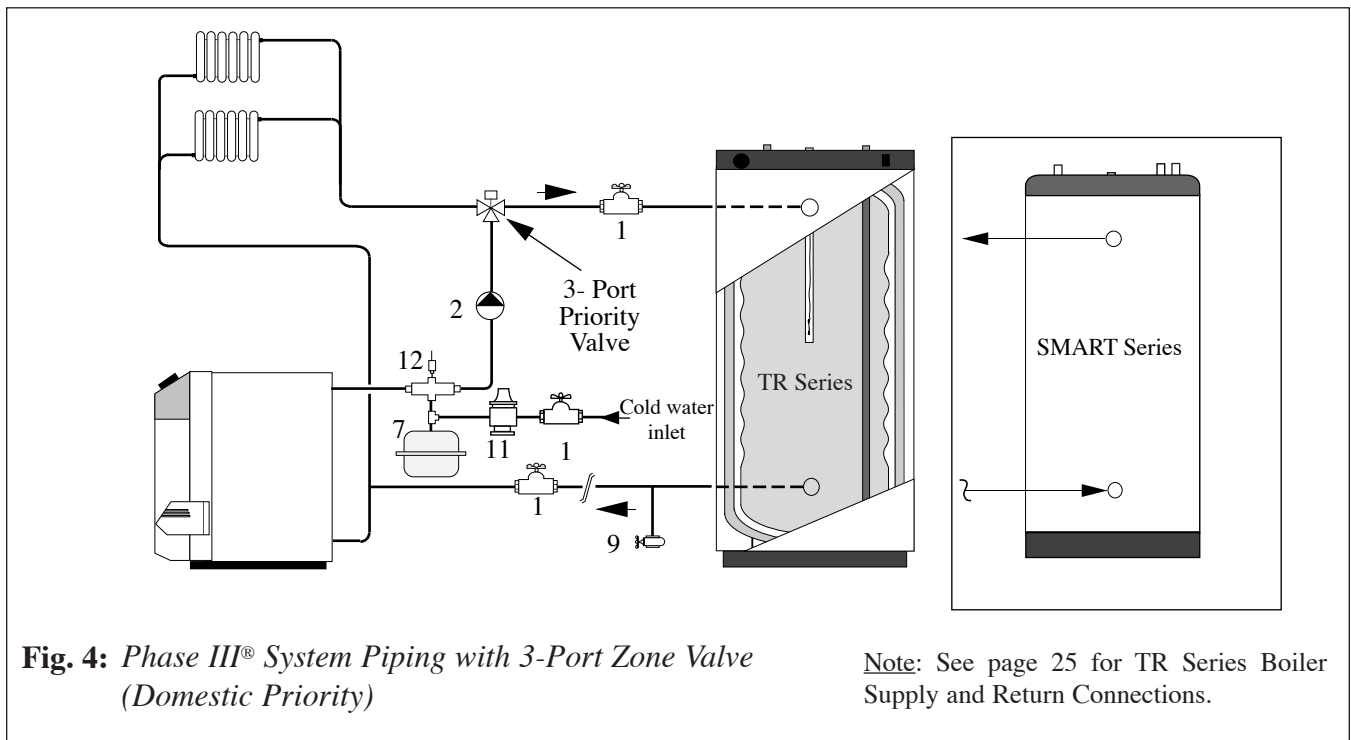

Figure 3

- | | |
|--|--------------------------------------|
| 1. Shut-off valves | 9. Drain valve |
| 4. T&P relief valve | 10. Thermal expansion tank (potable) |
| 5. Unions | 11. Dip tube - Draining per Chart 1 |
| 6. Backflow preventer or pressure reducing valve | 13. Mixing valve (optional) |
| 8. Vacuum breaker | |



- 1. Shut-off valves
- 2. Circulator
- 7. Expansion tank

- 9. Drain valve
- 11. Feed valve
- 12. Air separator

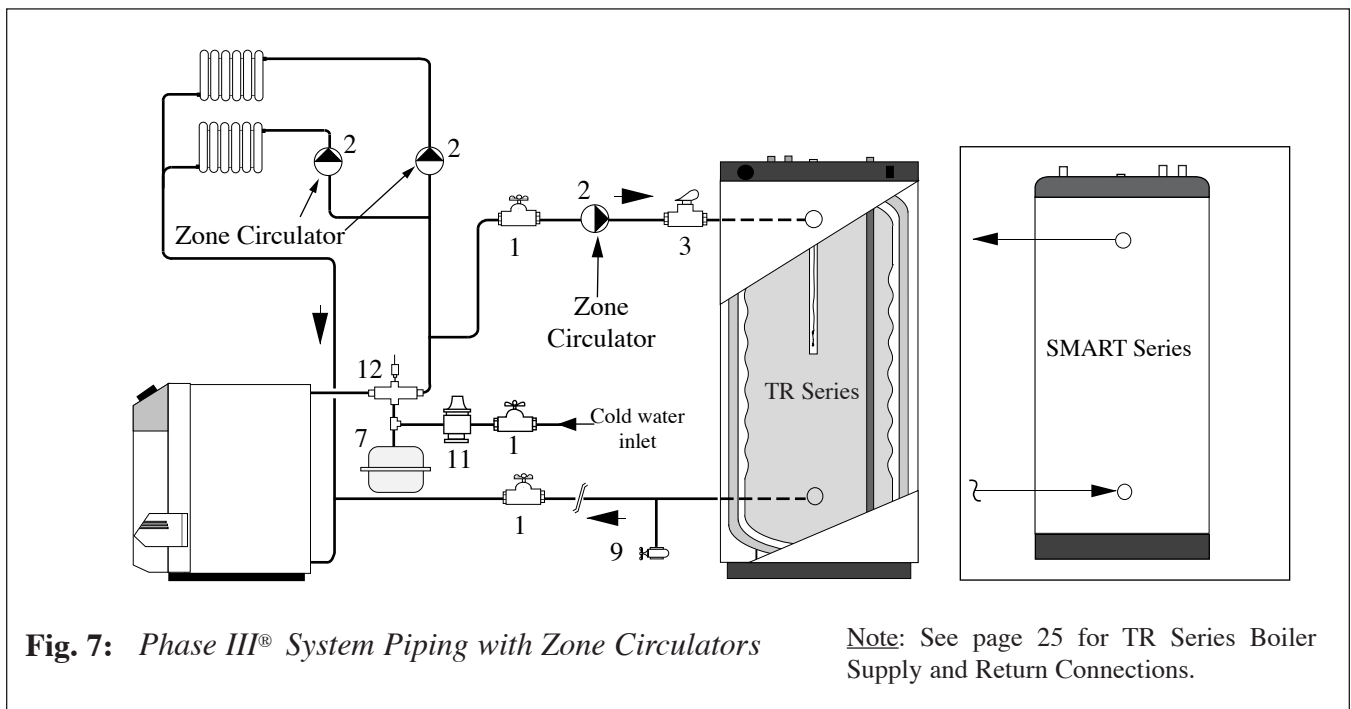
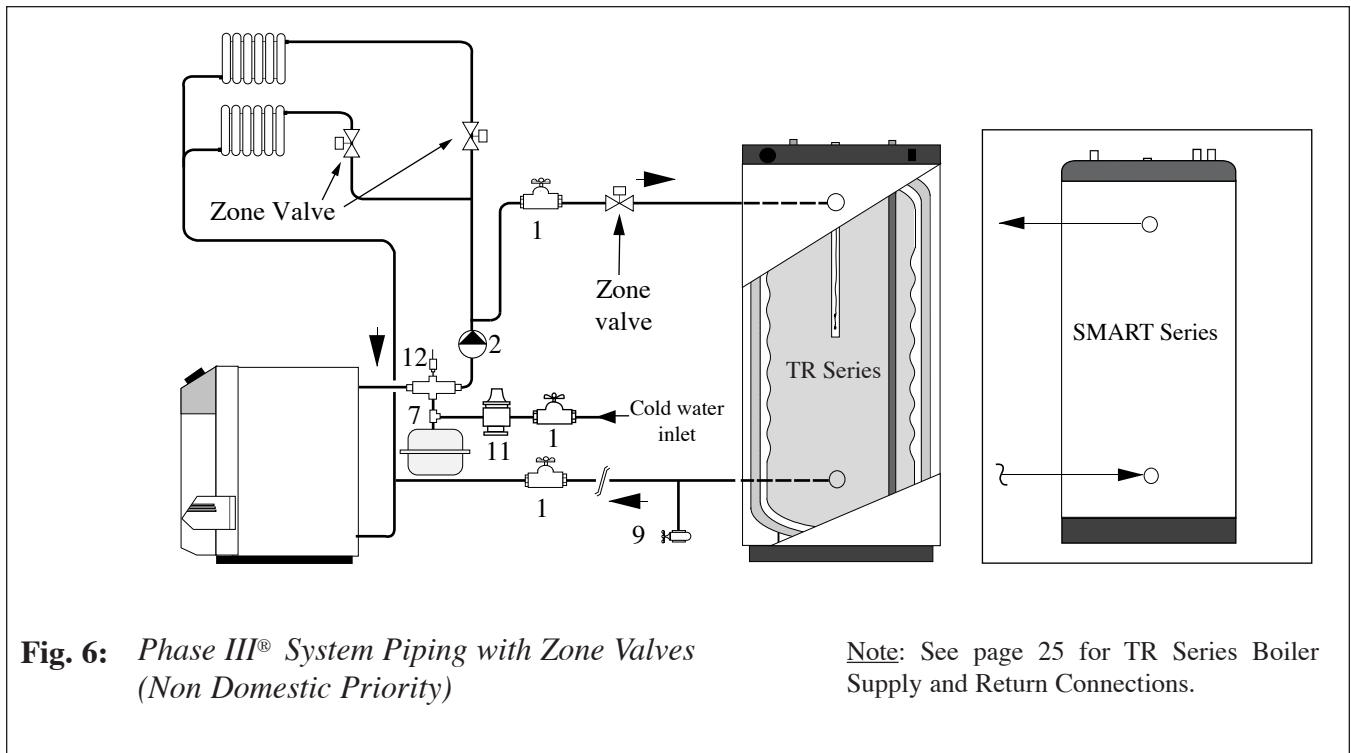

- | | |
|---------------------|-------------------|
| 1. Shut-off valves | 9. Drain valve |
| 2. Circulator | 11. Feed valve |
| 3. Flow check valve | 12. Air separator |
| 7. Expansion tank | |

Fig. 8: Multiple TR Series Water Heater System
Domestic Piping - Parallel

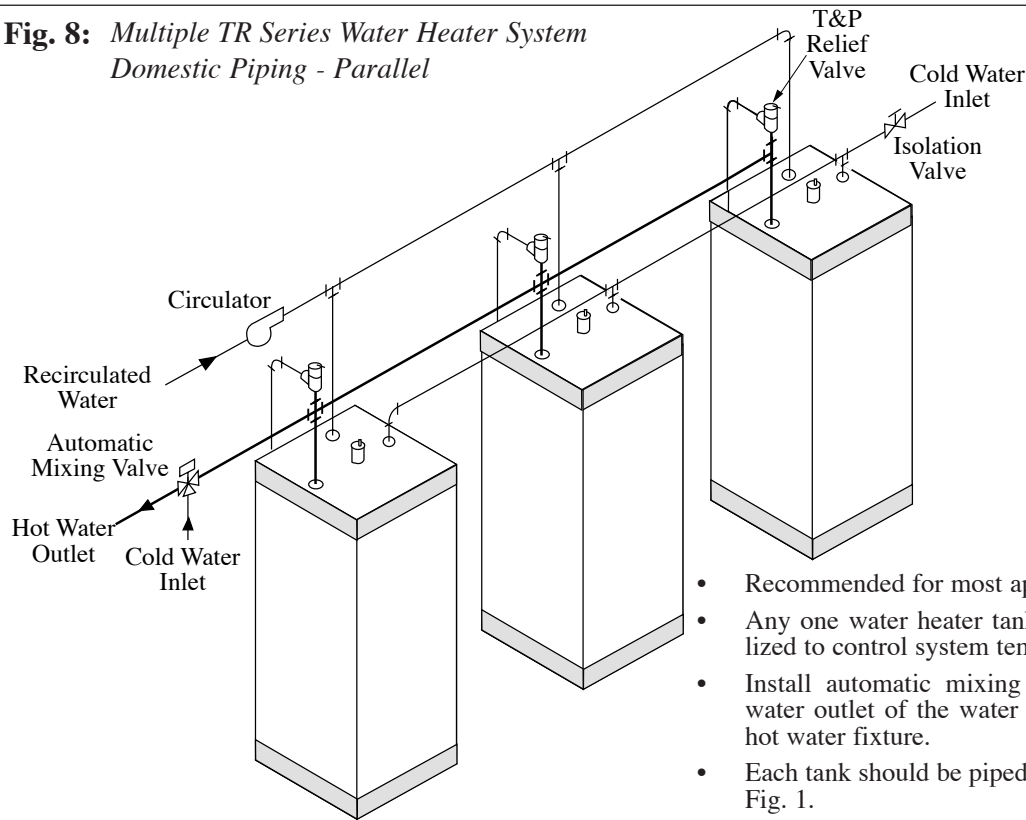

- Recommended for most applications.
- Any one water heater tank thermostat may be utilized to control system temperature.
- Install automatic mixing valve at either the hot water outlet of the water heater system or at each hot water fixture.
- Each tank should be piped with a drain as shown in Fig. 1.

Fig. 9: Multiple TR Series Water Heater System
Domestic Piping - Series

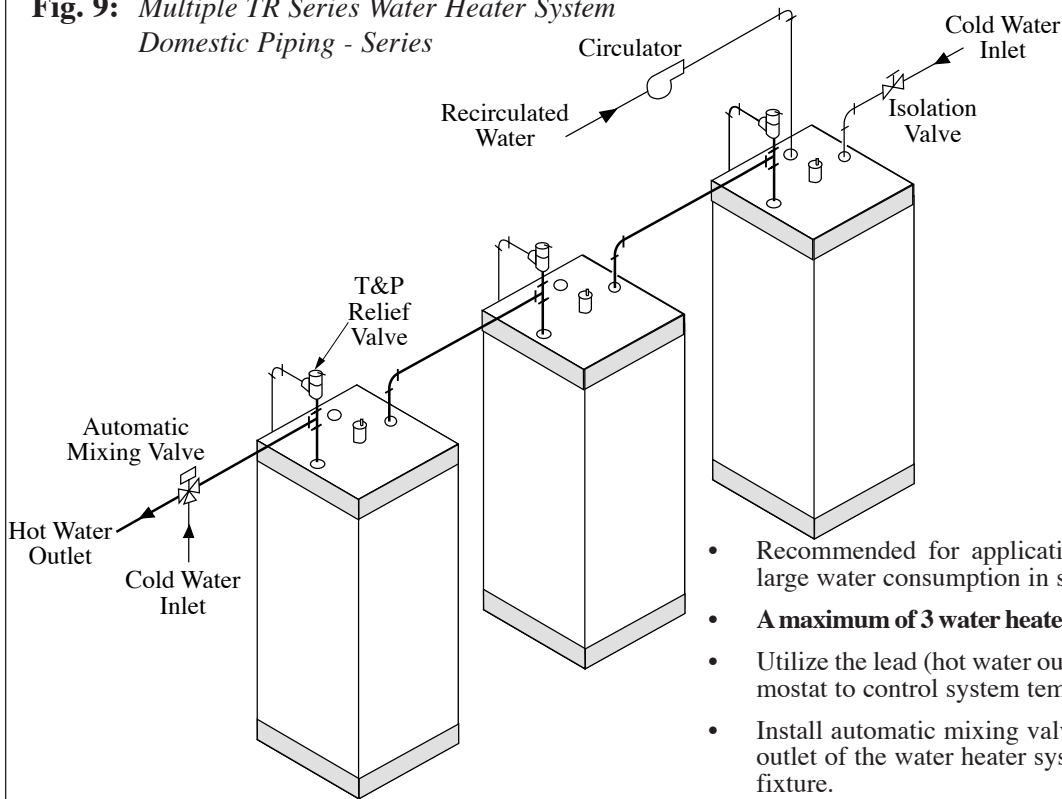

- Recommended for applications in which there is a large water consumption in short period of time.
- **A maximum of 3 water heaters may be piped in series.**
- Utilize the lead (hot water outlet) Phase III® tank thermostat to control system temperature.
- Install automatic mixing valve at either the hot water outlet of the water heater system or at each hot water fixture.
- Each tank should be piped with a drain as shown in Fig. 1.

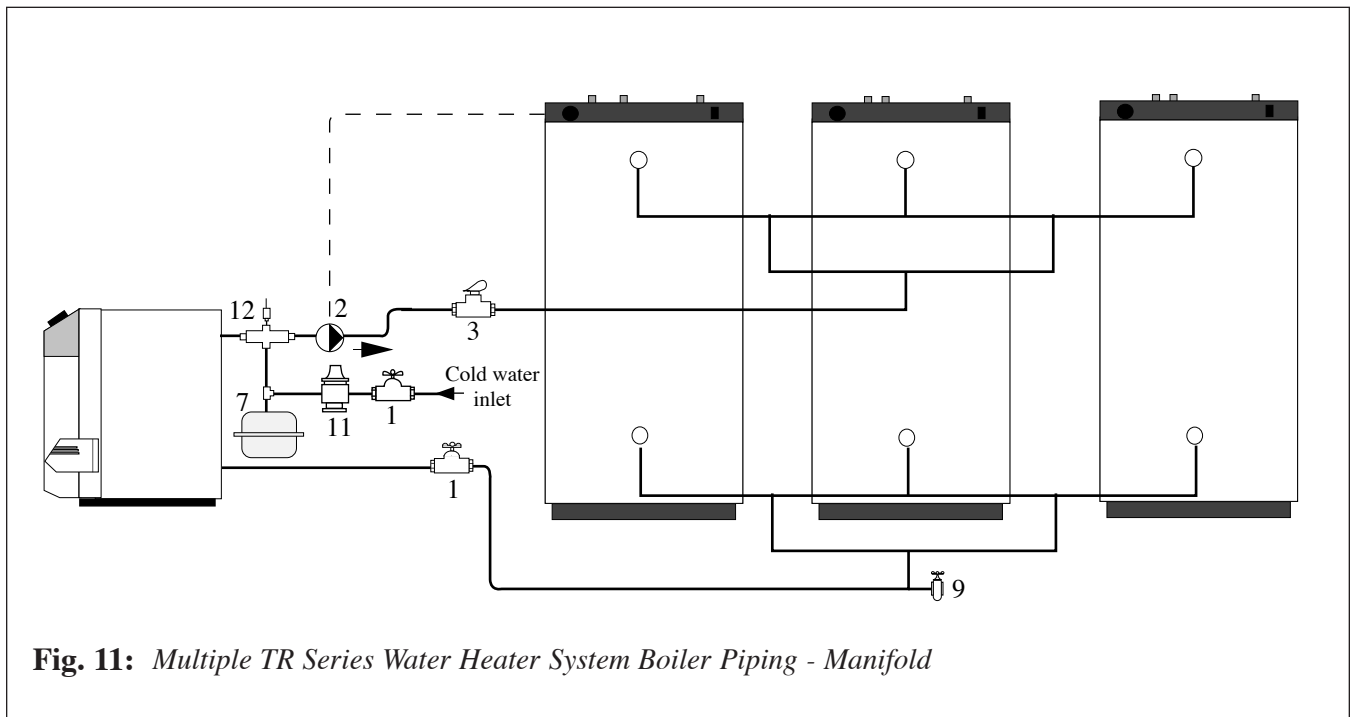
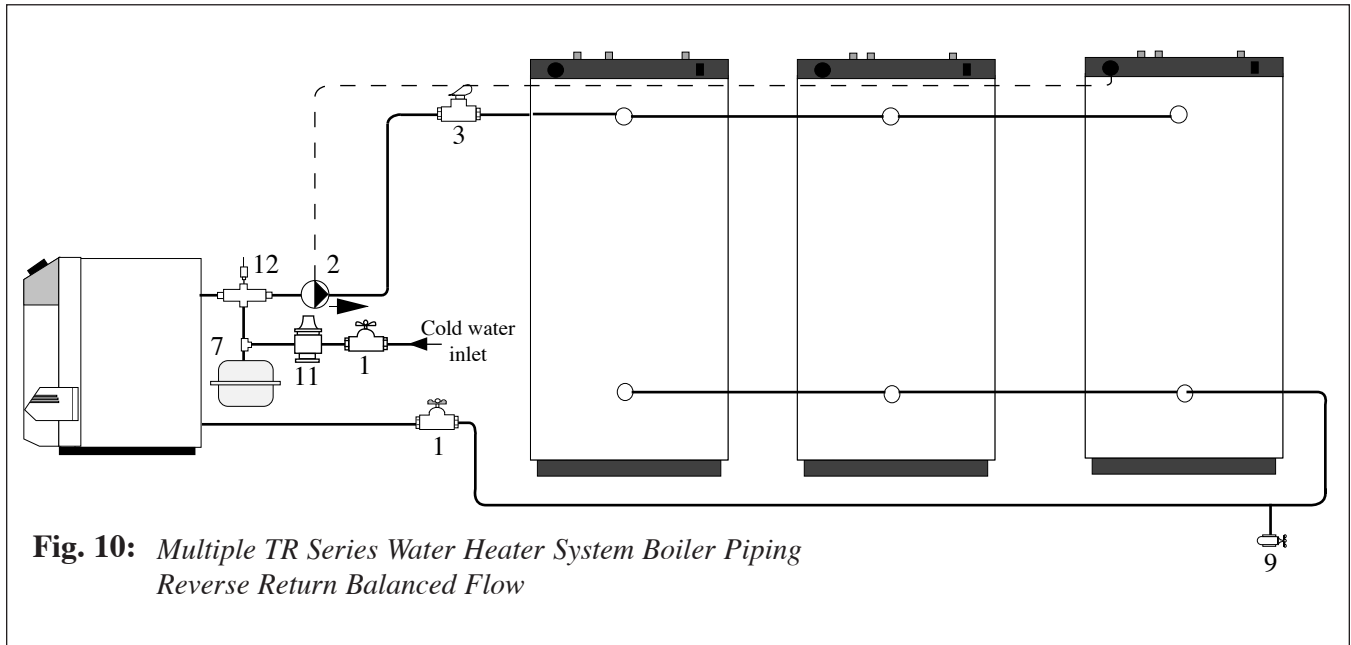

- | | |
|---------------------|-------------------|
| 1. Shut-off valves | 9. Drain valve |
| 2. Circulator | 11. Feed valve |
| 3. Flow check valve | 12. Air separator |
| 7. Expansion tank | |

Wiring Requirements

WARNING

Electrical shock hazard can cause severe personal injury, death or substantial property damage. Disconnect power before installing and/or servicing.

1. All wiring must be a minimum of 18 gauge and installed in accordance with:
 - U.S.A. - National Electrical Code and any other national, state or local code requirements having jurisdiction.
 - Canada - C.S.A. C22.1 Canadian Electrical Code Part 1 and any other national, provincial and local code requirements having jurisdiction.
2. If original wire supplied with appliance must be replaced, Type 90°C or its equivalent must be used.
3. Refer to control component instructions packed with boiler for application information.
4. An optional service switch may be installed in water heater electrical circuit. This switch would only shut off the water heater, not the home heating system. Do not shut off water heater if there is a chance of freezing.
5. All electrical contacts shown do not have power applied - off the shelf condition. See pages 16 thru 19.

Circulators

- Priority relay must be sized for total amp draw of all circulators.

Zone Valves

- Transformer must be sized for maximum load of all zone valves.

Snap Set Connection

- For easy wiring between water thermostat and boiler controls see Installation Wiring section pages 16 through 19.
- Make sure snap set is firmly snapped together after wiring.

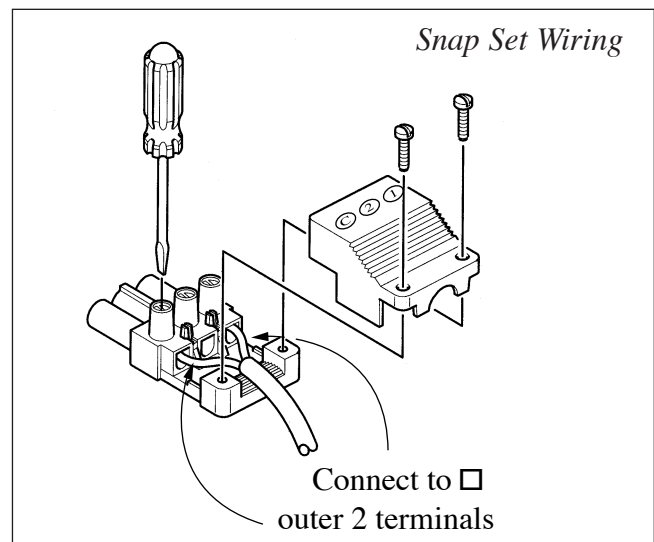

Fig. 12: Typical 4-wire Zone Valve Zoning, with Domestic Priority

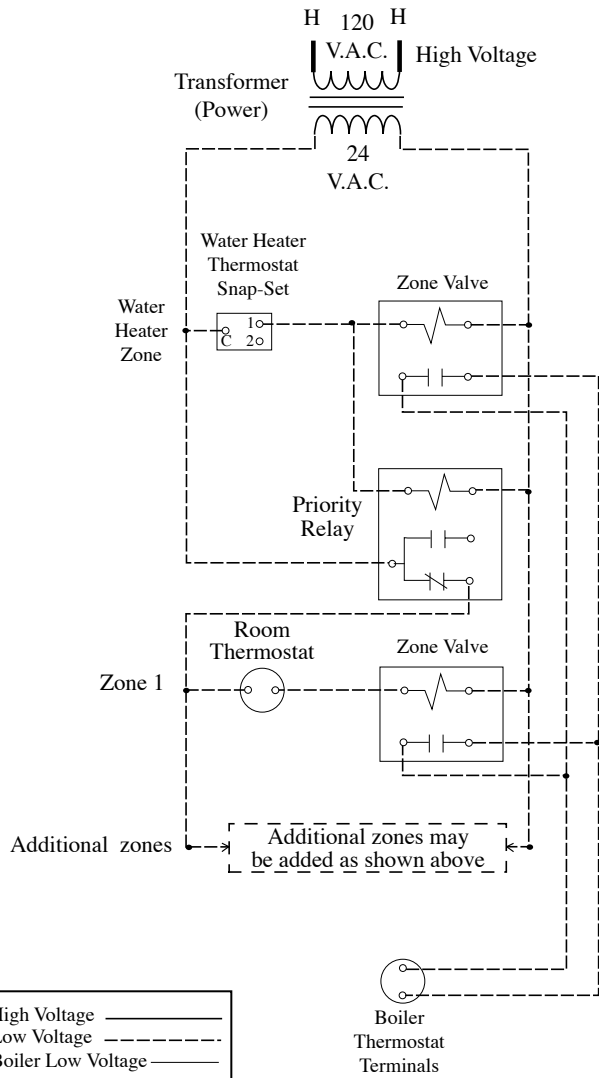

Fig. 13: Typical 3-wire Zone Valve Zoning, with Domestic Priority

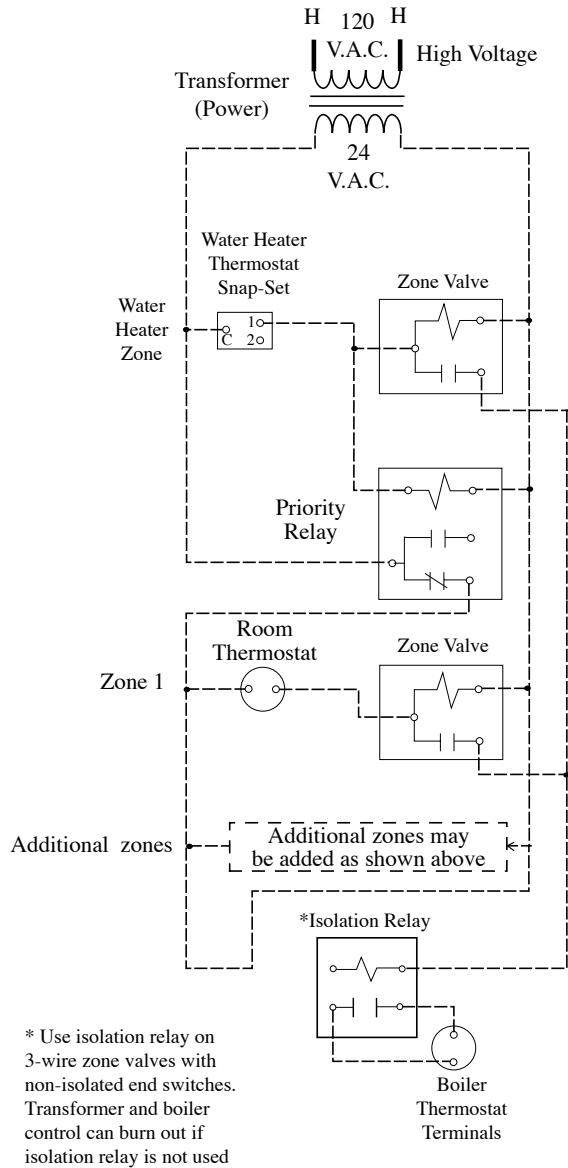

Fig. 14: Typical 4-wire Zone Valve Zoning, without Domestic Priority

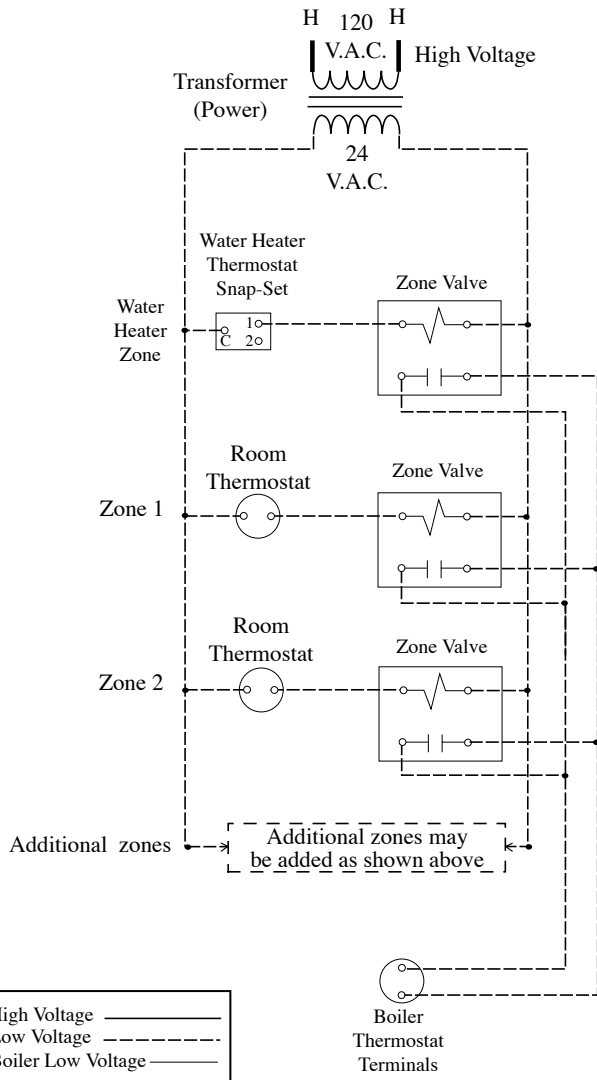

Fig. 15: Typical 3-wire Zone Valve Zoning, without Domestic Priority

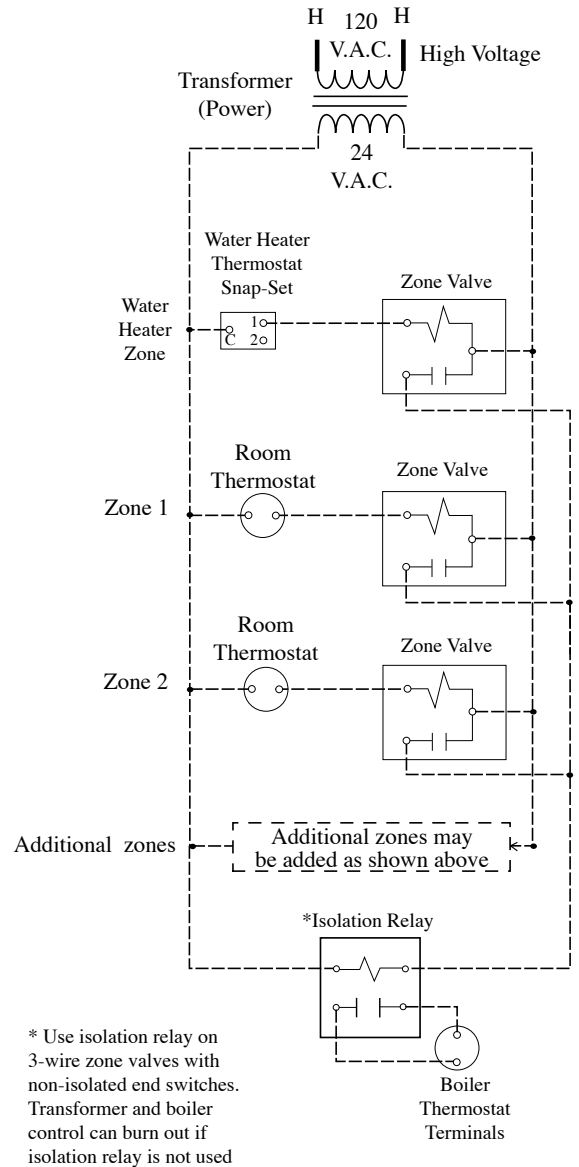

Fig. 16: Typical Circulator Zoning with Domestic Priority

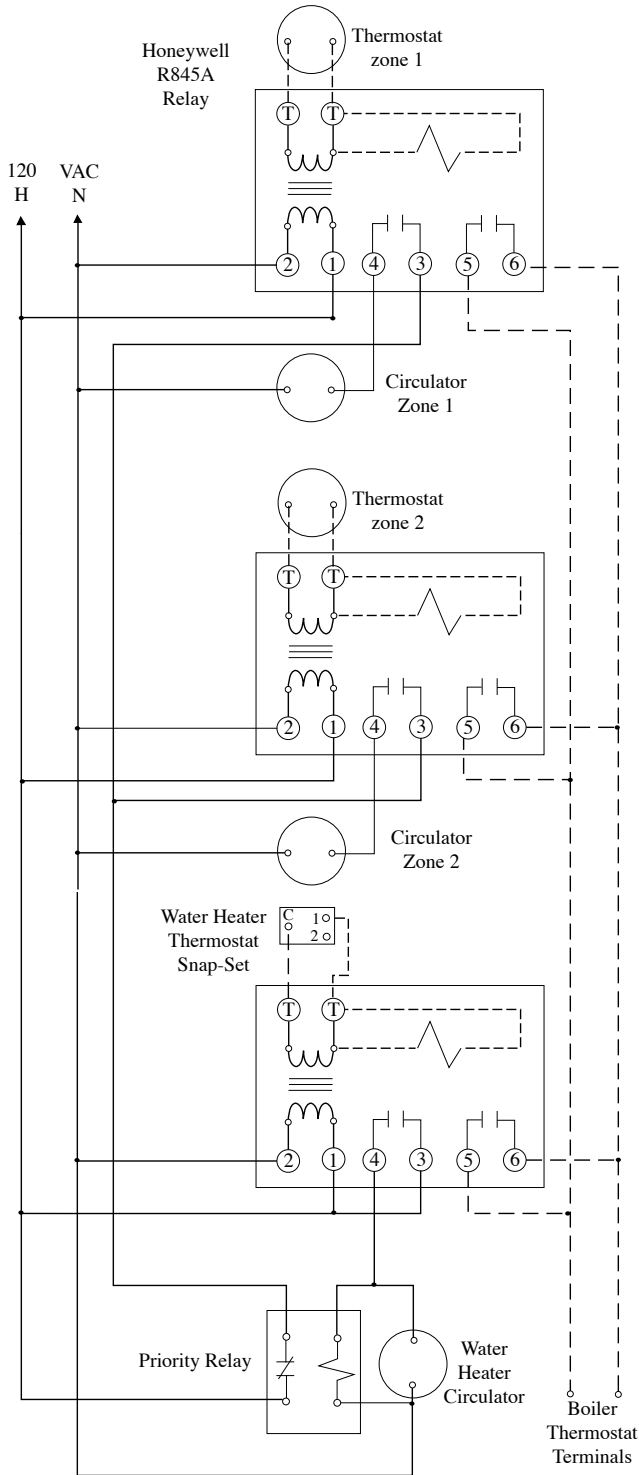

Fig. 17: Typical Circulator Zoning without Domestic Priority

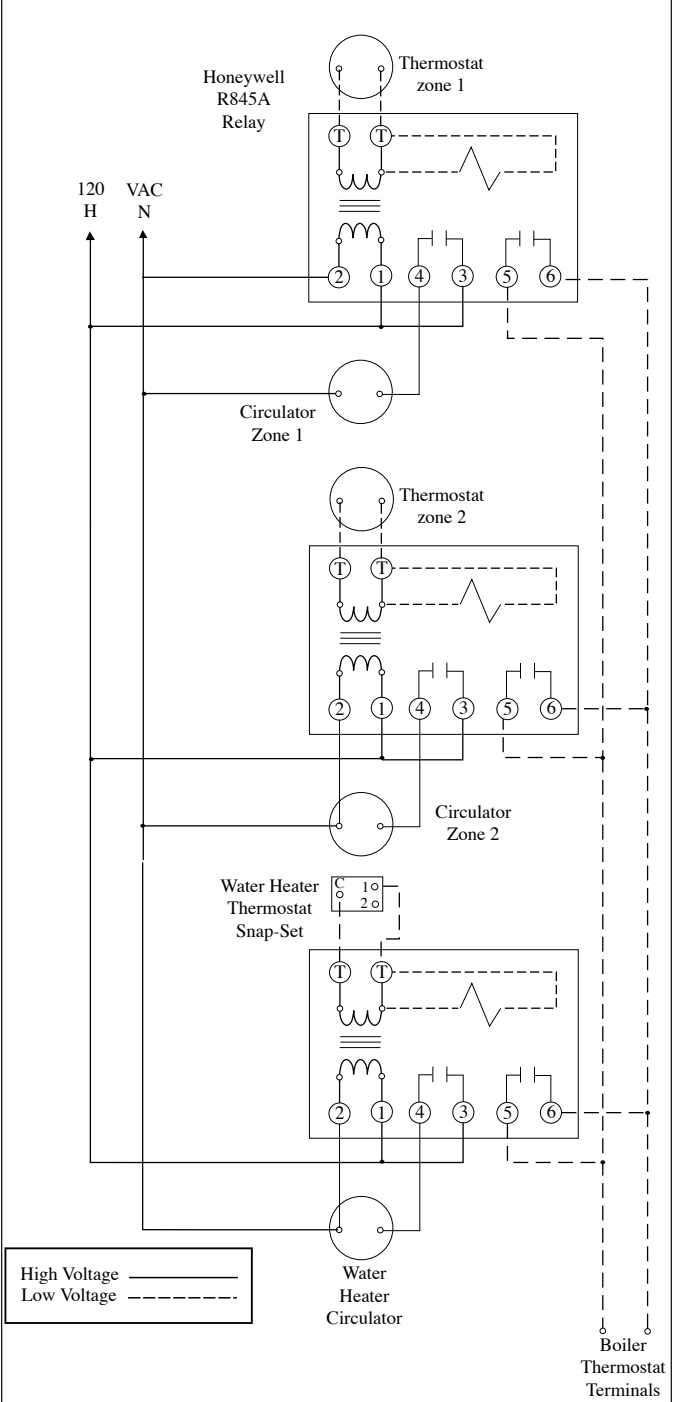
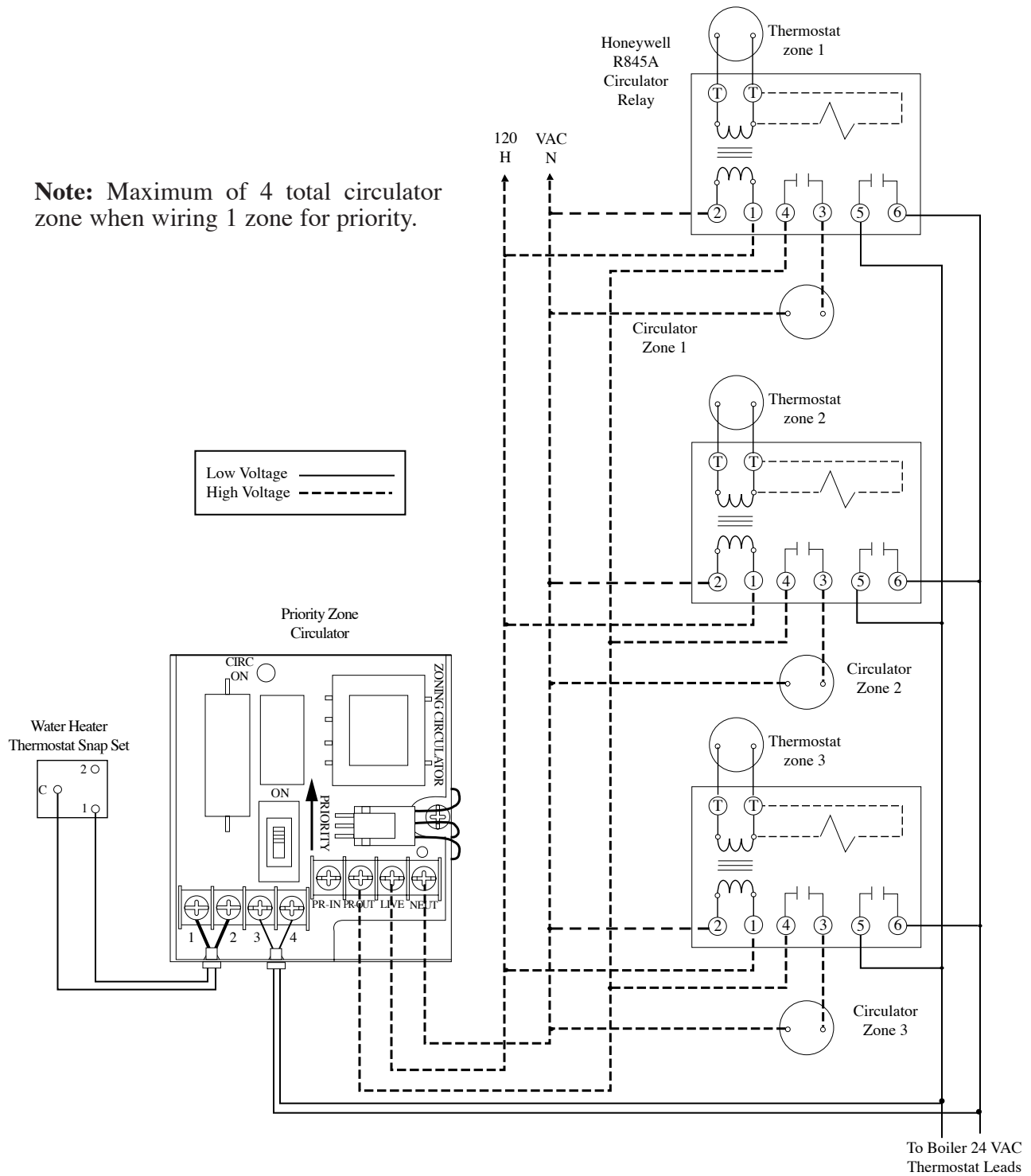

Fig. 18: Priority Zone Circulator Wiring

Note: Maximum of 4 total circulator zone when wiring 1 zone for priority.



Filling the Inner (Domestic Water) Tank

CAUTION

- Never use water heater unless inner and outer tanks are completely filled with water.
- Inner tank must be completely filled and pressurized before pressurizing outer tank.

1. Close domestic water drain valve.
2. Open domestic water isolation valves for water heater.
3. Vent air from inner (domestic water) tank by opening nearest hot water faucet. Fill domestic water tank completely by allowing water to run until there is a constant flow of water.
4. Close hot water faucet.

Filling the Outer (Boiler Water) Tank

CAUTION

- Never use water heater unless inner and outer tanks are completely filled with water.
- Inner tank must be completely filled and pressurized before pressurizing outer tank.

1. Close boiler water drain valve at boiler water outlet of water heater.
2. Open water heater's boiler water isolation valves.
3. Allow air to escape from outer (boiler water) tank by opening vent cap A on automatic air vent, located on top of water heater. See Fig. 19.
4. Follow instructions furnished with boiler to fill with water.
5. When tank is full, air will stop escaping, and the automatic air vent will close. If air vent does not seat properly (water leaks out), remove cap A. Briefly push in valve B and release it to clean valve seat. Screw cap A on completely, then unscrew one turn. See Fig. 19.

NOTICE

For proper operation of the water heater, always leave vent cap unscrewed one full turn.

6. If antifreeze is used in boiler water, check concentration. Boiler water (including additives) must be practically non-toxic, having toxicity rating or class of 1, as listed in Clinical Toxicology of Commercial Products.

WARNING

Do not use automotive, ethylene glycol or petroleum-based antifreeze. Do not use any undiluted antifreeze. This can cause severe personal injury, death or substantial property damage.

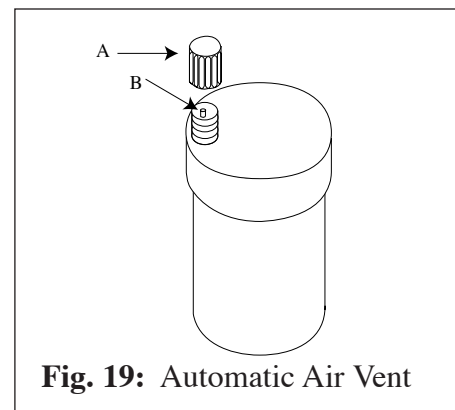

Fig. 19: Automatic Air Vent

DANGER**HOT WATER CAN SCALD!**

- Water temperatures over 125°F can cause severe burns instantly, or death from scalds.
- Feel water before bathing or showering.
- Consumer Product Safety Commission and some states recommend temperatures settings of 130°F or less. Setting thermostat higher than 130°F will increase risk of scald injury and cause severe personal injury or death.
- Water heated to a temperature suitable for clothes washing, dish washing and other sanitizing needs will scald and cause permanent injury.
- Children and elderly, infirm, or physically handicapped persons are more likely to be injured by hot water. Never leave them unattended in or near a bathtub. If anyone using hot water in the building fits this description, or if state laws or local codes require certain water temperatures at hot water faucets, take special precautions.
 - Install an automatic mixing valve at water heater or at each hot water faucet, bath and shower outlet. Selection and installation must comply with valve manufacturer's recommendation and instructions.
 - Use the lowest practical temperature setting.
 - Check water temperature after any adjustment. You must follow "Adjusting the Water Heater Thermostat" procedures.

General Notes

- Household water usage patterns will affect water temperature at any faucet or shower. Occasionally check temperature at each point of use, then adjust thermostat accordingly. Always recheck temperature after adjusting thermostat.
- When hot water is used in repeated small quantities, a "stacking" effect can develop in the water heater. The upper layer of water in tank can be hotter than lower layer.
- Lowering the thermostat setting or installing automatic mixing valves as indicated in these instructions will reduce water temperature levels. Consult your installer or service technician.

WARNING

At no time should boiler limit control be set above 210°F. This can cause severe personal injury, death or substantial property damage if ignored.

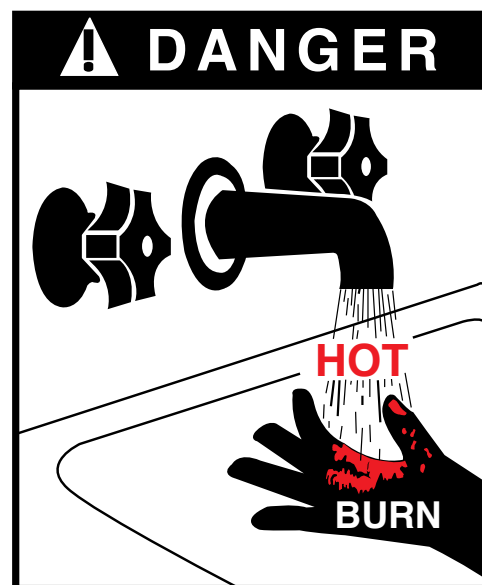

Adjusting the Water Heater Thermostat

Water heater thermostat is factory set to its lowest temperature. This may or may not be suitable for your needs.

Turn thermostat knob **clockwise**  to **increase** water temperature.

Turn thermostat knob **counter-clockwise**  to **decrease** water temperature.

- Check water temperature at a hot water faucet immediately after first heating cycle. Further temperature adjustment may be necessary as water heating system is used. Recheck water temperature at faucet after adjustment.
- When adjusting thermostat, be sure boiler limit control is set a minimum of 20°F higher.

WARNING

Studies have indicated that dangerous bacteria, including legionella, pneumophila, can form in the potable water distribution system if certain minimum water temperatures are not maintained. Contact your local health department for more information.

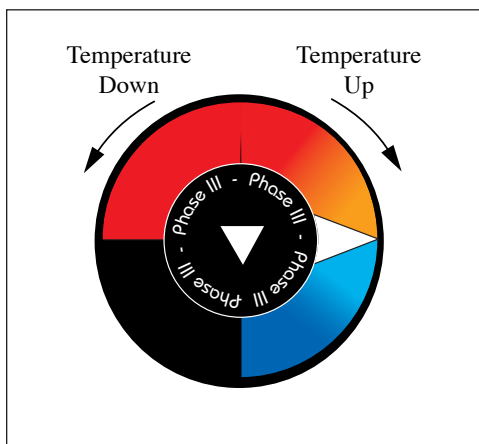

TR Series Knob

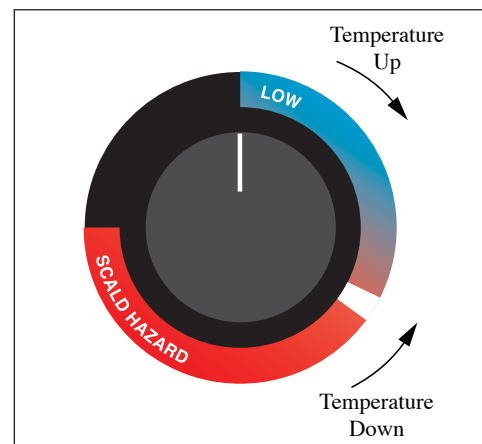

SMART Series Knob

Maintenance Schedule

Annual service by qualified service technician should include the following:

- ☒ Any procedure required by local codes.
- ☒ Check air vent operation.
- ☒ Verify system pressure. Air venting procedure may require adding water to bring system up to pressure, typically 12 psig.
- ☒ Manually operate T&P relief valve at least once a year. This will release some hot water.

WARNING

Before operating T&P relief valve, make sure no one is in front of or around T&P relief valve discharge piping. Hot discharge water can cause severe personal injury or substantial property damage.

- ☒ Move operating lever to open position for a few seconds and then move it back, allowing it to snap closed. After T&P relief valve is operated, if it continues to release water, close cold water inlet to water heater immediately. Follow draining instructions, and replace T&P relief valve. If T&P relief valve weeps periodically, it may be due to thermal expansion see Thermal Expansion, page 5. Do not plug T&P relief valve or discharge piping.

DANGER

Plugging T&P relief valve or discharge piping can cause excessive pressure in water heater, resulting in severe personal injury, death, or substantial property damage.

- ☒ Follow instructions on circulator to oil it, if required.
- ☒ Check mixing valve, valves, pipes and fittings for leaks.
- ☒ Check function of field-installed controls and valves. See component manufacturer's instructions.

- ☒ Review homeowner's maintenance responsibilities and their frequencies, including any not listed in the following section.

Homeowner monthly maintenance to include:

- ☒ Check air vent operation.
 - Automatic air vent - remove cap. Briefly push in valve and release it to clean valve seat. Screw cap on completely, then unscrew one full turn. If air vent does not operate, call qualified service technician.
- ☒ Visually check valves, pipes and fittings for leaks. Call qualified service technician to repair leaks.

Filling Water Heater

See "Filling the Inner (Domestic Water) Tank and "Filling the Outer (Boiler Water) Tank" on page 20.

Draining Water Heater

Drain water heater if it will be shut off and exposed to freezing temperatures. Freezing water will expand and damage water heater.

- If boiler water contains sufficient antifreeze, then only the domestic water needs to be drained.

WARNING

Close boiler water isolation valves and relieve system pressure to below 15 psig in outer tank before draining inner tank to prevent damage to inner tank.

- If boiler water does not contain sufficient antifreeze, then the boiler water and domestic water must be drained.

If antifreeze is used in boiler water, check concentration. Boiler water (including additives) must be practically non-toxic, having toxicity rating or class of 1, as listed in Clinical Toxicology of Commercial Products. A maximum 50/50 mixture of inhibited propylene glycol is recommended. Follow antifreeze manufacturer's instruction.

WARNING

Do not use automotive, ethylene glycol or petroleum-based antifreeze. Do not use any undiluted antifreeze. This can cause severe personal injury, death or substantial property damage.

WARNING

Water from opened drain valves, unions and other connections may be extremely hot. To avoid severe personal injury, death or substantial property damage:

- **Tighten all drain hose connections.**
- **Direct hot water away from all persons.**

Draining Inner (Domestic Water) Tank

(See Domestic Piping Fig. 1 page 8)

1. Disconnect power supply to water heater.
 - If outer (boiler water) tank pressure is greater than 15 psig, relieve boiler pressure and close isolation valves before proceeding.

2. Close system supply isolation valve.
3. Connect a hose to domestic water drain valve at cold water inlet. Hose should extend to drain at floor level to allow siphoning of domestic water tank.
4. Open hot water faucet at highest point above heater.
5. Open domestic water drain valve to start siphoning.
6. When draining is complete, close hot water faucet and domestic water drain valve.

Draining Outer (Boiler Water) Tank

1. Disconnect power supply to water heater.
2. Close boiler water isolation valves between boiler and water heater.
3. Connect hose to boiler water drain valve at water heater. Open and drain water to a safe place.
4. To speed draining procedure, loosen air vent on top of tank.
5. When draining is complete, close drain valve and retighten air vent.

TR SERIES

TR-20/30/36/80/100/120

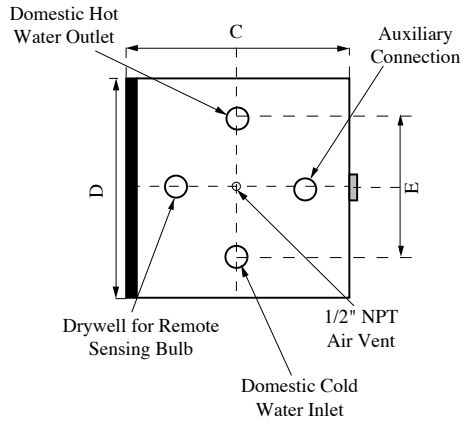

TR-45/60

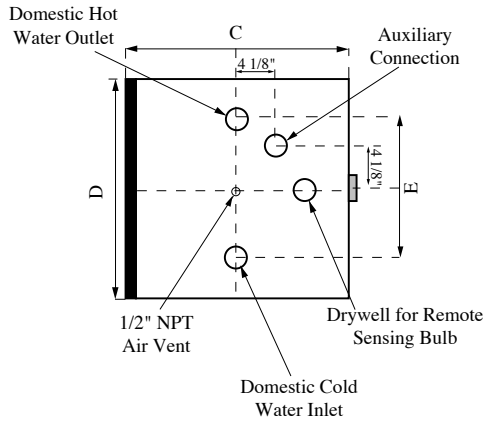

Top views

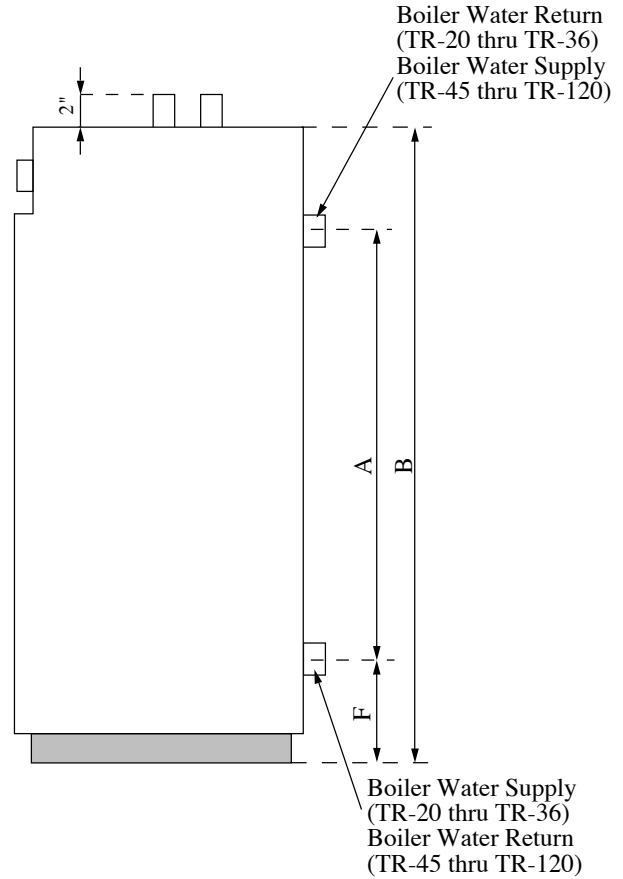

Side view

MODEL		TR-20	TR-30	TR-36	TR-45	TR-60	TR-80	TR-100	TR-120
Capacity	Gal								
Domestic Boiler		20	30	36	46	56	76	95	119
Heating surface	Sq. Ft.	8	9	12	8	8	15	25	30
Head loss boiler side	Ft.	3/4	3/4	1	1 1/4	1 1/2	2	2	2 1/2
Piping connections	Inches								
Domestic	ø	3/4	3/4	3/4	3/4	1	1 1/2	1 1/2	1 1/2
Boiler	ø	1	1	1	1 1/4	1 1/4	2	2	2
Recirculation	ø	3/4	3/4	3/4	3/4	1	1 1/2	1 1/2	1 1/2
Dimensions	Inches								
A		14	32	42	39	49	42	53	52
B		38	49	60	57	67	62	72	72
C		19	19	19	23	23	24	26	30
D		19	19	19	23	23	24	27	30
E		7 3/4	7 3/4	7 3/4	14	14	10 3/4	10 3/4	10 3/4
F		10	10	10	10	10	12	12	12
Drywell length	Inches	31	39	51	39	51	51	51	51
Empty weight	Lbs	110	165	180	194	220	368	390	450

SMART SERIES

Specifications

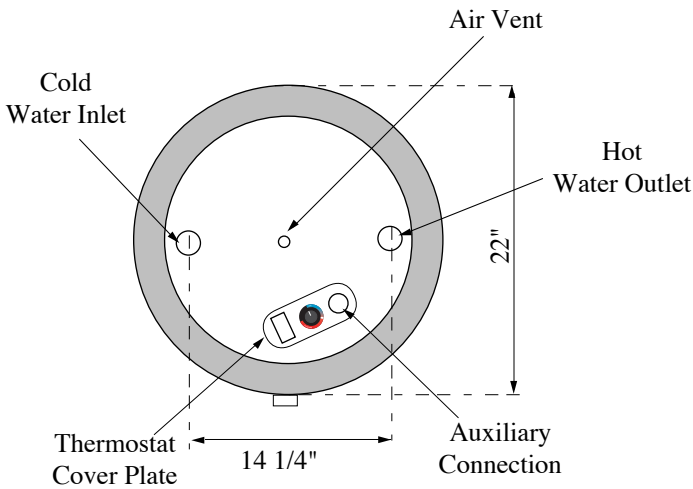

Top view SMART-20/30/40/50/60

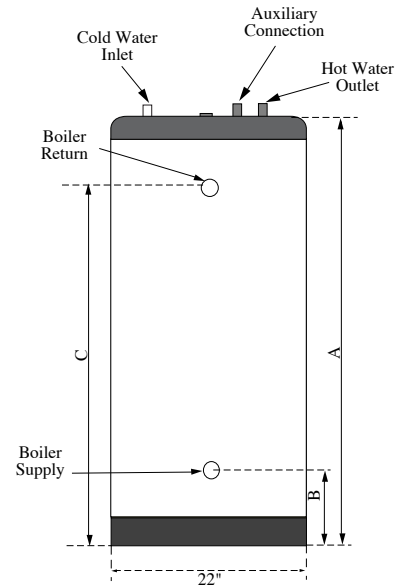

Rear view SMART-20/30/40/50/60

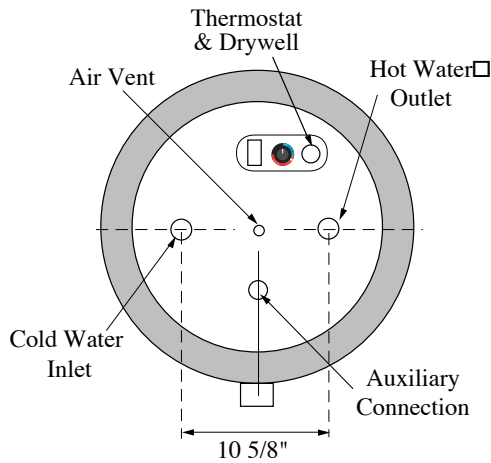

Top view SMART 80/100

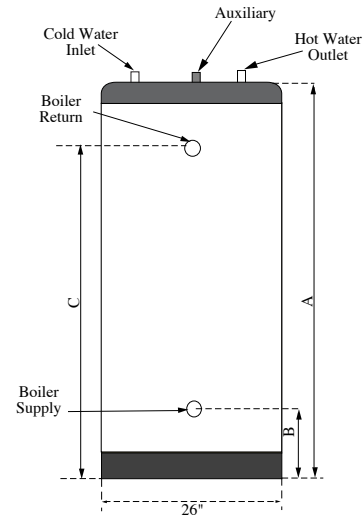

Rear view SMART 80/100

Model		Smart 20	Smart 30	Smart 40	Smart 50	Smart 60	Smart 80	Smart 100
Capacity	Gal.							
Domestic		22	28	36	46	56	70	95
Boiler		5	5	6	8	8	14	25
Heating surface	Sq. Ft.	11	13	16	20	24	29	36
Head loss boiler side	Ft.	3/4	3/4	1	1 1/4	1 1/2	2	2
Piping connections	Inches							
Domestic	ø	3/4	3/4	3/4	3/4	3/4	1 1/2	1 1/2
Boiler	ø	1	1	1	1 1/4	1 1/4	1 1/2	1 1/2
Auxiliary	ø	3/4	3/4	3/4	3/4	3/4	1 1/2	1 1/2
Dimensions	Inches							
Diameter		22	22	22	22	22	26	26
A		32	38	46	57	66	61	78
B		9	9	9	9	9	10	10
C		24	30	38	49	58	50 1/2	50 1/2
Drywell length	Inches	25 1/2	29 1/2	37 1/2	37 1/2	47 1/2	47 1/2	51
Empty weight	Lbs.	100	115	135	165	190	315	390

Model	Boiler Heating Capacity MBH	Peak Flow Gal./10 min.	1st Hour Flow Gal./Hour	Continuous Flow Gal./Hour	Circulator Min. GPM
TR-20	80	35	125	110	5
TR-30	87	45	140	115	6
TR-36	118	55	190	160	8
TR-45	137	70	220	185	9
TR-60	270	110	410	360	18
TR-80	337	135	510	450	22
TR-100	375	160	575	500	25
TR-120	420	190	650	560	28
Model	Boiler Heating Capacity MBH	Peak Flow Gal./10 min.	1st Hour Flow Gal./Hour	Continuous Flow Gal./Hour	Circulator Min. GPM
SMART 20	70	35	110	95	5
SMART 30	76	40	125	100	5
SMART 40	106	50	170	140	7
SMART 50	121	65	200	160	8
SMART 60	243	100	370	325	16
SMART 80	285	120	435	380	18
SMART 100	337	150	525	450	25

Conditions: 50° F Domestic Cold Water Inlet Temperature
140°F Domestic Hot water Outlet Temperature
200°F Boiler Water Supply Temperature

Model	Boiler Heating Capacity MBH	Peak Flow Gal./10 min.	1st Hour Flow Gal./Hour	Continuous Flow Gal./Hour	Circulator Min. GPM
TR-20	105	50	210	190	7
TR-30	120	60	245	220	8
TR-36	145	75	300	270	10
TR-45	190	95	390	350	13
TR-60	335	150	665	620	22
TR-80	365	175	730	670	24
TR-100	400	200	825	750	28
TR-120	445	235	915	820	30
Model	Boiler Heating Capacity MBH	Peak Flow Gal./10 min.	1st Hour Flow Gal./Hour	Continuous Flow Gal./Hour	Circulator Min. GPM
SMART 20	95	50	195	175	6
SMART 30	115	60	235	210	8
SMART 40	130	70	270	240	9
SMART 50	180	95	370	330	12
SMART 60	320	145	635	590	21
SMART 80	340	165	690	630	24
SMART 100	380	185	775	700	26

Conditions: 50° F Domestic Cold Water Inlet Temperature
115°F Domestic Hot water Outlet Temperature
200°F Boiler Water Supply Temperature

TR Series

Code	Description	Model
P3AVT01	Air Vent (automatic)	ALL
P3KITTH01	Aquastat	ALL
P3BP01	Base Plate	TR-20/30/36
P3BP02	Base Plate	TR-45/60
P3BP03	Base Plate	TR-75
P3BP04	Base Plate	TR-100/120
P3CS01	Control Panel	TR-20/30/36
P3CS02	Control Panel	TR-45/60
P3CS03	Control Panel	TR-80
P3CS05	Control Panel	TR-100
P3CS04	Control Panel	TR-120
P3DT02	Dip Tube	TR-20
P3DT04	Dip Tube	TR-30
P3DT10	Dip Tube	TR-36
P3DT05	Dip Tube	TR-45
P3DT06	Dip Tube	TR-60
P3DT08	Dip Tube	TR-80
P3DT09	Dip Tube	TR-100/120
P3DNK01	Drain Kit	ALL
P3DWT01	Drywell	TR-20
P3DWT02	Drywell	TR-30
P3DWT04	Drywell	TR-36
P3DWT02	Drywell	TR-45
P3DWT03	Drywell	TR-60
P3DWT04	Drywell	TR-80
P3DWT04	Drywell	TR-100
P3DWT04	Drywell	TR-120
P3JKT20F	Jacket, Front Panel	TR-20
P3JKT30F	Jacket, Front Panel	TR-30
P3JKT36F	Jacket, Front Panel	TR-36
P3JKT45F	Jacket, Front Panel	TR-45
P3JKT60F	Jacket, Front Panel	TR-60
P3JKT75F	Jacket, Front Panel	TR-80
P3JKT100F	Jacket, Front Panel	TR-100
P3JKT120F	Jacket, Front Panel	TR-120
P3JKT20B	Jacket, Back Panel	TR-20
P3JKT30B	Jacket, Back Panel	TR-30
P3JKT36B	Jacket, Back Panel	TR-36
P3JKT45B	Jacket, Back Panel	TR-45
P3JKT60B	Jacket, Back Panel	TR-60
P3JKT75B	Jacket, Back Panel	TR-80
P3JKT100B	Jacket, Back Panel	TR-100
P3JKT120B	Jacket, Back Panel	TR-120
P3JKT20L	Jacket, Left Panel	TR-20
P3JKT30L	Jacket, Left Panel	TR-30
P3JKT36L	Jacket, Left Panel	TR-36
P3JKT45L	Jacket, Left Panel	TR-45
P3JKT60L	Jacket, Left Panel	TR-60
P3JKT75L	Jacket, Left Panel	TR-80
P3JKT100L	Jacket, Left Panel	TR-100
P3JKT120L	Jacket, Left Panel	TR-120
P3JKT20R	Jacket, Right Panel	TR-20
P3JKT30R	Jacket, Right Panel	TR-30
P3JKT36R	Jacket, Right Panel	TR-36
P3JKT45R	Jacket, Right Panel	TR-45
P3JKT60R	Jacket, Right Panel	TR-60
P3JKT75R	Jacket, Right Panel	TR-80
P3JKT100R	Jacket, Right Panel	TR-100
P3JKT120R	Jacket, Right Panel	TR-120
P3LD01	Lid	TR-20/30/36
P3LD02	Lid	TR-45/60
P3LD03	Lid	TR-80
P3LD04	Lid	TR-120
P3LD05	Lid	TR-100
P3THR01	Thermometer	ALL
P3WRS01	Wire Harness & Snap Set	ALL

SMART Series

Code	Description	Model
P3AVT01	Air Vent (automatic)	ALL
P3KITTH01	Aquastat	ALL
P3BTMH3	Bottom Cap	SMART 20-60
P3BTMH2	Bottom Cap	SMART 80/100
P3TOPH3	Top Cap	SMART 20-60
P3TOPH2	Top Cap	SMART 80/100
P3CTNH20	Carton	SMART 20-60
P3CTNH30	Carton	SMART 20-60
P3CTNH36	Carton	SMART 20-60
P3CTNH45	Carton	SMART 20-60
P3CTNH60	Carton	SMART 20-60
P3CTNH80	Carton	SMART 80/100
WMDT01	Dip Tube with Diffuser	SMART 20
WMDT01	Dip Tube with Diffuser	SMART 30
WMDT02	Dip Tube with Diffuser	SMART 40
WMDT03	Dip Tube with Diffuser	SMART 50
WMDT04	Dip Tube with Diffuser	SMART 60
PEDT08	Dip Tube	SMART 80/100
P3DWH20	Dry Well	SMART 20
P3DW01	Dry Well	SMART 30
P3DW02	Dry Well	SMART 40
P3DW03	Dry Well	SMART 50
P3DW03	Dry Well	SMART 60
P3DW04	Dry Well	SMART 80/100

TR _____ or equal

1. Hot water tank designed for production of domestic hot water using hot water as heating source. The principle consists of two concentric tanks. The inner tank contains domestic hot water and the outer tank contains heating system water. The inner tank shall have a capacity of _____ gallons.
2. The inner tank material shall be 304L corrugated stainless steel or higher corrosion resistance stainless steel, and have a working pressure of 150 psi or more. The cold water connection into this tank shall extend to near the bottom of the tank. The hot water connection shall be at the top of the tank. Tank shall be designed to be self descaling.
3. The outer tank material shall be carbon steel with a built in air vent. The working pressure shall be 45 psi maximum.
4. The tank shall have a minimum of _____ square feet of heat transfer surface.
5. The outer tank shall have a minimum of 2 inches of polyurethane foam insulation or insulation with an equivalent "R" factor value installed on all sides.
6. The tanks shall be installed in a steel cabinet which has been finished with a baked enamel paint.
7. The inner tank shall be equipped with a dry well. In the dry well shall be a remote sensing bulb to indicate water temperature in the tank, and an additional remote sensing bulb for a low voltage thermostat. The thermostat should be adjustable from low to high temperature. The thermostat shall open the circuit when the temperature rises above the set point and shall close when the temperature has no more than a (6) degree differential between the opening temperature and the closing temperature.
8. Tank shall be installed with a temperature/pressure relief valve. Valve shall relieve pressure at 150 psi. Relief temperature shall be 210 degrees.

SMART _____ or equal

1. Hot water tank designed for production of domestic hot water using hot water as heating source. The principle consists of two concentric tanks. The inner tank contains domestic hot water and the outer tank contains heating system water. The inner tank shall have a capacity of _____ gallons.
2. The inner tank material shall be 304L corrugated stainless steel or higher corrosion resistance stainless steel, and have a working pressure of 150 psi or more. The cold water connection into this tank shall extend to near the bottom of the tank. The hot water connection shall be at the top of the tank. Tank shall be designed to be self descaling.
3. The outer tank material shall be carbon steel with a built in air vent. The working pressure shall be 45 psi maximum.
4. The tank shall have a minimum of _____ square feet of heat transfer surface.
5. The outer tank shall have a minimum of 2 inches of water blown polyurethane insulation or insulation with an equivalent "R" factor value installed on all sides.
6. The tanks shall be covered by a plastic exterior jacket.
7. The inner tank shall be installed with a dry well. In the dry well shall be a remote sensing bulb for a low voltage thermostat. The thermostat should be adjustable from low to high temperature. The thermostat shall open the circuit when the temperature rises above the set point and shall close when the temperature has no more than a (6) degree differential between the opening temperature and the closing temperature.
8. Tank shall be installed with a temperature/pressure relief valve. Valve shall relieve pressure at 150 psi. Relief temperatures shall be 210 degrees.

Additional quality water heating equipment available from: **Triangle Tube/Phase III**

Phase III HM Series Water Heaters



- Stainless steel construction
- Oil and Gas fired
- A unique design that eliminates the problem of scaling found with traditional water heaters
- Inputs ranging from 100,000 BTU/hr to 382,000 BTU/hr
- Capable of 180° continuous production
- 10 year non-prorated warranty
- ETL Laboratories listed
- ASME version available

TTP Brazed Plate Heat Exchangers



- For domestic water, snow melting, radiant floor, refrigeration
- Plates made of stainless steel, with a 99.9 % copper and brazed, ensuring a high resistance to corrosion
- Self cleaning and self descaling
- Computerized sizing available from Triangle Tube/Phase III
- Available in capacities from 25,000 BTU/hr to 5,000,000 BTU/hr
- UL Listed

Maxi-flo Pool and Spa Heat Exchangers



- Construction of high quality corrosion resistant stainless steel (AISI 316)
- Specially designed built-in flow restrictor to assure maximum heat exchange
- Compact and light weight
- Available in 5 sizes that can accommodate any size pool or spa



Freeway Center - 1 Triangle Lane - Blackwood, NJ 08012
(856) 228 8881 Fax (856) 228 3584
<http://www.triangletube.com> / e-mail: sales@triangletube.com.

