

INSTALLER: LEAVE THIS MANUAL WITH THE APPLIANCE.  
CONSUMER: RETAIN THIS MANUAL FOR FUTURE REFERENCE.



# INSTALLATION AND OPERATING INSTRUCTIONS

CERTIFIED UNDER U.S. ENVIRONMENTAL PROTECTION AGENCY (E.P.A.) JULY 1990 40 C.F. R. PART 60 AND THE OREGON DEPARTMENT OF ENVIRONMENTAL QUALITY (D.E.Q.) PARTICULATE EMISSION STANDARDS BY E.E.M.C THESE STOVES HAVE BEEN TESTED AND LISTED BY INTERTEK TESTING SERVICES TO STANDARDS: CSA B366.2, ULC S627, UL 1482.

## TI-2201 WOOD INSERT

### SAFETY INFORMATION

#### **WARNING**

If the information in these instructions is not followed exactly, a fire or explosion may result causing property damage, personal injury or death. Improper installation, adjustment, alteration, service or maintenance can cause injury or property damage, bodily injury or even death. Please read entire manual before you install and use your appliance.

- This appliance can be very hot when burning.
- Combustible materials such as firewood, wet clothing, etc. placed too close can catch fire.
- Children and pets must be kept from touching the appliance when it is hot.
- The chimney must be sound and free of cracks. Before installing this unit, contact the local building or fire authority and follow their guidelines.
- Operate only with the door tightly closed.
- Burn wood behind the log retainer directly on the firebricks.
- Do not use an elevated grate or otherwise raise the fire.
- At least 14 square inches of outside air must be admitted to the room or directly to the unit through a 4" diameter pipe.
- This appliance is designed to burn natural wood only. Higher efficiencies and lower emissions generally result when burning air dried seasoned hardwoods, as compared to softwoods or to green or freshly cut hardwoods.
- Do not start a fire with chemicals or fluids such as gasoline, engine oil, etc.
- Do not burn treated wood, coal, charcoal, coloured paper, cardboard, solvents or garbage.
- Do not let the appliance become hot enough for any part to glow red.
- KEEP THE STOVE TOP TEMPERATURE BELOW 700°F (371°C). Attempts to achieve heat output rates that exceed design specifications can result in steel distortion and damage.

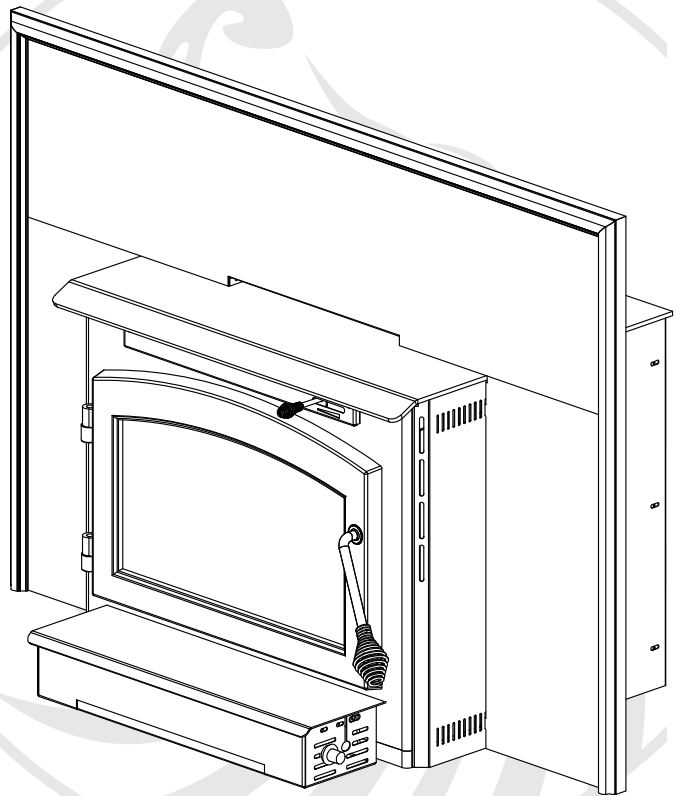

APPLY SERIAL NUMBER LABEL FROM CARTON



Serial No. XXXXXX000000  
MODEL NO.

Wolf Steel Ltd., 24 Napoleon Rd., Barrie, ON, L4M 4Y8 Canada /  
103 Miller Drive, Crittenden, Kentucky, USA, 41030

Phone (705)721-1212 • Fax (705)722-6031 • www.timberwolffireplaces.com • ask@timberwolffireplaces.com

# TABLE OF CONTENTS

<b>1.0</b>	<b>INSTALLATION OVERVIEW</b>	<b>3</b>
<b>2.0</b>	<b>INTRODUCTION</b>	<b>4</b>
	2.1 DIMENSIONS (COMPLETE WITH FLASHING)	5
	2.2 SPECIFICATIONS	5
	2.3 GENERAL INSTRUCTIONS	5
	2.4 GENERAL INFORMATION	6
	2.5 RATING PLATE LOCATION	8
<b>3.0</b>	<b>INSTALLATION PLANNING</b>	<b>9</b>
	3.1 MINIMUM CLEARANCE TO COMBUSTIBLES	9
<b>4.0</b>	<b>INSTALLATION</b>	<b>10</b>
	4.1 TYPICAL EXISTING MASONRY	11
	4.2 FACTORY BUILT FIREPLACE	12
<b>5.0</b>	<b>FINISHING</b>	<b>13</b>
	5.1 SECONDARY AIR TUBES	13
	5.2 BRICKS AND BAFFLES INSTALLATION	14
	5.3 DOOR INSTALLATION	14
	5.4 DOOR HANDLE INSTALLATION	15
	5.5 FLASHING INSTALLATION	16
	5.6 BLOWER INSTALLATION	17
<b>6.0</b>	<b>OPERATION</b>	<b>18</b>
	6.1 AIR CONTROL	19
	6.2 FIRE EXTINGUISHERS / SMOKE DETECTORS	19
	6.3 FUEL	19
	6.4 LIGHTING A FIRE	20
	6.4.1 FLASH FIRE	20
	6.4.2 EXTENDED FIRE	20
	6.5 SMOKING	20
<b>7.0</b>	<b>MAINTENANCE</b>	<b>21</b>
	7.1 ASH REMOVAL PROCEDURES	21
	7.2 CREOSOTE FORMATION AND REMOVAL	21
	7.3 RUNAWAY OR CHIMNEY FIRE	22
	7.4 CHIMNEY CLEANING	22
	7.5 DOOR REMOVAL	23
	7.6 GLASS REPLACEMENT	23
	7.7 CARE OF GLASS	24
	7.8 CARE OF PLATED PARTS	24
	7.9 GASKET REPLACEMENT	24
	7.10 BLOWER SERVICE OR REPLACEMENT	25
	7.11 WOOD	25
<b>8.0</b>	<b>REPLACEMENTS</b>	<b>26</b>
<b>9.0</b>	<b>TROUBLE SHOOTING</b>	<b>28</b>
<b>10.0</b>	<b>WARRANTY</b>	<b>30</b>
<b>11.0</b>	<b>SERVICE HISTORY</b>	<b>31</b>
<b>12.0</b>	<b>NOTES</b>	<b>32</b>

**NOTE:** Changes, other than editorial, are denoted by a vertical line in the margin.

# 1.0 INSTALLATION OVERVIEW

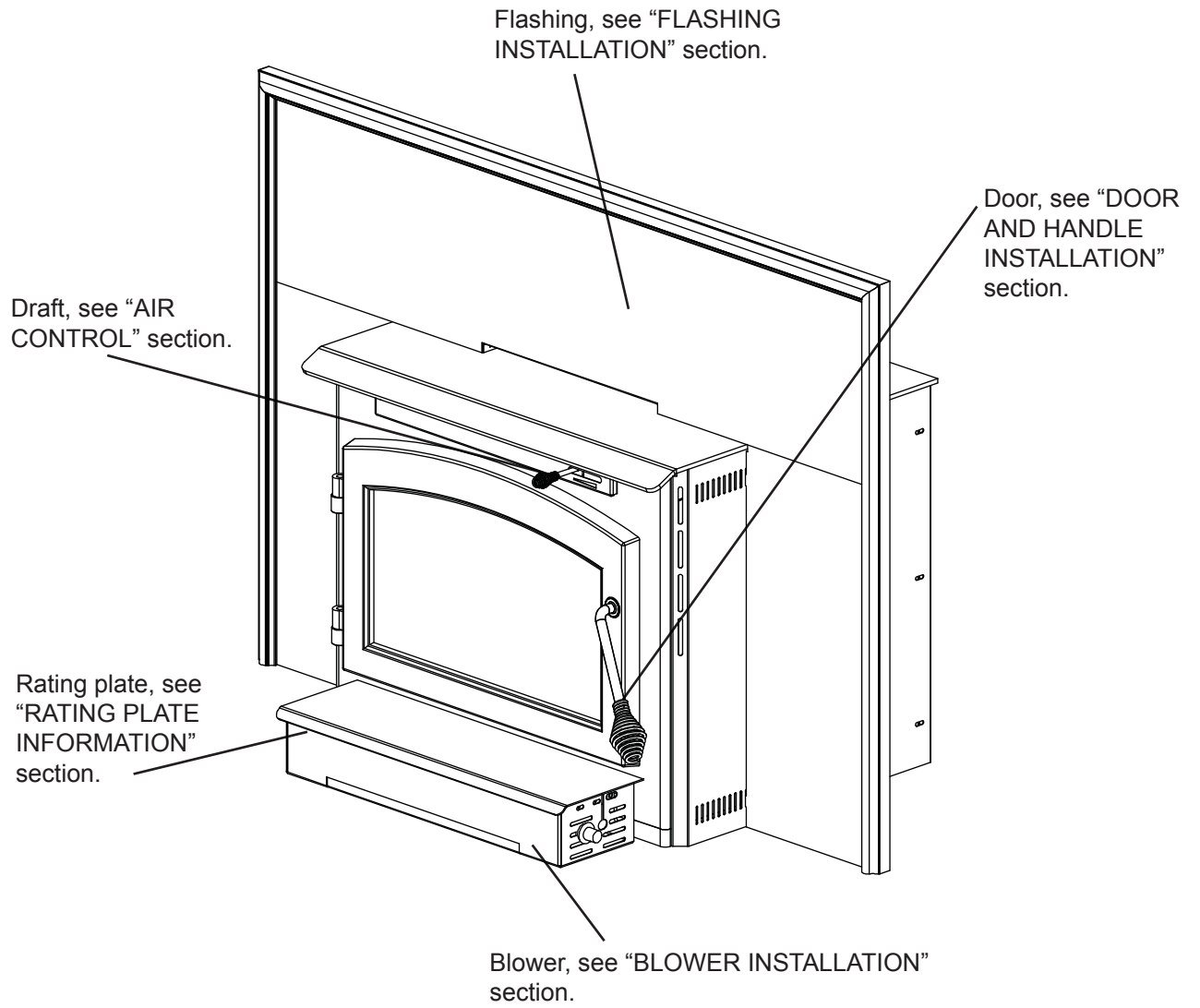

## 2.0 INTRODUCTION

### WARNING

- **THIS APPLIANCE IS HOT WHEN OPERATED AND CAN CAUSE SEVERE BURNS IF CONTACTED.**
- Do not operate appliance before reading and understanding operating instructions. Failure to operate appliance according to operating instructions could cause fire or injury.
- Before installing this appliance, contact the local building or fire authority and follow their guidelines.
- This appliance must be installed by a qualified installer.
- Risk of burns. The appliance should be turned off and cooled before servicing.
- Do not let the appliance become hot enough for any part to glow red.
- Do not install damaged, incomplete or substitute components.
- Risk of cuts and abrasions. Wear protective gloves and safety glasses during installation. Sheet metal edges may be sharp.
- Young children should be carefully supervised when they are in the same room as the appliance. Toddlers, young children and others may be susceptible to accidental contact burns. A physical barrier is recommended if there are at risk individuals in the house. To restrict access to an appliance or stove, install an adjustable safety gate to keep toddlers, young children and other at risk individuals out of the room and away from hot surfaces.
- Clothing or other flammable material should not be placed on or near the appliance. Objects placed in front of the appliance must be kept a minimum of 48" away from the front face of the appliance.
- Due to high temperatures, the appliance should be located out of traffic and away from furniture and draperies.
- Ensure you have incorporated adequate safety measure to protect infants/toddlers from touching hot surfaces.
- Even after the appliance is out, the glass and/or screen will remain hot for an extended period of time.
- Check with your local hearth specialty dealer for safety screens and hearth guards to protect children from hot surfaces. These screens and guards must be fastened to the floor.
- Any safety screen or guard removed for servicing must be replaced prior to operating the appliance.
- Under no circumstances should this appliance be modified.
- Do not operate the appliance with the glass door removed, cracked or broken. Replacement of the glass should be done by a licensed or qualified service person.
- Do not strike or slam shut the appliance glass door.
- Operate only with the doors tightly closed.
- Only doors / optional fronts certified with the unit are to be installed on the appliance.
- Keep the packaging material out of reach of children and dispose of the material in a safe manner. As with all plastic bags, these are not toys and should be kept away from children and infants.
- If the appliance is not properly installed, a house fire may result. Do not expose the appliance to the elements (ex. rain, etc.) and keep the appliance dry at all times. Wet insulation will produce an odour when the appliance is used.
- The chimney must be sound and free of cracks. Clean your chimney a minimum of twice a year and as required.
- Do not start a fire with chemicals or fluids such as gasoline, engine oil, etc.
- Your appliance requires periodic maintenance and cleaning. Failure to maintain your appliance may lead to smoke spillage in your home.
- Higher efficiencies and lower emissions generally result when burning air dried seasoned hardwoods, as compared to softwoods or too green or freshly cut hardwoods. Burning wet unseasoned wood can cause excessive creosote accumulation. When this is ignited it can cause a chimney fire that may result in a serious house fire.
- This appliance is designed to burn natural wood only. Do not burn treated wood, coal, charcoal, coloured paper, cardboard, solvents or garbage.
- Burn wood behind the log retainer directly on the firebricks. Do not elevate grate or otherwise raise the fire.
- Do not store wood within appliance installation clearances or within the space required for re-fueling and ash removal.

3.17A

## 2.1 DIMENSIONS (COMPLETE WITH FLASHING)

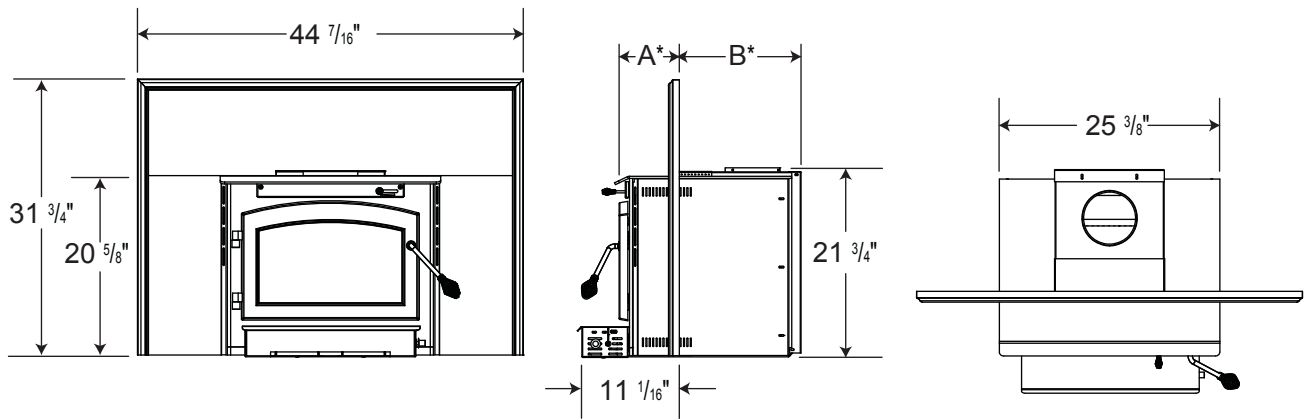

\* A and B are adjustable in 1/4" increments (see min max below).

## 2.2 SPECIFICATIONS

Specifications	2201	
CHAMBER (D.W.H)	14 5/8" x 20 7/8" x 11 5/8"	
CAPACITY	1.9 ft <sup>3</sup>	
APPROX. AREA HEATED*	800-1800 ft <sup>2</sup>	
HEAT OUTPUT (HIGH BURN) **	60,000 BTU	
DURATION LOW FIRE*	8 Hours	
WEIGHT w/o BRICKS	225 lbs	
WEIGHT OF BRICKS	60 lbs	
	A	B
MIN DEPTH	7 1/2"	14"
MAX DEPTH	4"	17 1/2"

\* Figures will vary considerably with individual conditions.

\*\* Wolf Steel Ltd. estimated realistic BTU/h with hardwood logs and regular refueling.

## 2.3 GENERAL INSTRUCTIONS

### ! WARNING

ALL WIRING SHOULD BE DONE BY A QUALIFIED ELECTRICIAN AND SHALL BE IN COMPLIANCE WITH LOCAL CODES. IN THE ABSENCE OF LOCAL CODES, USE THE CURRENT CSA22.1 CANADIAN ELECTRIC CODE IN CANADA OR THE CURRENT NATIONAL ELECTRIC CODE ANSI/NFPA NO. 70 IN THE UNITED STATES.

THIS APPLIANCE HAS NOT BEEN TESTED WITH ANY VENTED OR UNVENTED GAS LOG SET. TO REDUCE RISK OF FIRE OR PREVENT INJURY, DO NOT INSTALL A VENTED OR UNVENTED GAS LOG SET INTO THE APPLIANCE.

BURNING YOUR UNIT WITH THE ASH DUMP DOOR OPEN OR AJAR CREATES A FIRE HAZARD THAT MAY RESULT IN DISCOLOURATION TO THE GOLD PLATED DOOR, INTERNAL DAMAGE TO THE APPLIANCE OR A HOUSE CHIMNEY FIRE.

DO NOT CONNECT THIS APPLIANCE TO A CHIMNEY FLUE SERVING ANOTHER APPLIANCE.

THIS APPLIANCE AND IT'S COMPONENTS ARE DESIGNED TO BE INSTALLED AND OPERATED AS A SYSTEM. ANY ALTERATION TO OR SUBSTITUTION FOR ITEMS IN THIS SYSTEM, UNLESS ALLOWED BY THESE INSTALLATION INSTRUCTIONS, WILL VOID THE LISTING AND MAY VOID THE PRODUCT WARRANTY. IT MAY ALSO CREATE A HAZARDOUS INSTALLATION. READ THROUGH THESE INSTRUCTIONS THOROUGHLY BEFORE STARTING YOUR INSTALLATION AND FOLLOW THEM CAREFULLY THROUGHOUT YOUR PROJECT.

- Before beginning your installation, consult with your local building code agency or fire officials and insurance representative to ensure compliance.
- Non-toxic smoke will be emitted during the paint curing process, to help dissipate the smoke open a window near the appliance.
- Remove any dust or debris off the top of the appliance before firing the appliance as the paint will become soft as the appliance heats up and will harden as the appliance cures. To cure the paint on your appliance burn your appliance moderately hot during the first few fires.
- To keep the gasket from sticking to the appliance as the paint is curing, periodically open the door every 5-10 minutes.
- For the first two weeks use generous amounts of fuel and burn the appliance with the damper wide open for an hour as the appliance goes through a process of eliminating moisture in the steel and firebricks. The initial heat output will be reduced while the moisture is being drawn from the appliance and it will be necessary to build several hot fires to remove this moisture. **DURING THIS PROCESS DO NOT OVERFIRE THE APPLIANCE. REDUCE THE AMOUNT OF AIR COMING INTO THE APPLIANCE IF THE APPLIANCE OR CHIMNEY BECOMES RED.**

## 2.4 GENERAL INFORMATION

Your appliance was specifically designed to meet the 1990 U.S.A. EPA particulate emission standards and have been extensively tested in Canadian and American laboratories. This system is the most efficient, simple and trouble free we know and works as follows:

Your appliance is the exact duplication of the clean-burning technology found in all Timberwolf® EPA certified free-standing stoves. External modifications have been made to allow its installation as a “functional insert” with a heat circulating blower system and a means of enclosing the solid fuel burning fireplace cavity for greater heating efficiency.

Your appliance must be installed only into a solid fuel burning fireplace that is at least 14” deep 25 7/8” wide and 22” high with an approved lined chimney at least 15 feet high (4.6m) and a hearth of 18”. This minimum recess can only be achieved if the opening height is sufficient enough to allow the connector to fit under the noncombustible facing. The appliance and chimney must be constructed in accordance with all national and local building code standards.

The chimney vent system used on your wood burning appliance should be designed with the least amount of restriction possible to enable the exhaust products to easily flow through it. Chimney vent systems that are too short or too long can also have an adverse affect on the flow of exhaust through it. The wood burning appliance and chimney vent system also require a sufficient supply of combustion air not only to support the combustion in the combustion chamber but to replace the exhaust leaving it so it can flow freely up through the vent system and out into the atmosphere. It is the correct balance of combustion air and the chimney vent system that will ensure the appliance provides you with its optimum performance.

Secondary air from the rear intake opening travels up the back in the secondary air housing to the manifold located across the top and flows out laterally to oxidize the gases below the smoke exit.

The lower combustion chamber is lined with high temperature firebricks on 2 sides, the back and across the bottom, with a layer of fibre baffles at the top to maintain a high temperature in the combustion chamber so that gases mixing with the preheated air from the secondary air manifold tube are easily ignited and burned. The appliance sides and back are shielded to direct the heat upwards and forwards into the room.

Be sure to provide sufficient combustion air. There are many other appliances in your home competing for air such as: a kitchen range hood, forced air heating devices or a bathroom exhaust fan.

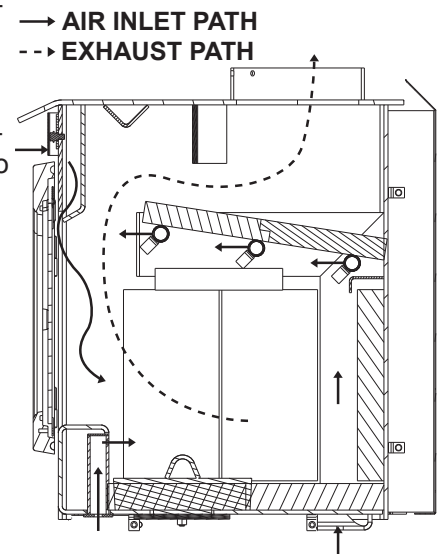

Expansion / contraction noises during heating up and cooling down cycles are normal and to be expected.

After extended periods of non-operation such as following a vacation or a warm weather season, the appliance may emit a slight odour for a few hours. This is caused by dust particles on the firebox burning off. Open a window to sufficiently ventilate the room.

**CALIFORNIA PROP 65 WARNING:**

Use of this product may produce smoke which contains chemicals known to the State of California to cause cancer, birth defects, or other reproductive harm.

If you experience smoking problems, you may need to open a door, a window or otherwise provide some method of supplying combustion air to the appliance.

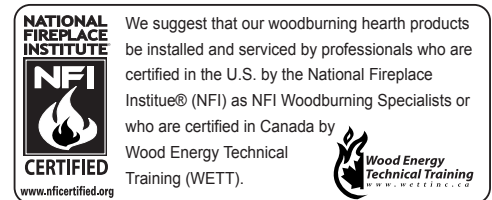

## 2.5 RATING PLATE LOCATION

For rating plate location, see "INSTALLATION OVERVIEW" section.



Tested & Listed By  
OTL US  
Portland Oregon USA  
OMNI Test Laboratories, Inc.  
REPORT NO. 415-S-08-2

**LISTED SOLID FUEL BURNING FIREPLACE INSERT**  
**ENCASTRÉ À COMBUSTIBLE SOLIDE HOMOLOGUÉ**  
**TESTED TO: / TESTÉ SELON:**  
**UL1482 / ULC S628**  
**MODEL / MODÈLE: 2201**

INSTALL AND USE ONLY IN ACCORDANCE WITH THE MANUFACTURER'S INSTRUCTIONS AND LOCAL BUILDING CODES.  
**MINIMUM CEILING HEIGHT:** 7FT (2.13m)  
**HEARTH EXTENSION / FLOOR PROTECTION:** MUST BE NON-COMBUSTIBLE AND EXTEND 22" IN FRONT OF THE INSERT AND 8" ON BOTH SIDES WITH A MINIMUM THICKNESS OF .500" (K=0.84)  
**CHIMNEY TYPE:** MINIMUM 6" (152mm) DIAMETER APPROVED RESIDENTIAL TYPE FOR MOBILE HOME USE A CHIMNEY LISTED TO ULC S629 IN CANADA OR UL 103HT IN THE USA.  
**CHIMNEY CONNECTOR:** 6" (152mm) DIAMETER MINIMUM 24 GAUGE STEEL. MINIMUM CLEARANCE FROM HORIZONTAL CONNECTOR AND CEILING 18" (457mm).  
DO NOT OBSTRUCT SPACE UNDER HEATER.  
SPECIAL METHODS ARE REQUIRED WHEN PASSING A CHIMNEY THROUGH A WALL OR CEILING. SEE INSTRUCTIONS AND BUILDING CODES.  
DO NOT CONNECT THIS UNIT TO A CHIMNEY FLUE SERVING ANOTHER APPLIANCE.  
**FUEL:** FOR USE WITH SOLID WOOD FUEL ONLY. DO NOT USE GRATE OR ELEVATE FIRE. BUILD WOOD FIRE DIRECTLY ON HEARTH.  
**WARNING:** RISK OF SMOKE SPILLAGE. OPERATE ONLY WITH DOOR FULLY CLOSED.  
REPLACE GLASS ONLY WITH CERAMIC GLASS.  
DO NOT OVERFIRE. IF HEATER OR CHIMNEY CONNECTORS GLOW, YOU ARE OVERFIRING. INSPECT AND CLEAN CHIMNEY FREQUENTLY. UNDER CERTAIN CONDITIONS OF USE CREOSOTE BUILD-UP MAY OCCUR RAPIDLY.  
**OPTIONAL BLOWER KIT:** EP-62, 115V, 60HZ, 0.82AMP. ROUTE CORD AWAY FROM UNIT.  
**DANGER:** RISK OF ELECTRICAL SHOCK. DISCONNECT POWER BEFORE SERVICING UNIT.  
**INSERT:** INSTALL AND USE ONLY IN SOLID FUEL BURNING FIREPLACES. DO NOT REMOVE BRICKS OR MORTAR FROM SOLID FUEL BURNING FIREPLACE. INSTALL WITH A POSITIVE FLUE CONNECTOR AND FACEPLATE.

CONTACT LOCAL BUILDING FIRE OFFICIALS ABOUT RESTRICTIONS AND INSTALLATION INSPECTION IN YOUR AREA.

A MINIMUM CLEARANCE OF 18" (457mm) TO THE CHIMNEY CONNECTOR MAY BE REQUIRED BY THE AUTHORITY HAVING JURISDICTION.

POUR INSTALLATION ET UTILISATION CONFORMÉMENT AUX INSTRUCTIONS DU FABRICANT ET AUX CODES LOCAUX DU BÂTIMENT.  
**HAUTEUR DE PLAFOND MINIMAL:** 7PI (2.13m)  
**BASE DE PROTECTION/PROTECTION DE PLANCHER:** DOIT ÊTRE DE NATURE INCOMBUSTIBLE ET SE PROLONGER DE 22" À L'AVANT DE L'ENCASTRÉ ET 8" SUR LES CÔTÉS, ET AVOIR UNE ÉPAISSEUR MINIMALE DE 0.500" (K = 0,84).  
**TYPE DE CHIMNÉE:** DIAMÈTRE MINIMAL DE 6" (152mm) APPROUVÉE POUR USAGE RÉSIDENTIEL. MAISON MOBILE EMPLOYEZ UNE CHEMINÉE HOMOLOGUÉE ULC S629 AU CANADA OU UL 103HT AUX ÉTATS-UNIS.  
**RACCORD DE CHEMINÉE:** DIAMÈTRE DE 6" (152mm) D'ACIER DE CALIBRE 24 MINIMUM. 18" (457mm) DE DÉGAGEMENT MINIMAL ENTRE LE RACCORD HORIZONTAL ET LE PLAFOND.  
NE RIEN ENTREPOSER SOUS L'APPAREIL.  
DES MÉTHODES SPÉCIALES SONT REQUISES LORSQU'UNE CHEMINÉE TRAVERSE UN MUR OU UN PLAFOND. VOIR LES INSTRUCTIONS ET LES CODES DU BÂTIMENT.  
NE PAS RACCORDER À LA CHEMINÉE D'UN AUTRE APPAREIL.  
**COMBUSTIBLE:** POUR USAGE AVEC LE BOIS SEULEMENT. N'UTILISEZ PAS DE CHENET OU NE SURÉLEVEZ PAS LE BOIS. PRÉPAREZ LE FEU DIRECTEMENT SUR L'ÂTRE.  
**AVERTISSEMENT:** RISQUE D'ÉCHAPPEMENT DE FUMÉE. TENIR LA PORTE FERMÉE LORSQUE LE POÊLE FONCTIONNE. REMPLACEZ LA VITRE PAR UNE VITRE EN CÉRAMIQUE SEULEMENT.  
NE SURCHAUFFEZ PAS L'APPAREIL. SI L'APPAREIL OU LES RACCORDS ROUGEOTENT, L'APPAREIL SURCHAUFFE. INSPECTEZ ET NETTOYEZ LA CHEMINÉE FRÉQUEMMENT. DANS CERTAINES CONDITIONS, DES DÉPÔTS DE CRÉOSOTE PEUVENT SE FORMER RAPIDEMENT.  
**SOUFFLERIE OPTIONNELLE:** EP-62, 115V, 60HZ, 0.82A. TENEZ LE CORDON ÉLECTRIQUE LOIN DE L'APPAREIL.  
**DANGER:** RISQUE DE SECOURS ÉLECTRIQUE. DÉBRANCHEZ AVANT DE PROCÉDER À L'ENTRETIEN.  
**ENCASTRÉ:** INSTALLEZ ET UTILISEZ SEULEMENT DANS UN FOYER À COMBUSTIBLE SOLIDE. NE RETIREZ PAS DE MORTIER, NI BRIQUES DU FOYER À COMBUSTIBLE SOLIDE.  
INSTALLEZ AVEC UNE GAINÉ CONFORME ET UNE PLAQUE DE RECouvreMENT.  
  
RENSEIGNEZ-VOUS AUPRÈS DES AUTORITÉS LOCALES DU BÂTIMENT ET DU SERVICE DES INCENDIES AU SUJET DES RESTRICTIONS ET DES INSPECTIONS D'INSTALLATION DANS VOTRE RÉGION.  
  
UN DÉGAGEMENT MINIMAL DE 18" (457mm) JUSQU'AU RACCORD DE LA CHEMINÉE PEUT ÊTRE EXIGÉ PAR L'AUTORITÉ AYANT JURISDICTION.

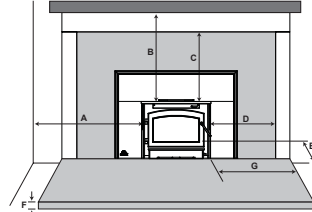

**CLEARANCE TO COMBUSTIBLE CONSTRUCTION / DÉGAGEMENTS AUX MATÉRIEAUX COMBUSTIBLES:**  
(MEASURED TO UNIT / À PARTIR DE L'APPAREIL)

UNIT / APPAREIL	ADJACENT SIDE WALL (TO SIDE) / MUR LATÉRAL ADJACENT (AU CÔTÉ) A	MANTLE (TO TOP) / MANTEAU (JUSQU'AU DESSUS) B	TOP FACING (TO TOP) / HAUT DE LA FAÇADE (JUSQU'AU DESSUS) C	SIDE FACING (TO SIDE) / CÔTÉ DE LA FAÇADE (AU CÔTÉ) D	MINIMUM HEARTH EXTENSION / BASE DE PROTECTION MINIMALE E	MINIMUM HEARTH THICKNESS / ÉPAISSEUR MINIMALE DE LA BASE DE PROTECTION F	MINIMUM HEARTH SIDE EXTENSION / BADE DE PROTECTION LATÉRALE MINIMALE G
2201	16"	30"	22"	10"	18"	1"	8"



**CAUTION:** HOT WHILE IN OPERATION. DO NOT TOUCH. KEEP CHILDREN CLOTHING AND FURNITURE AWAY. CONTACT MAY CAUSE SKIN BURNS.

**ATTENTION:** QUAND L'APPAREIL FONCTIONNE, LA SURFACE DEVIENT CHAUDE. NE PAS TOUCHER. TENIR LES ENFANTS, LES VÊTEMENTS ET LES MEUBLES À L'ÉCART. LE CONTACT PEUT CAUSER DES BRÛLURES À LA PEAU.

MADE IN / FABRIQUÉ AU:  
**WOLF STEEL LTD.**  
**BARRIE, ONTARIO CANADA** ■  
24 NAPOLEON ROAD,  
BARRIE, ON, L4M 4Y8 CANADA  
**NAC GUANGZHOU P.R.C.** ■  
NO.69 HEFENG ROAD,  
GUANGZHOU, CHINA

U.S. ENVIRONMENTAL PROTECTION AGENCY Certifié conforme à la norme d'émanation de particules de juillet 1992.

**TI-2201** DATE CODE / DE DATE

W385-0504

## 3.0 INSTALLATION PLANNING

Clean all ashes out of the inside of the existing fireplace opening. Make sure that the chimney and fireplace are free of cracks, loose mortar, creosote deposits, blockage or other signs of deterioration. If necessary, have any repair work done by a qualified professional before installing the insert.

Do **NOT** remove bricks or mortar from the fireplace. In case of an outside air inlet or ash dump, fill with fiber-glass insulation. Adhere to minimum clearances as illustrated.

Combustible material must not protrude more than 1" to the side of the insert or between the mantel and the top of the insert.

### 3.1 MINIMUM CLEARANCE TO COMBUSTIBLES

MINIMUM CLEARANCES		
A	Sidewall	16"
B	Mantel	30"
C	Top facing	22"
D	Side facing	10"
E	Hearth (front)	22"
F	Hearth (side)	8"
G	In front of insert	48"
MINIMUM APPLIANCE SIZE		
H	Width (rear)	25 7/8"
I	Width (front)	25 7/8"
J	Height (front)	22"
K	Height (rear)	22"
L	Depth	14"
M	Hearth depth	18"
N	Hearth width	41 7/8"
O	Facing width	45 7/8"
P	Facing height	47 7/8"
Q	Mantel	52 5/8"

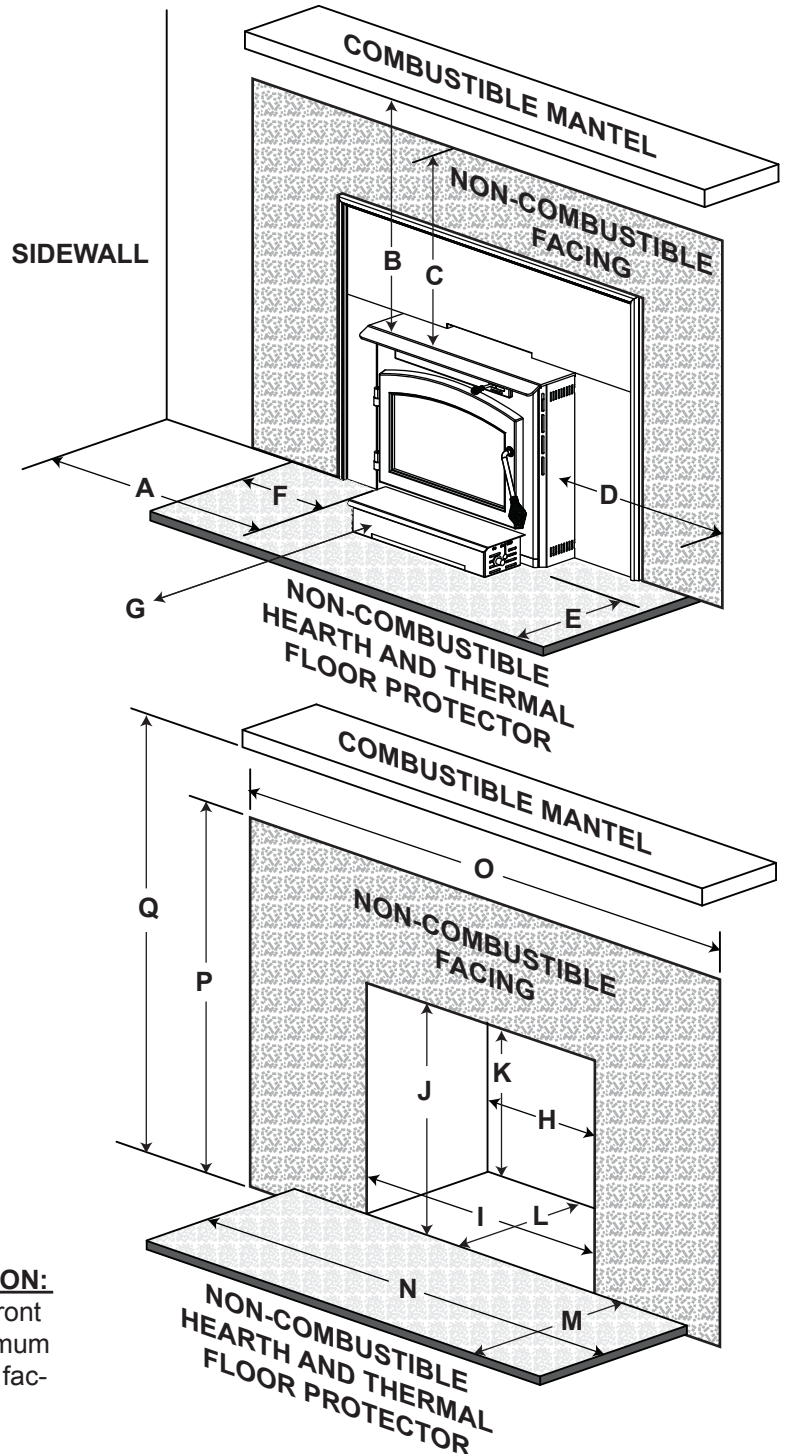

#### **HEARTH EXTENSION / FLOOR PROTECTION:**

Must be non-combustible and extend 22" in front of the insert and 8" on both sides with a minimum thickness of .500" and a thermal conductivity factor (K) 0.84.

## 4.0 INSTALLATION

 <b>WARNING</b>
<b>WEAR GLOVES AND SAFETY GLASSES FOR PROTECTION.</b>
<b>CAREFULLY FOLLOW THE INSTRUCTIONS FOR ASSEMBLY OF THE PIPE AND OTHER PARTS NEEDED TO INSTALL THE APPLIANCE. FAILURE TO DO SO MAY RESULT IN A FIRE, ESPECIALLY IF COMBUSTIBLES ARE TOO CLOSE TO THE APPLIANCE OR CHIMNEY AND AIR SPACES ARE BLOCKED, PREVENTING THE FREE MOVEMENT OF COOLING AIR.</b>
<b>DO NOT DRAW OUTSIDE AIR FROM GARAGE SPACES. EXHAUST PRODUCTS OF GASOLINE ENGINES ARE HAZARDOUS.</b>
<b>DO NOT INSTALL OUTSIDE AIR DUCTS SUCH THAT THE AIR MAY BE DRAWN FROM ATTIC SPACES, BASEMENTS OR ABOVE THE ROOFING WHERE OTHER HEATING APPLIANCES OR FANS AND CHIMNEYS EXHAUST OR UTILIZE AIR. THESE PRECAUTIONS WILL REDUCE THE POSSIBILITY OF APPLIANCE SMOKING OR AIR FLOW REVERSAL. THE OUTSIDE AIR INLET MUST REMAIN CLEAR OF LEAVES, DEBRIS ICE AND/OR SNOW. IT MUST BE UNRESTRICTED WHILE APPLIANCE IS IN USE TO PREVENT ROOM AIR STARVATION WHICH CAN CAUSE SMOKE SPILLAGE AND AN INABILITY TO MAINTAIN A FIRE. SMOKE SPILLAGE CAN ALSO SET OFF SMOKE ALARMS.</b>
<b>NEGATIVE PRESSURE WITHIN YOUR HOME MAY INADVERTENTLY AFFECT YOUR APPLIANCE.</b>
<b>TO PREVENT CONTACT WITH SAGGING OR LOOSE INSULATION, THE APPLIANCE MUST NOT BE INSTALLED AGAINST VAPOUR BARRIERS OR EXPOSED INSULATION. LOCALIZED OVERHEATING COULD OCCUR AND A FIRE COULD RESULT.</b>
<b>DO NOT USE MAKESHIFT COMPROMISES DURING INSTALLATION. DO NOT BLOCK OR RESTRICT AIR, GRILLE OR LOUVRE OPENINGS. DO NOT ADD A HOOD.</b>

68.3

It is extremely important that your appliance be installed according to the manufacturer's specifications. The manufacturer's installation instructions and specified clearances should always be followed in accordance with local and national codes. In Canada the CSA B365 and the CSA C22.1 installation codes are to be followed. In the USA the ANSI NFPA 70 and ANSI NFPA 211 installation codes are to be followed.

Chimney and liner must be in good condition and kept clean.

## 4.1 TYPICAL EXISTING MASONRY

You can install your appliance using your existing masonry chimney. To do so, follow the guidelines below. If you are using a masonry chimney, it is important that it be built in compliance with the specifications of the Building Code in your region. It must normally be lined with fire clay bricks, metal or clay tiles sealed together with fire cement. (Round flues are the most efficient).

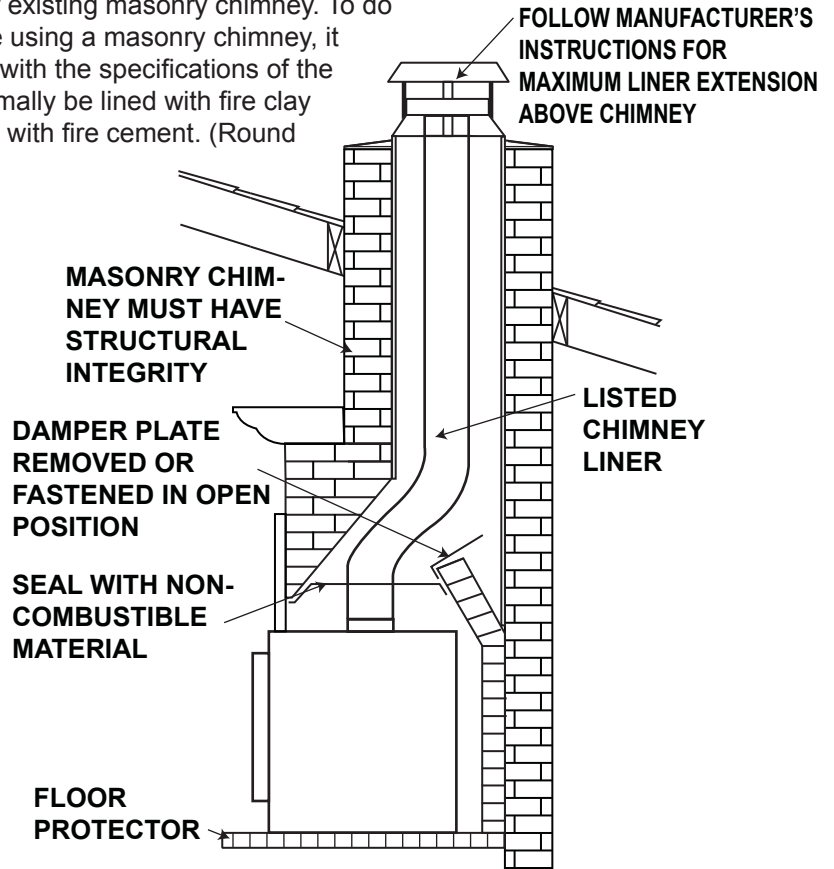

- A. Remove the fireplace damper or fasten it permanently open.  
 \* We recommend the following method of sealing off the damper area around the liner.
- B. \* Measure the throat of the fireplace and mark this shape on a piece of 24 gauge sheet metal (flue cover); cut a six-inch (6.75") hole to lie directly below the fireplace flue opening. Allow two inches of material for a flange on all sides and cut to these measurements. Bend down the flanges. If you have never done this before, it might be a good idea to make a cardboard pattern and test it first. Fasten this flue cover in position as high as possible with two masonry screws per side through the flanges into the fireplace.

**In Canada:** Install a listed 6 inch diameter flexible stainless steel liner from the top of the chimney to the insert flue collar. Attach a stainless steel liner connector or elbow to the liner and insert onto the flue collar. Fasten with three screws. Secure the top of the liner to the chimney cap using a liner support and chimney flashing. Cap the top of the chimney liner assembly using an approved rain cap.

**In the United States:** While it is not required, it is recommended that a chimney liner be installed that is continuous from the insert to the top of the chimney, particularly when the insert is installed in a basement. For this type of connection, use the "In Canada" installation instructions above. If a continuous liner is not installed, a "direct flue connection" must be made. The direct flue connection requires a non-combustible connector that extends from the insert into the chimney flue liner and also that the installed flue cover be sealed below the entry point of the connector to prevent dilution of combustion products in the chimney flue with air from inside the house. Cap the top of the chimney using an approved rain cap.

The following installation requirements must be observed when installing solid fuel burning inserts into factory built fireplaces.

## 4.2 FACTORY BUILT FIREPLACE

- A. The factory built fireplace must be listed per UL 127 or ULC S610.
- B. Clearances to any combustible material surrounding this insert as identified must be followed. These clearance requirements supersede any pre-existing facing material clearances listed for the factory built fireplace.
- C. Installation must include a full height listed chimney liner meeting HT requirements (2100°F) as required in UL 1777 (U.S.) or ULC S635 (Canada). The liner must be securely attached to the insert flue collar and the chimney top.
- D. Means must be provided to prevent room air passage to the chimney cavity of the fireplace. This may be accomplished by sealing the damper area around the chimney liner, or sealing the appliance front.
- E. The air flow within and around the appliance shall not be altered by the installation of the insert (i.e. no louvres or cooling air inlet or outlet ports are blocked), unless specifically tested as such for each factory built fireplace manufacturer and model line. **NOTE: Using a louvered face plate (surround) complies with this requirement.**
- F. Alteration of the appliance in any manner is not permitted with the following exceptions;
  - A. External trim pieces which do not affect the operation of the appliance may be removed providing they can be stored on or within the fireplace for reassembly if the insert is removed.
  - B. The chimney damper may be removed to install the chimney liner.
- G. Circulating air chambers (i.e. in a steel fireplace liner or metal heat circulator) shall not be blocked.
- H. Means must be provided for removal of the insert to clean the chimney flue.
- I. Inserts that project in front of the fireplace must be supplied with appropriate support means.
- J. A permanent metal warning label must be attached to the back of the fireplace stating that the fireplace must be restored to its original condition for safe use without the insert.

## 5.0 FINISHING

### 5.1 SECONDARY AIR TUBES

**5.1.1** Start at the back working forwards, install the secondary air tube by inserting the tube into the hole, as illustrated in "A".

**5.1.2** Slide the tube into the opposite hole. With the holes on the secondary air tube pointing forward, align the tube with the tube retainer and insert the cotter pin, as illustrated in "B".

**5.1.3** Spread the cotter pin to retain.

**NOTE:** There are 4 secondary air tubes. One of the tubes has larger holes. This tube is to be located closest to the front of the appliance, as illustrated in "C".

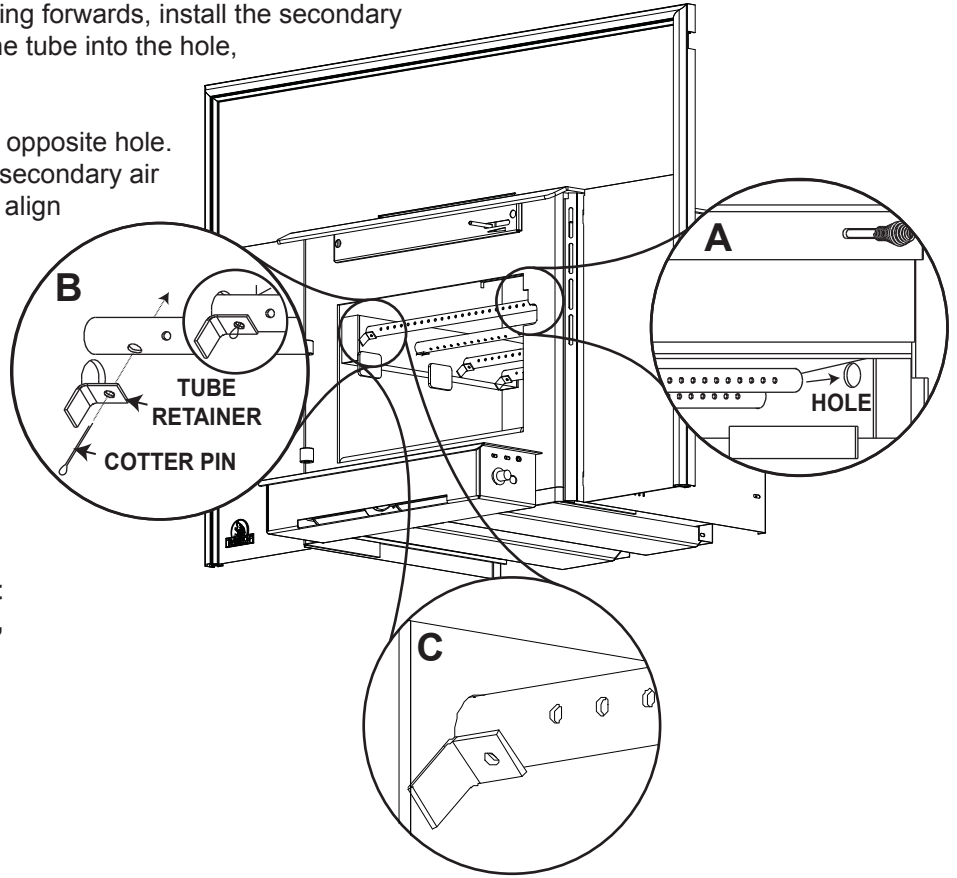

## 5.2 BRICKS AND BAFFLES INSTALLATION

### ! WARNING

OPERATION OF THE APPLIANCE WITHOUT THE BAFFLES CAN RESULT IN EXCESSIVE TEMPERATURES THAT COULD DAMAGE THE APPLIANCE, CHIMNEY AND THE SURROUNDING ENCLOSURE.

With the appliance and chimney installation completed, move the bricks into place as illustrated below.

- 5.2.1 Install the bottom nine (A) bricks and one (B) brick, working from the back of the appliance forward as illustrated.
- 5.2.2 Install four (A) bricks along both sides of the appliance.
- 5.2.3 Install the four (A) bricks and one (C) brick along the back wall by pivoting the bricks up under the brick retainer. **NOTE: Place narrow (C) brick in centre.**
- 5.2.4 Install two (D) bricks along the front of the appliance below the ledge at the bottom of the door opening.
- 5.2.5 Carefully pivot two (E) fibre baffles up onto the secondary air tubes as illustrated. Ensure that the top baffles are pushed all the way to the rear of the firebox, leaving a minimum of a 1 inch gap along the front. This will allow the flue gases to escape the firebox. Ensure overlap joint is tight.

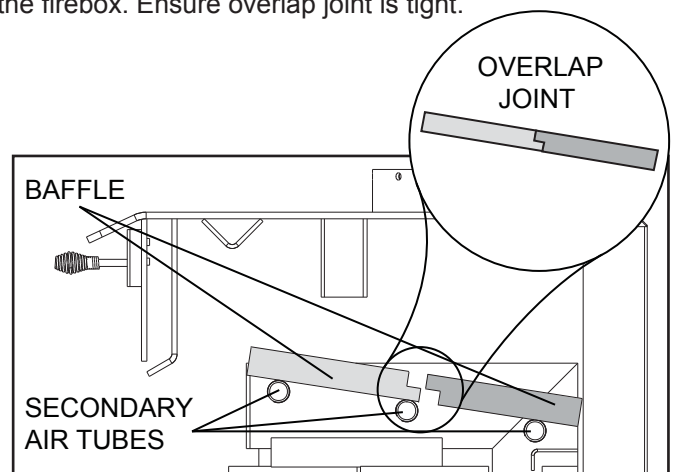
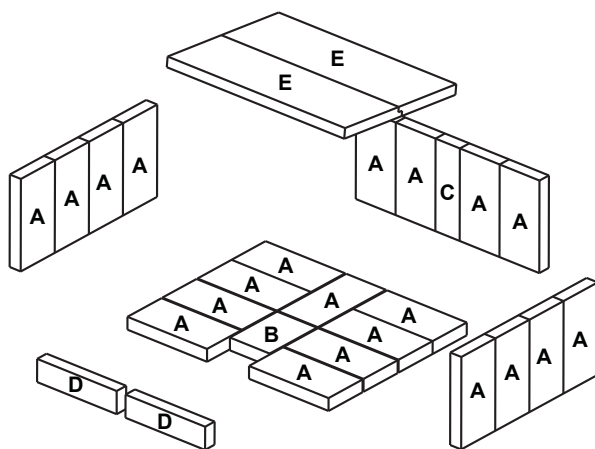

## 5.3 DOOR INSTALLATION

Hang the door using the hinge pins supplied.

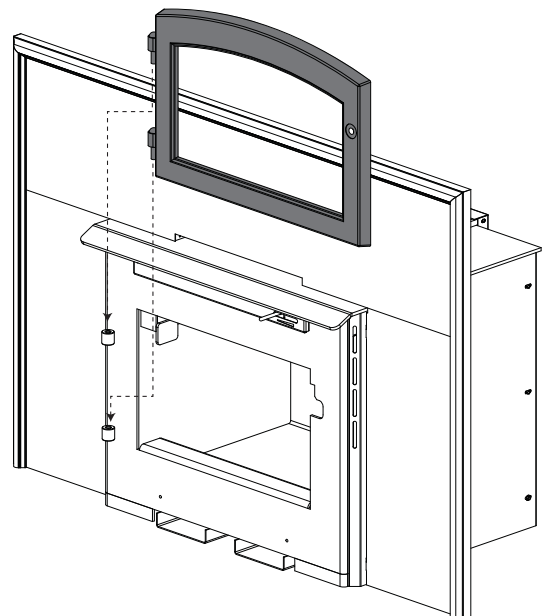

### 5.4 DOOR HANDLE INSTALLATION

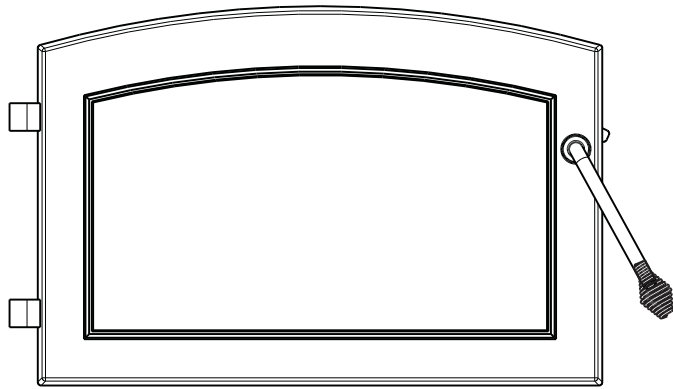

FRONT VIEW

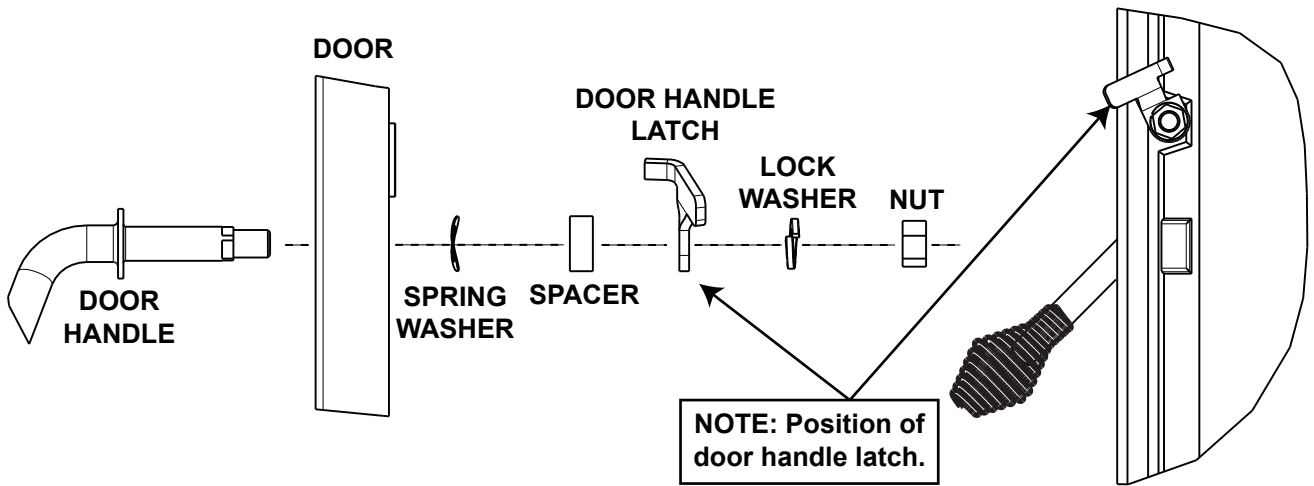

Twist the large wire handle over the end of the handle rod. Twist the smaller wire handle over the end of the air control rod above the door.

## 5.5 FLASHING INSTALLATION

The top and side flashings have been shipped flat.

- 5.5.1 To install the side flashings, engage the tabs into the slots which will position the insert in the preferred location.
- 5.5.2 Lower the top flashing against the appliance and secure using the clips as illustrated below.
- 5.5.3 Based on where the flashing has been installed, adjust the top chute tight against the top flashing and secure in place.
- 5.5.4 The three pieces of trim are assembled in the same manner as a picture frame. Place the corner brackets (with screw loosened) into the trim sections. Tighten the screw spreading the two pieces apart. Attach the adjoining section. Repeat with the opposite side. Tighten all screws firmly.
- 5.5.5 Slide the trim over the flashing.
- 5.5.6 Install the five spring clips provided by inserting them in between the trim and the back of the flashing as illustrated.

**NOTE:** The flashing on this appliance is adjustable in 1/4" increments. It has been designed to accommodate a minimum hearth depth of 14". Once the appliance has been installed, the flashing can be adjusted back to the facing material. If desirable the appliance can be moved back into the masonry opening as far as 17 1/2".

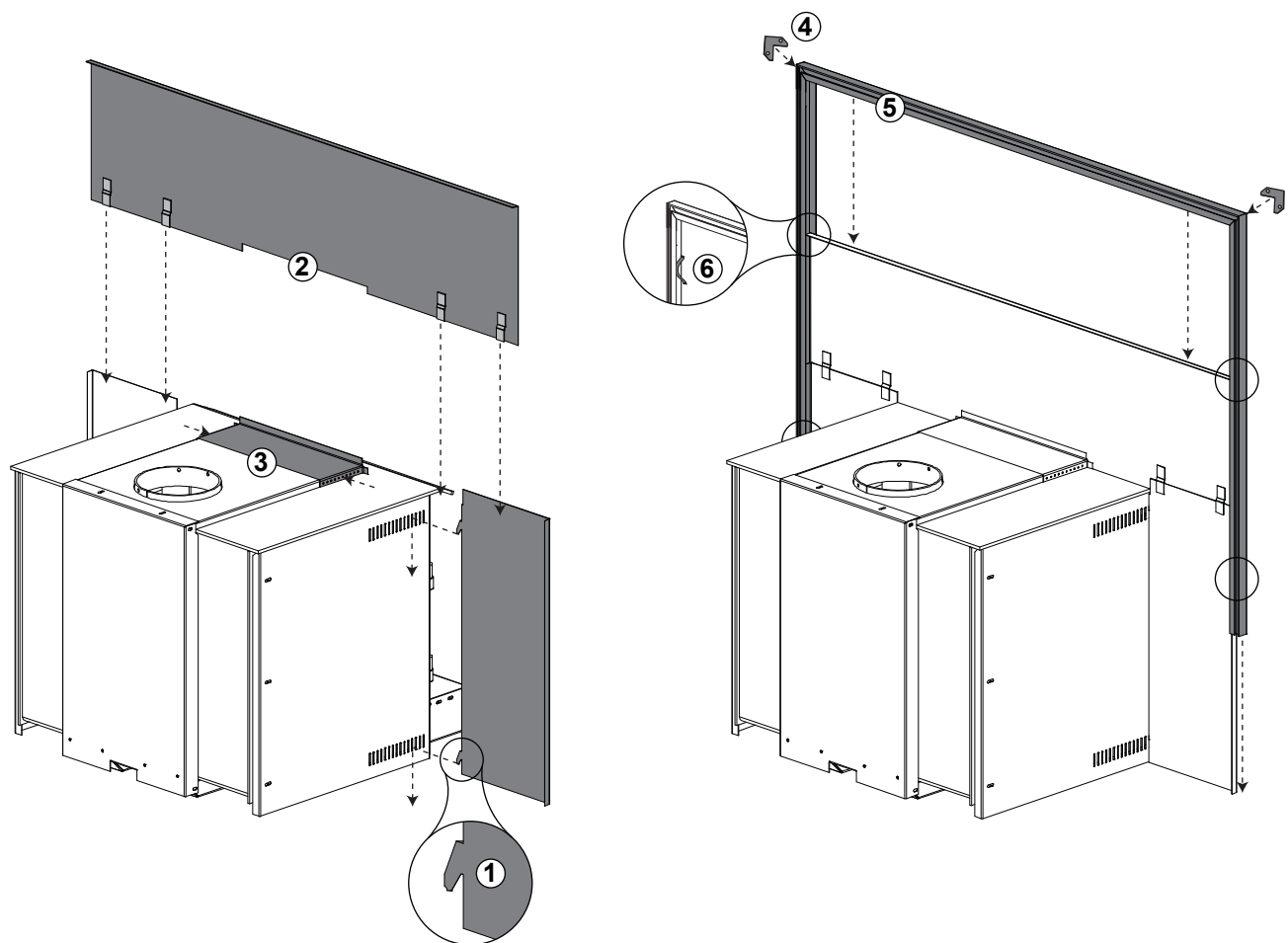

## 5.6 BLOWER INSTALLATION

### ! WARNING

RISK OF FIRE AND ELECTRICAL SHOCK.

TURN OFF THE ELECTRICAL POWER BEFORE SERVICING THIS APPLIANCE.

USE ONLY WOLF STEEL APPROVED OPTIONAL ACCESSORIES AND REPLACEMENT PARTS WITH THIS APPLIANCE. USING NON-LISTED ACCESSORIES (BLOWERS, DOORS, LOUVRES, TRIMS, ETC.) COULD RESULT IN A SAFETY HAZARD AND WILL VOID THE WARRANTY AND CERTIFICATION.

ENSURE THAT THE BLOWER'S POWER CORD IS NOT IN CONTACT WITH ANY SURFACE OF THE APPLIANCE TO PREVENT ELECTRICAL SHOCK OR FIRE DAMAGE. DO NOT RUN THE POWER CORD BENEATH THE APPLIANCE.

Drywall dust will penetrate into the blower bearings, causing irreparable damage. Care must be taken to prevent drywall dust from coming into contact with the blower or its compartment. Any damage resulting from this condition is not covered by the warranty policy. Use of the blower increases the output of heat.

This blower is thermally activated. Depending on the intensity of the fire, the blower will start 15-30 minutes after lighting. The thermal switch for the appliance is affixed to an adjustable bracket, which should be positioned so it is in contact with the blower housing as illustrated.

For shipping purposes the blower housing has been stored within the firebox. We recommend removing the door prior to installing the blower.

- 5.6.1 Remove the two screws securing the cover and set aside.
- 5.6.2 Engage the clips onto the retainer bracket and secure using the screw supplied.
- 5.6.3 Reattach the cover with the two screws previously removed.

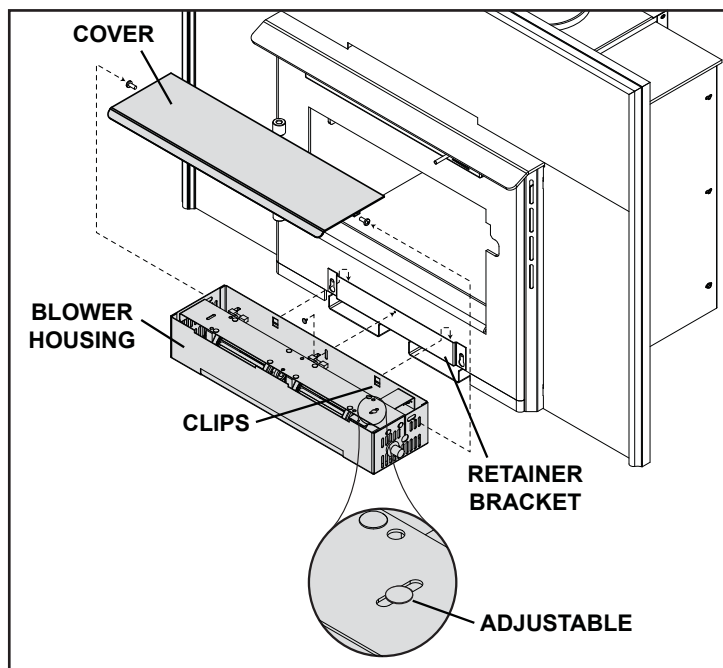

## 6.0 OPERATION

### WARNING

**ALWAYS OPERATE THIS APPLIANCE WITH THE DOOR CLOSED AND LATCHED EXCEPT DURING START UP AND RE-FUELING. ALWAYS WEAR GLOVES TO PREVENT INJURY. DO NOT LEAVE THE FIRE UNATTENDED WHEN THE DOOR IS UNLATCHED AS UNSTABLE WOOD COULD FALL OUT OF THE FIRE CHAMBER CREATING A FIRE HAZARD TO YOUR HOME.**

**NEVER LEAVE CHILDREN UNATTENDED WHEN THERE IS A FIRE BURNING IN THE APPLIANCE.**

**NEVER USE GASOLINE, GASOLINE-TYPE LANTERN FUEL, KEROSENE, CHARCOAL LIGHTER FLUID, OR SIMILAR LIQUIDS TO START OR 'FRESHEN UP' A FIRE IN THIS APPLIANCE. KEEP ALL SUCH LIQUIDS WELL AWAY FROM THE APPLIANCE WHILE IT IS IN USE.**

**OBJECTS PLACED IN FRONT OF THE APPLIANCE SHOULD BE KEPT A MINIMUM OF 48" FROM THE FRONT FACE.**

**ANY MODIFICATION OF THE APPLIANCE THAT HAS NOT BEEN APPROVED IN WRITING BY THE TESTING AUTHORITY IS CONSIDERED BREACHING CSA B365 (CANADA) AND ANSI NFPA 211 (USA).**

**OPEN AIR CONTROL (AND DAMPER WHEN FITTED) BEFORE OPENING FIRING DOOR.**

**HOT WHILE IN OPERATION, KEEP CHILDREN, CLOTHING AND FURNITURE AWAY. CONTACT MAY CAUSE SKIN BURNS. WEAR GLOVES TO OPERATE YOUR APPLIANCE.**

**BURNING YOUR APPLIANCE WITH THE DOORS OPEN OR AJAR CREATES A FIRE HAZARD THAT MAY RESULT IN A HOUSE AND OR CHIMNEY FIRE.**

Your Timberwolf EPA listed product is designed with the most advanced technology. The appliance is extremely air-tight.

The first fire(s) in your appliance will be difficult to get going and keep going with little amount of heat being generated. This is a result of the moisture being driven out of the fire brick. Allow 30 to 40 hours of hot fires (temperatures in excess of 500°F - 600°F) before your appliance will perform normally. During the break-in period (the first 2 or 3 fires) create only small, hot fires using kindling; this will allow the firebrick to cure. Do not be alarmed if small hairline cracks develop in the firebrick. This is a normal occurrence and does not pose a safety hazard. The paint may also smell a little for the first few fires as it cures and you may wish to open a door or window to alleviate the smell.

To start, a brisk fire is required. Place loosely crumpled paper on the floor of the appliance and cover with dry kindling. Open the air control fully by sliding control all the way to the right. Light the paper and leave the door slightly ajar (one inch) until all kindling is burning. To maintain a brisk fire, a hot coal bed must be established and sustained.

Slowly add larger wood (2x4 size pieces). Lay the pieces lengthwise from side to side in the hot coal bed with a shallow trench between, so that the primary air can flow directly into this trench and ignite the fuel above. When the fire seems to be at its peak, medium sized logs may be added. Once these logs have caught fire, carefully close the door. (Closing the door too quickly after refueling will reduce the firebox temperature and result in an unsatisfactory burn.) Remember it is more efficient to burn medium sized wood, briskly, and refuel frequently than to load the appliance with large logs that result in a smoldering, inefficient fire and dirty glass.

As soon as the door is closed, you will observe a change in the flame pattern. The flames will get smaller and lazier because less oxygen is getting into the combustion chamber. The flames, however, are more efficient. The flames will remain lazy but become larger again as soon as the firebricks have been heated thoroughly and the chimney becomes heated and provides a good draft. At this point, the roaring fire that you see when the door is opened is wastefully drawing heated room air up the chimney, certainly not desirable. Always operate with the door fully closed once the medium sized logs have caught fire.

You can now add larger pieces of wood and operate the appliance normally. Once the appliance is entirely hot, it will burn very efficiently with little smoke from the chimney. There will be a bed of orange coals in the firebox and secondary flames flickering just below the top baffles. You can safely fill the firebox with wood to the top of the door and will get best burns if you keep the appliance pipe temperatures between 250 degrees Fahrenheit (120 degrees Celsius) and 450 degrees Fahrenheit (270 degrees Celsius). A surface thermometer will help regulate this.

Without an appliance thermometer, you are working blindly and have no idea of how the appliance is operating! An appliance thermometer offers a guide to performance.

Can't get the fire going? Use more kindling and paper. Assuming the chimney and vent are sized correctly and there is sufficient combustion air, the lack of sufficiently dry quantities of small kindling is the problem. Thumb size is a good gauge for small kindling diameter.

Can't get heat out of the appliance? One of two things may have happened. The appliance door may have been closed prematurely and the appliance itself has not reached optimum temperature. Reopen the door and/or draft control to re-establish a brisk fire. The other problem may have been wet wood. The typical symptom is sizzling wood and moisture being driven from the wood.

## 6.1 AIR CONTROL

Draft is the force which moves air from the firebox up through the chimney. The amount of draft in your chimney depends on the length and diameter of chimney, local geography, nearby obstructions and other factors. Adjusting the air control all the way to the left reduces the temperature. The draft can be adjusted from low to high by moving the handle from left to right. Inadequate draft may cause back-puffing into the room through the appliance and chimney connector points and may cause plugging of the chimney. Too much draft may cause an excessive temperature in the appliance, glowing red appliance parts or chimney connectors or an uncontrollable burn which can lead to a chimney fire or permanent damage to the appliance. Do not operate your appliance for longer than 30 minutes with the air control on "HIGH" (fully open).

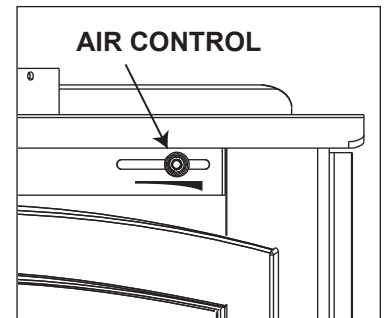

## 6.2 FIRE EXTINGUISHERS / SMOKE DETECTORS

All homes with a solid fuel burning appliance should have at least one fire extinguisher in a central location known to all and at least one smoke detector in the room containing the appliance. If it sounds an alarm, correct the cause but do not deactivate or relocate the smoke detector.

## 6.3 FUEL

### **! WARNING**

**DO NOT STORE FUEL WITHIN THE CLEARANCE TO COMBUSTIBLES, OR IN THE SPACE REQUIRED FOR RE-FUELING AND ASH REMOVAL.**

**BURNING WET, UNSEASONED WOOD CAN CAUSE EXCESSIVE CREOSOTE ACCUMULATION. WHEN IGNITED IT CAN CAUSE A CHIMNEY FIRE THAT MAY RESULT IN A SERIOUS HOUSE FIRE.**

When loading the appliance, ensure that the two upper fibre baffles are not lifted up and off their ledge. For maximum efficiency, when the appliance is thoroughly hot, load it fully to the top of the door opening and burn at a medium low setting. Maximum heat for minimum fuel (optimum burn) occurs when the appliance top temperature is between 500°F (260°C) and 600°F (315°C). The bricks will be nearly all white and the glass mostly clear. The whiteness of the bricks and the cleanliness of the glass are good indicators of your operating efficiency. Not enough heat is produced when only one or two pieces of wood are burned or the wood may not burn completely. A minimum of three pieces are needed to encase a bed of coals that sustains the fire.

**NOTE:** When loading the appliance, ensure to keep fuel back from the glass. If coals are to accumulate on the front lip, there is a chance they will fall out when the door is opened.

Loosely stacked wood burns quicker than a tightly packed load. Wood burns in cycles rather than giving a steady output of heat. It is best to plan these cycles around your household routine so that only enough coals are left to start the next load. In the evening, load your appliance, at least, a half-hour before bed to ensure a good fire, hot enough to close the draft control for an overnight burn.

Burn only dry seasoned wood. It produces more heat and less soot or creosote. Do not burn ocean beach wood. Its salt content can produce a metal eating acid. When refueling open the door slowly to prevent smoke spillage. Use a pair of long gloves (barbecue gloves) when feeding the fire. Because these appliances burn at the front, they are clean and efficient, but they are also very hot and gloves are useful. Keep a small steel shovel nearby to use as a poker and to remove ashes. Do not store the wood within 3 feet (1m) of the appliance.

## **6.4 LIGHTING A FIRE**

### **6.4.1 FLASH FIRE**

A flash fire is a small fire burned quickly when you don't need much heat. After your kindling has "caught", load at least 3 pieces of wood, stacked loosely. Burn with the draft control fully open or closed only slightly.

### **6.4.2 EXTENDED FIRE**

Load your larger pieces of wood compactly, packed close enough to prevent the flames from penetrating it completely.

After approximately 30 minutes, depending on the size of the load, close the draft control completely making sure that the fire is not extinguished.

#### **DO NOT OVERFIRE THE APPLIANCE!**

Overfiring can occur by:

- A. Burning large amounts of smaller wood pieces such as furniture scraps, skids or treated wood;
- B. Vigorously burning large loads of wood with the draft control on "HIGH" (fully open) for long periods of time (one or two hours).
- C. Leaking door gaskets that will permit excess air to enter the combustion chamber.

## **6.5 SMOKING**

A properly installed appliance should not smoke. If yours does, check the following:

- Has the chimney had time to get hot?
- Is the smoke passage blocked anywhere in the appliance, chimney connector or chimney?
- Is the room too airtight and the air intake not connected to the outside? Try with a window partly open.
- Is the smoke flow impeded by too long a horizontal pipe or too many bends?
- Is it a weak draft perhaps caused by a leaky chimney, a cold outside chimney, too large a diameter of a chimney, too short a chimney, or a chimney too close to trees or a higher roof?
- Has a direct flue connection been used rather than a chimney liner continuous from cap to appliance flue collar.

## 7.0 MAINTENANCE

<b>! WARNING</b>
<b>TURN OFF THE POWER BEFORE SERVICING THE APPLIANCE.</b>
<b>APPLIANCE MAY BE HOT, DO NOT SERVICE UNTIL APPLIANCE HAS COOLED.</b>
<b>DO NOT USE ABRASIVE CLEANERS.</b>

Check your chimney and chimney connector for creosote and soot buildup weekly until a safe frequency for cleaning is established.

If accumulation is excessive, disconnect the appliance and clean both the chimney and the appliance. You may want to call a professional chimney sweep to clean them. Both have to be cleaned at least once a year or as often as necessary.

Remove fibre baffles and clean above them once a year. Replace any broken bricks.

### 7.1 ASH REMOVAL PROCEDURES

<b>! WARNING</b>
<b>IMPROPER DISPOSAL OF ASHES RESULT IN FIRES. DO NOT DISCARD ASHES IN CARDBOARD BOXES, DUMP IN BACK YARDS, OR STORE IN GARAGES.</b>
<b>IF USING A VACUUM TO CLEAN UP ASHES, BE SURE THE ASHES ARE ENTIRELY COOLED. USING A VACUUM TO CLEAN UP WARM ASHES COULD CAUSE A FIRE INSIDE THE VACUUM.</b>
<b>NEVER OPERATE YOUR APPLIANCE WITH THE GRATE COVER REMOVED.</b>
<b>FAILURE TO ACHIEVE A GOOD SEAL BETWEEN THE ASH OPENING AND ASH PLUG WILL RESULT IN AN OVER FIRE CONDITION THAT COULD CAUSE DAMAGE TO THE APPLIANCE.</b>

Allow the ashes in your firebox to accumulate to a depth of two or three inches; they tend to burn themselves up. When the fire has burned down and cooled, remove any excess ashes but leave an ash bed approximately 1 inch deep on the firebox bottom to help maintain a hot charcoal bed.

**DISPOSAL OF ASHES:** Ashes should be placed in a metal container with a tight fitting lid. The closed container of ashes should be placed on a non-combustible floor or ground, well away from all combustible materials, pending final disposal. If the ashes are disposed of by burial in soil or otherwise locally dispersed, they should be retained in the closed container until all cinders have thoroughly cooled.

### 7.2 CREOSOTE FORMATION AND REMOVAL

When wood is burned slowly, it produces tar and other organic vapours which combine with expelled moisture to form creosote. These vapours condense in the relatively cooler chimney flue of a slow burning fire and when ignited, make an extremely hot fire. So, the smoke pipe and chimney should be inspected monthly during the heating season to determine if a buildup has occurred. If creosote has accumulated it should be removed to reduce the risk of a chimney fire.

### 7.3 RUNAWAY OR CHIMNEY FIRE

Runaway fires can be the result of three major factors:

- Using incorrect fuel, or small fuel pieces which wood normally be used as kindling.
- Leaving the door ajar too long and creating extreme temperatures as the air rushes in the open door.
- Burning your appliance with the ash plug not securely seated.

#### SOLUTIONS:

- Do not burn treated or processed wood, coal, charcoal, coloured paper or cardboard.
- Be careful not to over-fire the appliance by leaving the door open too long after initial start-up. A thermometer on the chimney connector and/or appliance top helps.
- Always operate the appliance with the ash plug properly installed.

#### IN CASE OF A CHIMNEY FIRE:

- Have a well understood plan for evacuation and a place outside for everyone to meet. Prepare to evacuate to ensure everyone's safety.
- Close air inlet on appliance.
- Call local fire department. Have a fire extinguisher handy. Contact local authorities for further information on how to handle a chimney fire.
- After the chimney fire is out, clean and inspect the chimney for stress and cracks prior to lighting another fire. Also check combustibles around the chimney and the roof.

### 7.4 CHIMNEY CLEANING

For serious wood burners, chimney cleaning must be done as needed to avoid chimney fires; the venting systems for controlled combustion appliances may need cleaning as often as once a month. These rates, however, depend on the burning habits of the individual operating the appliance. For example, it is possible to clog a solid fuel appliance chimney in a few days if slow, smoldering fires are burned and the chimney is cold. Wood burners who consistently operate their appliances with appropriately hot fires may infrequently have significant creosote accumulations in the chimney.

Certain items and considerations are important in chimney cleaning:

- Proper tools should be used, including a brush specifically designed for chimney cleaning.
- The chimney connector and dampers as well as the chimney should be cleaned.
- The appliance's firebox and baffle system should be cleaned if needed.
- The chimney should be inspected and repairs made if needed, preferably by a qualified chimney sweep or mason.

## 7.5 DOOR REMOVAL

### ! WARNING

BURNING YOUR APPLIANCE WITH THE DOORS OPEN OR AJAR CREATES A FIRE HAZARD THAT MAY RESULT IN A HOUSE AND OR CHIMNEY FIRE.

DO NOT STRIKE OR SLAM DOOR.

NEVER REMOVE THE DOOR WHEN THE APPLIANCE IS HOT.

Pivot the door open and lift the door and pins off the bushings. Set the door aside being careful not to scratch the paint.

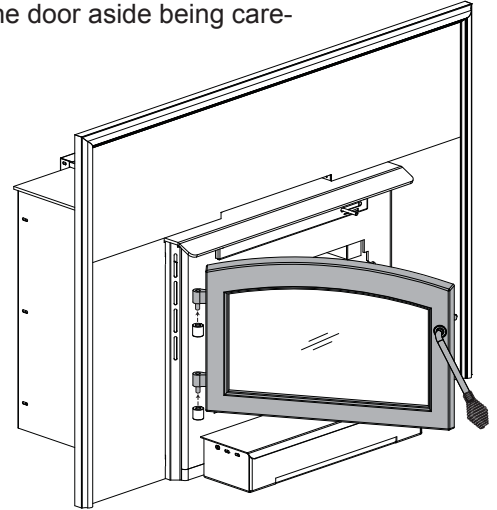

## 7.6 GLASS REPLACEMENT

### ! WARNING

DO NOT USE SUBSTITUTE MATERIALS.

GLASS MAY BE HOT, DO NOT TOUCH GLASS UNTIL COOLED.

CARE MUST BE TAKEN WHEN REMOVING AND DISPOSING OF ANY BROKEN DOOR GLASS OR DAMAGED COMPONENTS. BE SURE TO VACUUM UP ANY BROKEN GLASS FROM INSIDE THE APPLIANCE BEFORE OPERATION.

DO NOT STRIKE, SLAM OR SCRATCH GLASS. DO NOT OPERATE APPLIANCE WITH GLASS REMOVED, CRACKED, BROKEN OR SCRATCHED.

56.1

- 7.6.1 When the appliance is cool, open the door and place the door frame down careful not to scratch the paint.
- 7.6.2 Remove the screws and brackets holding the glass in place. Remove all broken glass.
- 7.6.3 Wrap the edges of the new glass with a U-shaped strip of fiberglass gasket, covering 1/4" on each side.
- 7.6.4 Place the glass with the fiberglass gasket in position and replace the brackets and screws. When finished, you should be able to move the glass slightly, horizontally and vertically.

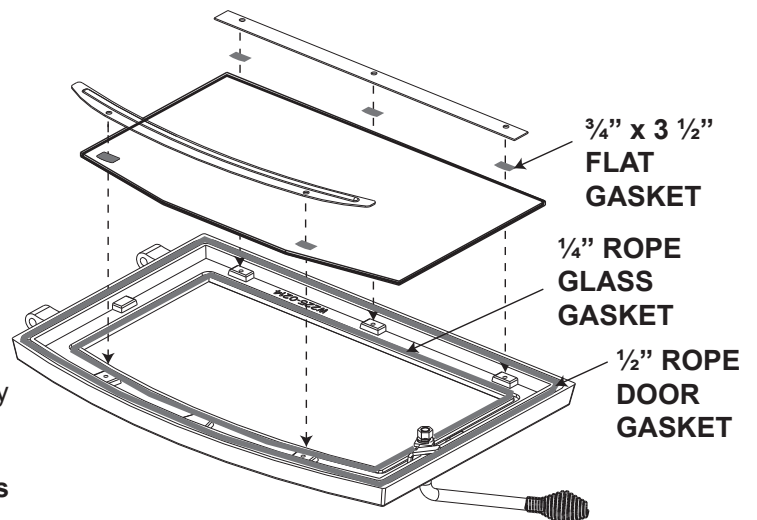

**NOTE:** For replacement glass, size, thickness and specifications see "REPLACEMENTS" section.

## 7.7 CARE OF GLASS

If the glass is not kept clean permanent discolouration and / or blemishes may result. Normally a hot fire will clean the glass. The most common reasons for dirty glass include: not using sufficient fuel to get the appliance thoroughly hot, using green or wet wood, closing the draft so far that there is insufficient air for complete combustion.

If it is necessary to clean the glass, buff lightly with a clean dry cloth and non-abrasive cleaner.



**DO NOT CLEAN GLASS WHEN HOT!** Clean the glass after the first 10 hours of operation with a recommended appliance glass cleaner. Thereafter clean as required.

The glass is very strong but do not let burning fuel rest or fall against it and always close the door gently. **NEVER FORCE IT SHUT!**

If the glass should ever crack or break while the fire is burning, do not open the door until the fire is out and do not operate the appliance again until the glass has been replaced, available from your Authorized dealer. **DO NOT SUBSTITUTE MATERIALS.**

5.3

## 7.8 CARE OF PLATED PARTS

If the appliance is equipped with plated parts, you must clean fingerprints or other marks from the plated surfaces before operating the appliance for the first time. Use a glass cleaner or vinegar and towel to clean. If not cleaned properly before operating for the first time, the marks can cause permanent blemishes on the plating. After the plating is cured, the fingerprints and oils will not affect the finish and little maintenance is required, just wipe clean as needed. Prolonged high temperature burning with the door ajar may cause discolouration on plated parts.

**NOTE:** The protective wrap on plated parts is best removed when the assembly is at room temperature but this can be improved if the assembly is warmed, using a hair dryer or similar heat source.

6.1

## 7.9 GASKET REPLACEMENT

At the end of each burning season inspect the shield and gasket below the manifold for warping or deterioration. Replace if necessary. Both are held to the manifold with machine screws. The shield and the 1/8" fibre cloth gasket are available from your Wolf Steel Ltd. dealer. At this time also check that the door gasket is not worn or loose. Replace with 3/8" high density fibreglass rope if necessary.

The airwash gasket and shield above the door should also be inspected and replaced if deteriorated

**NOTE:** Do not operate appliance if gasket, manifold shield or fibre baffle is deteriorated or missing.

## 7.10 BLOWER SERVICE OR REPLACEMENT

- 7.10.1 Turn off all electrical power to the appliance.
- 7.10.2 Remove the two screws securing the cover to the blower housing.
- 7.10.3 Remove ground wire screw.
- 7.10.4 Remove the four screws securing the retainer and lift the retainer/blowers up and out of the housing.
- 7.10.5 Dust and debris may accumulate, vacuum the blowers and housing prior to re-installation.
- 7.10.6 If blower replacement is required, each blower is attached to the retainer by four screws. Remove the screws to replace or repair.
- 7.10.7 Re-install by reversing the procedure.

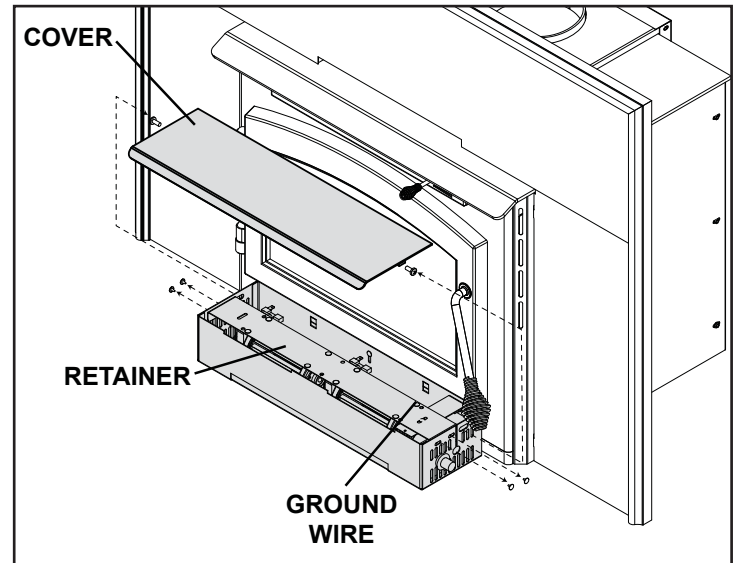

## 7.11 WOOD

Fuel for the appliance must not be stored closer than the required clearances to combustibles (heat sensitive material). **NEVER STORE WOOD IN THE ASH PAN COMPARTMENT.**

Burn only dry, clean unpainted wood that has been seasoned. It produces more heat and less soot or creosote. Freshly cut wood contains about 50% moisture while after proper seasoning only about 20% of the water remains. As wood is burned, this water boils off consuming energy that should be used in heating. The wetter the wood, the less heat is given off and the more creosote is produced.

Both hardwood and softwood burn equally well in this appliance but hardwood is denser, will weigh more per cord and burn a little slower and longer. Firewood should be split, stacked in a manner that air can get to all parts of it and covered in early spring to be ready for burning that fall. Dry firewood has cracks in the end grain. Cut the wood so that it will fit horizontally, front to back, making for easier loading and less of a likelihood that the wood will roll onto the glass. Ideal lengths of wood are approximately 12”.

### DO'S

- Build a hot fire.
- Use only dry wood.
- Several pieces of medium sized wood are better than a few big pieces.
- Clean chimney regularly.
- Refuel frequently using medium sized wood.
- “Fine Tune” the air settings for optimum performance.

### DONT'S

- Take ash out immediately. Let it accumulate to a depth of at least one inch. A good ash layer provides for a longer lasting and better burning fire.
- Burn wet wood.
- Close the door too soon or damper down too quickly.
- Burn one large log rather than two or three smaller, more reasonably sized logs.
- Burn at continually “low setting”, if glass door is constantly blackened. This means the fire-box temperature is too low.

## 8.0 REPLACEMENTS

Contact your dealer or the factory for questions concerning prices and policies on replacement parts. Normally all parts can be ordered through your Authorized dealer / distributor.

**FOR WARRANTY REPLACEMENT PARTS, A PHOTOCOPY OF THE ORIGINAL INVOICE WILL BE REQUIRED TO HONOUR THE CLAIM.**

When ordering replacement parts always give the following information:

- Model & Serial Number of appliance
- Installation date of appliance
- Part number
- Description of part
- Finish

**\* IDENTIFIES ITEMS WHICH ARE NOT ILLUSTRATED. FOR FURTHER INFORMATION, CONTACT YOUR AUTHORIZED DEALER.**

### **WARNING**

**FAILURE TO POSITION THE PARTS IN ACCORDANCE WITH THIS MANUAL OR FAILURE TO USE ONLY PARTS SPECIFICALLY APPROVED WITH THIS APPLIANCE MAY RESULT IN PROPERTY DAMAGE OR PERSONAL INJURY.**

41.1

### COMPONENTS

REF NO.	2201	DESCRIPTION
1*	W325-0042	SPRING HANDLE - SMALL BLACK
1*	W325-0043	SPRING HANDLE - LARGE BLACK
2	W090-0015	BRICK 4.5" X 9"
3	W090-0168	BRICK 4.5" X 6.250"
4	W090-0179	BRICK 2.750" X 9" X 1.250"
5	W090-0018	BRICK 2.250" X 9" X 1.250"
6	W580-0008	COMPLETE BRICK SET
7	W018-0118	FIBRE BAFFLE
8	W225-0214	BLACK DOOR
9*	W010-2325	KIT, REPLACEMENT GLASS & GASKET (INCLUDED GLASS GASKET)
10*	W020-0563	KIT, GLASS GASKET
11	W720-0134	REAR SECONDARY AIR TUBE
12	W720-0135	FRONT SECONDARY AIR TUBE
13*	W385-0487	TIMBERWOLF LOGO
14	W020-0503	ASSY, DOOR HANDLE
15	W062-0024	BLOWER
16	W660-0019	VARIABLE SPEED SWITCH
17	W690-0002	THERMAL SWITCH
18	W380-0002	KNOB
19	W263-0107	FLASHING, RS
20	W263-0106	FLASHING, TOP
21	W263-0108	FLASHING, LS
22	W715-0687	TRIM, RIGHT SIDE BLACK
23	W715-0685	TRIM, TOP BLACK
24	W715-0686	TRIM, LEFT SIDE BLACK
25	W020-0021	HARDWARE, TRIM (CORNER CLIPS)
26	W160-0014	SPRING CLIP
27*	W020-0043	KIT, DOOR GASKET

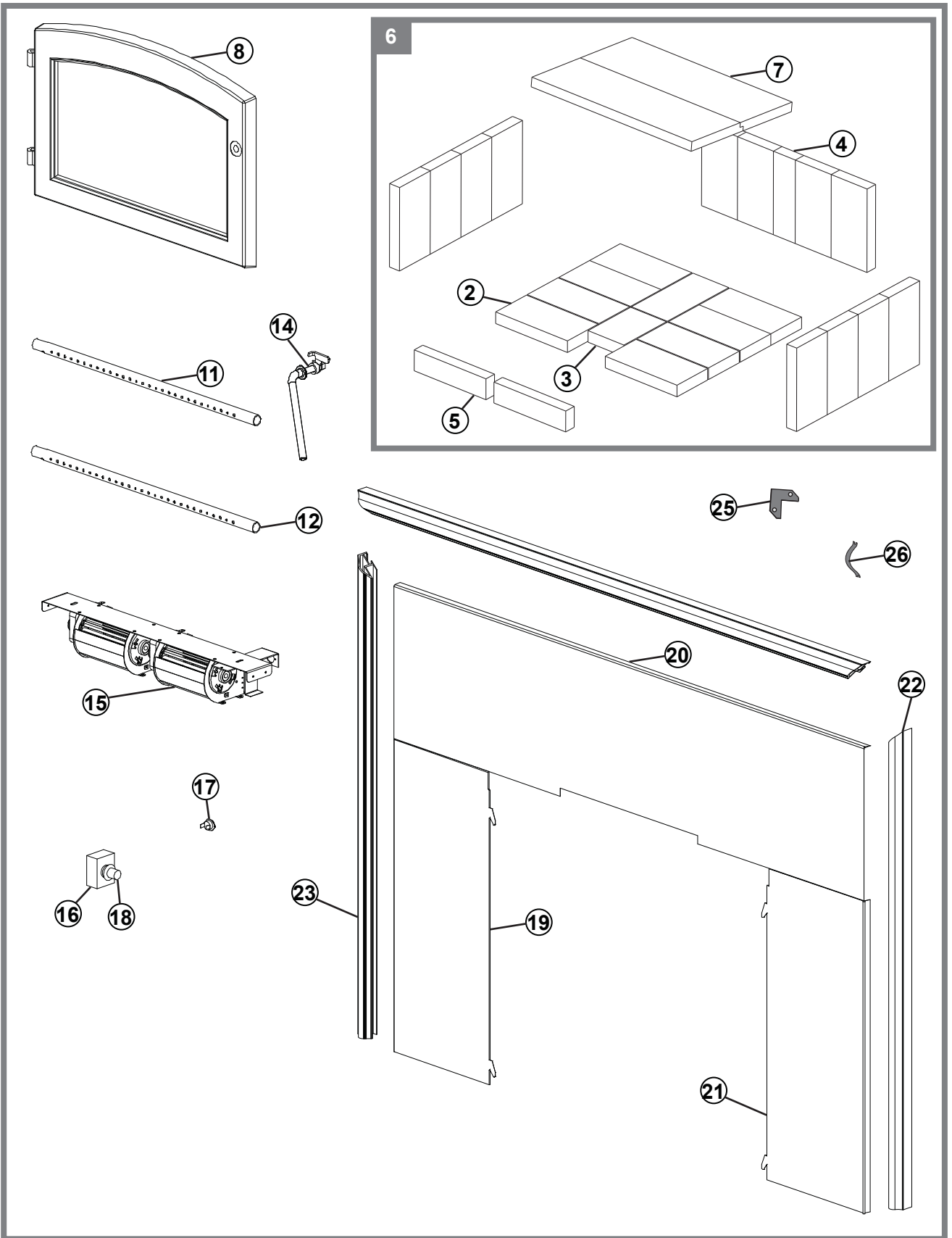

## 9.0 TROUBLE SHOOTING

### WARNING

TURN OFF THE ELECTRICAL POWER BEFORE SERVICING THE APPLIANCE.

APPLIANCE MAY BE HOT, DO NOT SERVICE UNTIL APPLIANCE HAS COOLED.

DO NOT USE ABRASIVE CLEANERS.

WHEN CHECKING CONNECTIONS, INSTALLING JUMPER WIRES (FOR TEST PURPOSES ONLY) OR REPLACING COMPONENTS, UNPLUG HEATER FROM THE RECEPTACLE TO PREVENT ELECTRICAL SHOCK OR DAMAGE TO THE COMPONENT.

PROBLEM	SOLUTION
Can't get the fire.	<ul style="list-style-type: none"> <li>- Not enough kindling / paper? Add more.</li> <li>- Not enough air? Ensure air control is fully open.</li> <li>- Cold air blockage? Burn a piece of paper to establish a draft.</li> <li>- Use dry seasoned wood.</li> <li>- Flue blockage? Inspect chimney.</li> </ul>
Smokes when door is open.	<ul style="list-style-type: none"> <li>- Cold air blockage? Burn a piece of paper to establish a draft.</li> <li>- Insufficient draft? Add more pipe.</li> <li>- Let air stabilize before opening door.</li> <li>- Ensure baffles are positioned correctly.</li> <li>- Negative pressure? Open a window near the appliance.</li> </ul>
Appliance emits odour.	<ul style="list-style-type: none"> <li>- Paint curing. See "GENERAL INSTRUCTIONS" section.</li> </ul>
Stove doesn't burnt hot enough.	<ul style="list-style-type: none"> <li>- Wood is too wet.</li> <li>- Insufficient draft? Add more pipe.</li> <li>- Not enough air? Ensure air control is fully open.</li> </ul>
Wood burns too fast.	<ul style="list-style-type: none"> <li>- Air control may need to be adjusted down.</li> <li>- Check to see ash plug is properly seated.</li> <li>- Check door gasket for adequate seal.</li> <li>- Wood may be extremely dry.</li> </ul>
Dirty glass.	<ul style="list-style-type: none"> <li>- Air control may be closed too far.</li> <li>- Burn hotter, smaller fires.</li> <li>- Use well seasoned wood.</li> </ul>
Blower does not run.	<ul style="list-style-type: none"> <li>- Appliance may not be up to temperature.</li> <li>- Ensure blower has power.</li> </ul>

## 10.0 WARRANTY

TIMBERWOLF products are manufactured under the strict Standard of the World Recognized ISO 9001 : 2008 Quality Assurance Certificate.

TIMBERWOLF products are designed with superior components and materials, assembled by trained craftsmen who take great pride in their work. The complete appliance is thoroughly inspected by a qualified technician before packaging to ensure that you, the customer, receives the quality product that you expect from TIMBERWOLF.

### **TIMBERWOLF WOOD APPLIANCE PRESIDENT'S LIMITED WARRANTY**

The following materials and workmanship in your new TIMBERWOLF appliance are warranted against defects as defined below:

The combustion chamber is warranted against defects for a period of 25 years.

The secondary air tubes are warranted against defects for a period of five years.

All other wearable parts and electrical components such as blowers, thermal switches, switches, wiring, rheostats, firebrick, ceramic glass (thermal breakage only), fibre baffles and gasketing are covered and Wolf Steel will provide replacement parts free of charge during the first year of the limited warranty.

Any labour related to warranty repair is not covered.

\* Construction of models vary. Warranty applies only to components included with your specific heater.

### **CONDITIONS AND LIMITATIONS**

Wolf Steel warrants its TIMBERWOLF products against manufacturing defects to the original purchaser only. Registering your warranty is not necessary. Simply provide your proof of purchase along with the model and serial number to make a warranty claim. Provided that the purchase was made through an authorized TIMBERWOLF dealer your appliance is subject to the following conditions and limitations:

This factory warranty is non-transferable and may not be extended whatsoever by any of our representatives.

The appliance must be installed by an authorized service technician or contractor. Installation must be done in accordance with the installation instructions included with the product and all local and national building and fire codes.

This limited warranty does not cover damages caused by misuse, lack of maintenance, accident, alterations, abuse or neglect. Operating the appliance on high for extended periods of time, is neglect. Parts installed from other manufacturers will nullify this warranty.

This limited warranty further does not cover any scratches, dents, corrosion or discoloring caused by excessive heat, abrasive and chemical cleaners nor chipping on porcelain enamel parts, nor any venting components used in the installation of the appliance.

In the first year only, this warranty extends to the repair or replacement of warranted parts which are defective in material or workmanship provided that the product has been operated in accordance with the operation instructions and under normal conditions.

After the first year, with respect to the TIMBERWOLF'S President's Limited Warranty, Wolf Steel may, at its discretion, fully discharge all obligations with respect to this warranty by refunding to the original warranted purchaser the wholesale price of any warranted but defective parts.

After the first year, Wolf Steel Ltd. will not be responsible for installation, labour or any other costs or expenses related to the reinstallation of a warranted part, and such expenses are not covered by this warranty.

Notwithstanding any provisions contained in the TIMBERWOLF'S President's Limited Warranty, Wolf Steel's responsibility under this warranty is defined as above and it shall not in any event extend to any incidental, consequential or indirect damages.

This warranty defines the obligations and liability of Wolf Steel with respect to the TIMBERWOLF appliance and any other warranties expressed or implied with respect to this product, its components or accessories are excluded.

Wolf Steel neither assumes, nor authorizes any third party to assume, on its behalf, any other liabilities with respect to the sale of this product. Wolf Steel will not be responsible for: over-firing, downdrafts, spillage caused by environmental conditions such as rooftops, buildings, nearby trees, hills, mountains, inadequate vents or ventilation, excessive venting configurations, insufficient makeup air, or negative air pressures which may or may not be caused by mechanical systems such as exhaust blowers, furnaces, clothes dryers, etc.

Any damages to appliance, combustion chamber, heat exchanger or other components due to water, weather damage, long periods of dampness, condensation, damaging chemicals or cleaners will not be the responsibility of Wolf Steel.

Regular cleaning of the fine ash generated during the operation of this appliance is a necessary part of maintaining your appliance. Failure of any components, which is attributed to poor maintenance, is not warrantable and will not be covered by this policy.

Wolf Steel reserves the right to have its representative inspect any TIMBERWOLF product or part thereof prior to honouring any warranty claim.

ALL SPECIFICATIONS AND DESIGNS ARE SUBJECT TO CHANGE WITHOUT PRIOR NOTICE DUE TO ON-GOING PRODUCT IMPROVEMENTS.





