



*You'll find Thermalboard™ under the best warm floors*

# THERMALBOARD™

*The radiant system for how you build*

The hydronic radiant heating that everyone loves is now more efficient, more responsive, and compatible with standard construction practices. Ideal for new construction and remodeling alike, with its low profile, light weight and rapid response. Thermalboard™ delivers a genuine advance in the best heating system you can buy... hydronic radiant heat.

## Why it works so well...

Non-structural Thermalboard™ is designed specifically for subfloor applications. Thermalboard™ is constructed of a dense composite board covered with aluminum that spreads the heat evenly and quickly. Thermalboard™ heats rapidly and is easy to control with setback thermostats for maximum energy efficiency. It contains just enough thermal mass to be effective, but not so much that it's difficult to control. No other product combines the performance, ease of installation and cost-effectiveness.

### CONSTRUCTION FRIENDLY

Thermalboard™ is installed using conventional construction practices and commonly used tools. With a layout plan, the three Thermalboard™ panel patterns can be systematically arranged on the subfloor. Not only are the boards light weight -- they're also easy to handle, cut and attach to the subfloor.

### COST FRIENDLY

Thermalboard™ avoids joist upsizing, double plating and hardwood nailing strips associated with gypsum-based concrete radiant heating systems. Also, Thermalboard™ eliminates substantial drying costs required by moisture-laden concrete and gypsum-based cement. Time is money. Thermalboard™ eliminates scheduling and curing delays.

### FLOORING FRIENDLY

Thermalboard™ provides a quality flat surface for floor covering assemblies:

- HARDWOOD
- ENGINEERED WOOD
- TILE/STONE
- CARPET
- VINYL/RESILIENT FLOORING
- LAMINATE

Each of these flooring assemblies are supported by detailed drawings and instructions such as these illustrated below. Consult our application guide for greater detail.

### PLANET FRIENDLY

Thermalboard™ employs fully recyclable wood and a recyclable aluminum alloy. It is made of recovered and recycled materials.

Testing by Environmental Analysis, Inc. has revealed no measurable outgassing.

EAI Project #0107-090.



### QUICK INSTALLATION:

In three easy steps, Thermalboard™ can be efficiently installed by specialty Thermalboard™ radiant installers or by a trained general contractor.

Thermalboard™ is cut to size, glued, then either screwed or pneumatically stapled to a standard subfloor in a pattern to accommodate the PEX tubing layout needed for that particular space -- to fulfill the room's heating requirements.

The three easily understood board shapes are usually assembled with very little cutting to form the groove layout for the 3/8" PEX tubing. When cutting is required, you can use conventional circular saws, radial arm saws or table saws.

Finished flooring goods may then be easily installed over Thermalboard™, with reference to our installation manual. Download other tips and considerations from our website. Third party layout documentation and submittal services are available.



[www.Thermalboard.info](http://www.Thermalboard.info)

#### CARPET

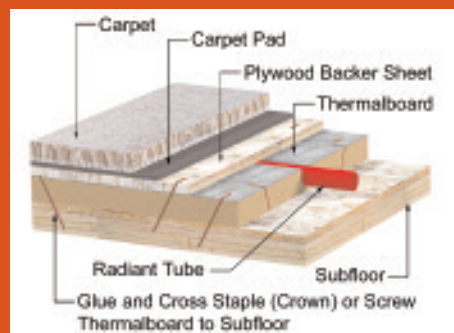

#### ENGINEERED WOOD

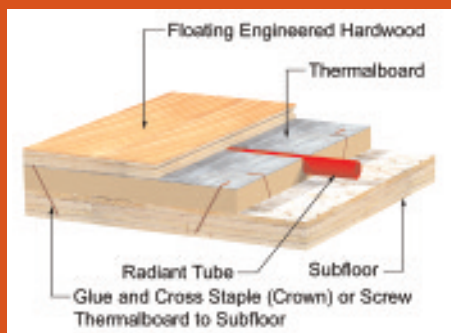

#### TRADITIONAL WOOD

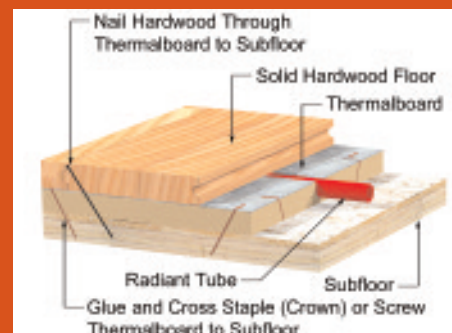

#### LAMINATE

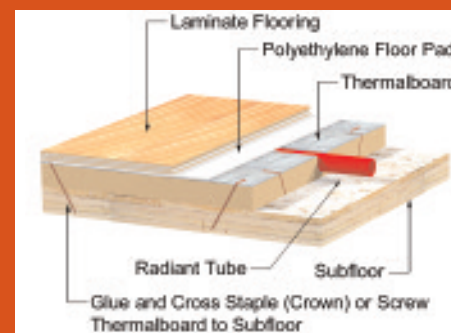

#### TILE

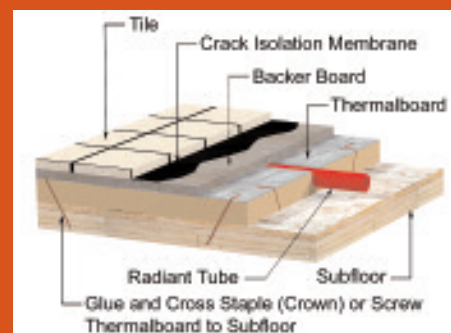

#### VINYL

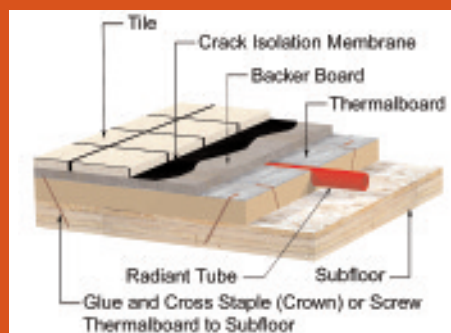

*Many floorings, such as hardwoods, may be installed directly over Thermalboard. Thermalboard saves on work, materials, time and money when compared with other thermal mass options.*

# THERMALBOARD™

## SPECIFICATIONS

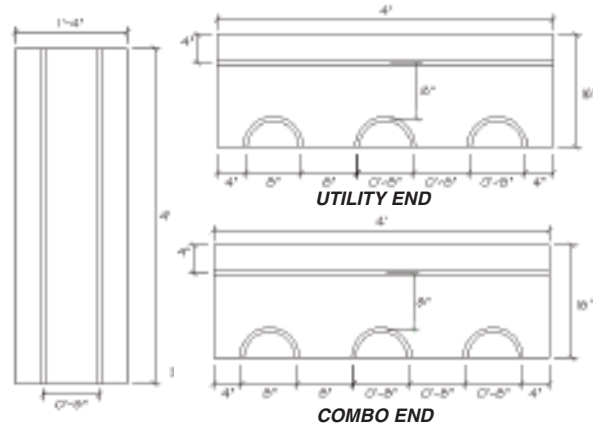

**Dimensions:** Each board is 16" x 48" x 5/8" thick.  
**Square Footage:** 5.333<sup>sq.ft.</sup> per board  
**Weight:** Approximately 2.5 pounds per sq.ft., 13.3 pounds per board  
**Pallet Size:** 4' x 4' x 24" tall (99 Thermalboards per pallet; 528<sup>sq.ft.</sup>)  
**Approximate Pallet Weight:** 1280 pounds  
**Approximate Truckload:** 16,885.44<sup>sq.ft.</sup>, or 33 pallets, or 42,214 lbs.  
**Pallet Appearance:** Shrink-wrapped, corner protected, color coded corners by part #  
**Recommended Product Mix:** Straight, 70%; Combo End, 15%; Utility End, 15%;  
 \* Allow 10% extra for waste.

## DESIGN AND SUBMITTAL LAYOUT SERVICES

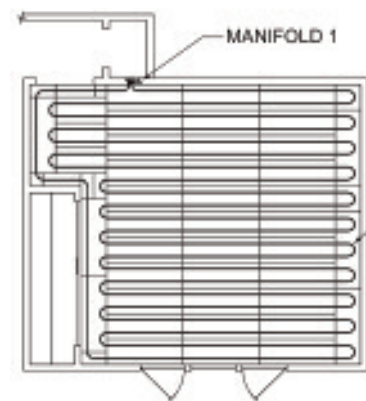
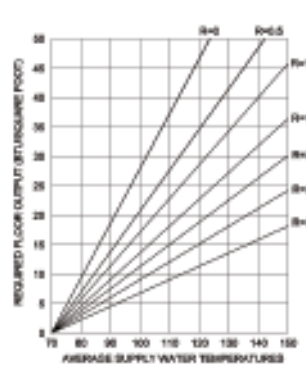

PANEL SCHEDULE	
TYPE	QUANTITY
STRAIGHT	36
UTILITY	3
COMBO	4

**Thermalboard™ panel layout services are available from your Thermalboard™ distributor. These submittal services provide CAD drawings of the proper panel combinations to accept the PEX radiant tubing. Plans must be submitted electronically.**

**Layout technicians will require client flooring goods selections, including hardwood orientation, for each room, as well as manifold location preference. Separate heat loss and complete system design services available.**

Distributed By:

JTG/Muir  
 Manufacturer's Representative  
 P.O. Box 8772  
 Emeryville, CA 94662  
 (510) 548-2373  
 (510) 548-4091 fax  
 jtgmuir.com



# THERMALBOARD™

## Quick Response

### MODULAR HYDRONIC RADIANT HEATING SYSTEM

- Low profile, light weight for easy installation
- Avoid the moisture, weight and mess of gypsum cement or concrete
- Radiant Installations -- big or small -- can be easily scheduled with no lost concrete curing time
- Cost effective -- a great value in radiant heat.

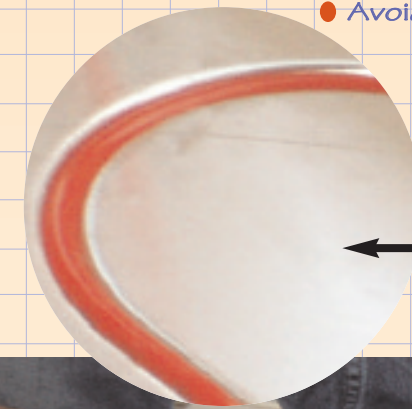

← Thin dense board with an aluminum layer means quick acceleration

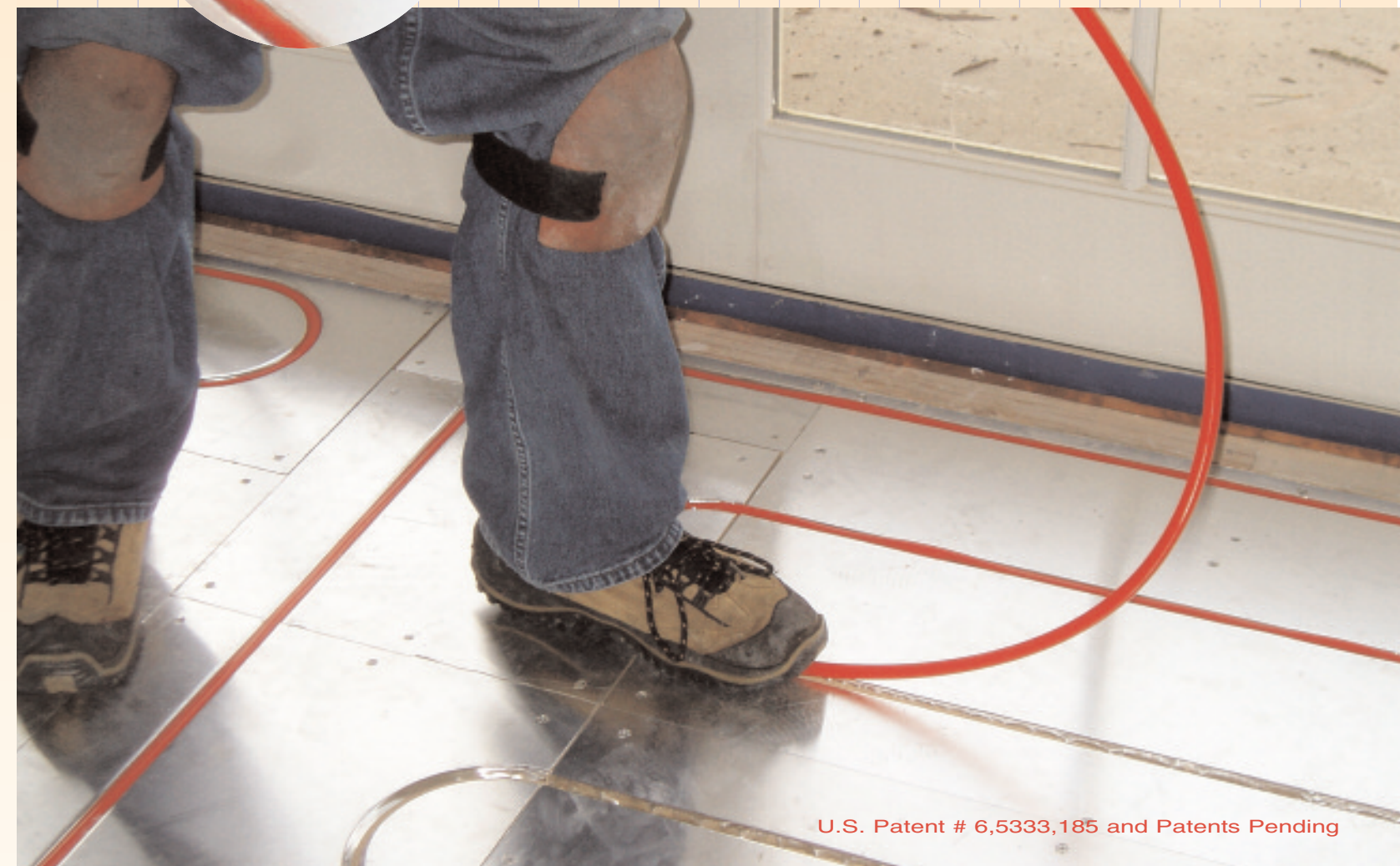

U.S. Patent # 6,533,185 and Patents Pending