

**HeatTransfer**

Advanced Heating and  
Hot Water Systems

**HP-30SC  
Solar Collector  
Evacuated Tube  
Installation  
Manual**



## SPECIAL ATTENTION BOXES

The following defined terms are used throughout this manual to bring attention to the presence of hazards of various risk levels or to important information concerning the product.

### DEFINITIONS

#### **⚠ DANGER**

**DANGER** indicates an imminently hazardous situation which, if not avoided, will result in death or serious injury.

#### **⚠ CAUTION**

**CAUTION** Indicates a potentially hazardous situation which, if not avoided, may result in minor or moderate injury.

#### **⚠ WARNING**

**WARNING** indicates a potentially hazardous situation which, if not avoided, could result in death or serious injury.

#### **CAUTION**

**CAUTION** used without the safety alert symbol indicates a potentially hazardous situation which, if not avoided, may result in property damage.

## THE FOLLOWING IS A SUMMARY OF KEY SAFETY PRECAUTIONS. PLEASE READ CAREFULLY

### METALLIC COMPONENTS

- a) Always wear leather protective gloves when handling solar collector components. All efforts have been made to make the metal components safe to handle, but there may still be some sharp edges.

### EVACUATED TUBES

- a) Be careful when handling the evacuated tubes, as they will break if knocked heavily or dropped.
- b) If exposed to sunlight and therefore hot (have internal pressure built up), the tubes may explode rather than implode if knocked and broken. This is a rare occurrence, but nevertheless safety precautions should be taken.
- c) If the evacuated tubes are struck by a hard object with sufficient force (ie. branch falling on roof), they may break. During installation consideration should be taken as to the possible path any broken glass may take. Where possible protection should be implemented to prevent broken glass from reaching ground level where somebody could walk on it (ie. Guttering on roof).
- d) The home owner should be made aware by the Installer the location of the solar collector and the possible vicinity of broken glass in the event of an extreme storm or object falling on the collector.

### HIGH TEMPERATURES

- a) With the heat pipe installed in the evacuated tube, and good sunlight, the heat pipe tip can reach temperatures in excess of 200°C / 392°F. At this temperature touching the heat pipe will result in serious burns, so thick leather gloves must be worn when handling hot tubes and heat pipes.
- b) In an installed fully plumbed system, if the pump is stopped during good sunlight the collector header and plumbing pipe close to the manifold can easily reach temperatures in excess of 160°C / 320°F, and therefore caution should be taken when handling such components.

### HEALTH & SAFETY

- a) Always wear safety glasses when handling evacuated tubes
- b) Wear leather gloves when handling metal components
- c) Wear thick leather gloves if handling hot heat pipes
- d) Adhere to safety regulations regarding working on roofs (or at a height)
- e) Always obtain engineer approval for installations in high wind regions.

### NOTICE

*Heat Transfer Products, Inc., reserves the right to make product changes or updates without notice and will not be held liable for typographical errors in literature.*

## CONTENTS

<b>Part 1 – Important Information</b> .....	<b>3</b>
1.1. Local Standards .....	3
1.2. Authorized Person(s) .....	3
1.3. Pressure and Temperature Control and Relief .....	3
1.4. Water Quality .....	3
1.5. Metallic Corrosion .....	4
1.6. Freeze protection .....	4
1.7. Collector Dimensions & Weights .....	4
1.8. Manifold Formats (End or Rear) .....	5
1.9. Wind Stress .....	5
1.10. Snow Load .....	5
1.11. Storage Tanks .....	5
1.12. Hail Resistance .....	6
1.13. Scope of Manual .....	6
1.14. Terminology .....	6
<b>Part 2 – Installation</b> .....	<b>6</b>
2.1 Transport, Unpacking and Inspection .....	6
2.2 System Design .....	7
2.3 Mounting Frame .....	10
2.4 Flush Pitched Roof Installation (Standard Frame) .....	12
2.5 Low Pitched Roof Installation (Low or Mid Angle Frame) .....	13
2.6 Flat Roof Installation (High Angle Frame) .....	14
2.7 Wall Mounting (using Low, Mid, High or Fixed Angle Frames) .....	14
2.8 Connection to Plumbing .....	15
2.9 Evacuated Tube & Heat Pipe Installation .....	19
2.10 Post Installation .....	20
2.11 Precautions .....	21
<b>Part 3 – Maintenance</b> .....	<b>21</b>
3.1. Cleaning .....	22
3.2. Leaves .....	22
3.3. Broken Tube .....	22
3.4. Insulation .....	23
3.5. Draining the Collector .....	23
3.6. Other Components .....	23
3.7. Freezing .....	23
<b>Part 4 – Troubleshooting</b> .....	<b>24</b>
4.1. No Hot Water .....	24
4.2. Reduced Solar Contribution .....	24
4.3. Regular Water Dumping .....	24
<b>Part 5 – Installation Checklist</b> .....	<b>25</b>
<b>Appendix A</b> .....	<b>27</b>
<b>Appendix B</b> .....	<b>28</b>
<b>Appendix C</b> .....	<b>29</b>
<b>Appendix D</b> .....	<b>30</b>
<b>Appendix E</b> .....	<b>31</b>
<b>Appendix F</b> .....	<b>32</b>

# PART 1: IMPORTANT INFORMATION

## 1.1. LOCAL STANDARDS

- a) Installation must be completed in accordance with relevant local standards and regulations.

## 1.2. AUTHORIZED PERSON(S)

- a) Installation must be completed by a qualified tradesperson, who holds relevant industry licenses or certificates required for the work completed during the installation process.
- c) The term “authorized person(s)” used throughout this document refers to a suitably qualified professional.
- d) Unless otherwise specified in section 3, no part of the HTP Inc. solar collector may be inspected, repaired or maintained by anybody other than an authorized person(s).

## 1.3. PRESSURE AND TEMPERATURE CONTROL AND RELIEF

- a) For open loop systems, the normal operating pressure should be <500kPa / 72.5psi via use of a pressure limiting (pressure reduction) valve on the main cold supply line.
- b) For open loop systems, it is acceptable for the system design to allow the solar collector to stagnate to prevent additional heating of the storage tank (i.e. pump stoppage once tank temperature reaches 80°C / 177°F). The pressure relief valve must be able to release the pressure increase that occurs when the manifold stagnates, and should be rated to meet the maximum possible heat output of the solar collector(s). Please see section 3.4 regarding insulation of piping for high temperatures, and section 2.2.3 regarding overheating.
- c) For closed loop systems, the solar loop must operate at <500kPa / 72.5psi, and have an expansion vessel installed to control water expansion. The system design MUST NOT allow stagnation of the collector as a standard form of controlling tank temperature, as this may cause damage to the glycol.
- d) Any system design must provide means for allowing pressure release at no more than 850kPa / 123psi, or as specified by local regulation. Also check the maximum pressure ratings for any components of the system and design for the weakest link.
- e) It is recommended, and may also be a local regulation, that the pressure/temperature relief valve have a copper pipe connected, running the expelled hot water or air to a safe and appropriate drainage location.

## 1.4. WATER QUALITY

- a) Water in direct flow through the manifold header must firstly meet potable water requirements and, in addition, the following:

<b>Total dissolved solids</b>	600 p.p.m	<b>Total hardness</b>	< 200 p.p.m. ÷ 17.1 = 11.7 grains
<b>Chloride</b>	< 250 p.p.m.	<b>Free Chlorine</b>	< 5 ppm
<b>Magnesium</b>	< 10 p.p.m.		

- b) In areas with “hard” water (>200ppm), lime scale may form inside the header pipe (where a direct flow format is used). In such regions, it is advisable to install a water softening device to ensure the long term efficient operation of the collector, or use a closed loop for the solar circulation loop.
- c) If using a glycol/water mix, the water must meet the above requirements, and the glycol content of the liquid must not exceed 50%, unless the manufacture specifies that a different ratio is recommended for use with solar water heaters. Glycol may need to be changed periodically (every 3-5 years) to prevent the glycol from becoming acidic; please refer to the guidelines provided by the glycol manufacturer regarding replacement times.
- d) In order to meet health and safety regulations, glycol used should be food grade

## **PART 1: IMPORTANT INFORMATION (CONTINUED)**

polypropylene glycol.

### **1.5. METALLIC CORROSION**

- a) Both copper & stainless steel are susceptible to corrosion when, amongst other factors, high concentrations of chloride are present. The solar collector may be used for heating of spa or pool water, but levels of free chlorine must not exceed 5ppm, otherwise the copper header could be corroded.
- b) HTP Inc. does not warrant the solar collector against corrosion related damage.

### **1.6. FREEZE PROTECTION**

Freeze protection must be implemented in any region that experiences freezing conditions at any time throughout the year.

- a) For areas with temperature not falling below 23°F / -5°C, simple low temp controller based freeze protection may be used. (i.e. Pump circulates if the manifold temperature approaches freezing). If possible, backup protection in the form of uninterrupted power supply (UPS) or freeze valves (which open to allow water to dribble out) should also be installed.
- b) For areas with temperatures below 23°F / -5°C, a closed loop filled with a polypropylene glycol-water mix should be used to provide freeze protection. Please refer to glycol manufacturer’s specifications about the temperature ranges the liquid can withstand. Only food grade polypropylene-glycol should be used.
- c) Evacuated tubes are not susceptible to damage in cold weather, and heat pipes are protected against damage that could result from the freezing of the water inside.
- d) HTP, Inc. does not warrant the solar collector against freeze related damage.

### **1.7. COLLECTOR DIMENSIONS & WEIGHTS**

HP-30SC = 210lb / 95.5kg

Overall Length 80"/1980mm Overall Height 6.14"/155mm (manifold & standard frame)

<b>Collector Size</b>	<b>30 tubes</b>
<b>Overall Width<sup>3</sup></b>	86.4" / 2196 mm
<b>Absorber Area<sup>4</sup></b>	25.8 ft <sup>2</sup> / 2.4 m <sup>2</sup>
<b>Aperture Area<sup>5</sup></b>	30.3 ft <sup>2</sup> / 2.82 m <sup>2</sup>
<b>Gross Area</b>	46.8 ft <sup>2</sup> / 4.35 m <sup>2</sup>
<b>Gross Dry Weight (Standard Frame)</b>	208.5 lb / 94.8 kg
<b>Fluid Capacity</b>	24 fl oz / 710 ml

- 1. Length of frame front track
- 2. Height of frame front track + manifold
- 3. Width of manifold (not including inlet/outlet ports)
- 4. Absorber = Outside diameter of inner tube x exposed tube length
- 5. Aperture = Inner diameter of outer glass tube x exposed tube length

## **PART 1: IMPORTANT INFORMATION (CONTINUED)**

### **1.8. MANIFOLD FORMATS (END OR REAR)**

- a). For the end port manifolds, flow in either direction is acceptable, Please refer to the following diagram.

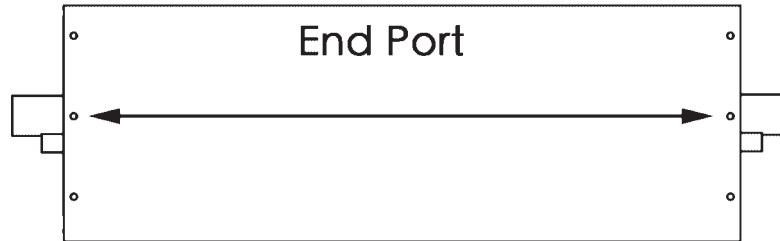

### **1.9. WIND STRESS**

- When installing the collector, please consider the issue of wind resistance, and the resultant stress on attachment points. Please adhere to relevant building codes/regulations regarding installation of such objects.
- The standard frame, and frames kits all designed to withstand wind speeds of up to 120mph / 190km/h without damage.
- For flush mounting on a pitched roof, a minimum of two attachment points per front track must be made, each with a minimum pull strength of 220lb / 100kg. If this is not able to be achieved, additional attachment points must be made to achieve minimum strength levels.
- If installing the low, mid, high or fixed angle roof frames, a minimum of two attachment points per front track must be made, each with a minimum pull strength of 150kg / 330lbs. If this is not able to be achieved, additional attachment points must be made to achieve minimum strength levels. See Appendices A through E for frame assembly details.
- It is the responsibility of the installation contractor to ensure that the frame mounting is of suitable strength. Where applicable inspection by building department officer or equivalent should be completed to ensure the installation is in accordance with relevant regulations.

### **1.10. SNOW LOAD**

- In areas prone to heavy snow falls the solar collectors should ideally be installed at an angle of 50° or greater to help promote snow sliding off the tubes. In addition it is advisable to raise the front of the collector frame 15-20cm off the roof surface as this allows the collector to sit above moderate snow falls and also more easily blow away from under the collector. See the picture to the right. A front track extension (Part #: FR-FTRACK-EXT) can be used for this purpose.
- Each tube is strong enough to withstand > 135 lbs. loading, but roof attachment points may need to be reinforced. Please refer to local regulations regarding snow loading precautions.

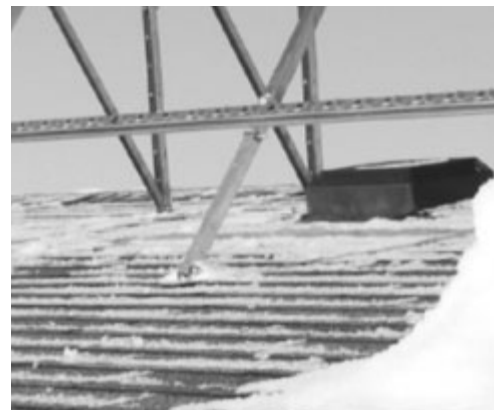

### **1.11. STORAGE TANKS**

- Glass lined storage tanks: Please note that if the water heater is left in an operating condition and not used for two weeks or more, a quantity of hydrogen (which is highly flammable) may accumulate in the top of the water cylinder. To dissipate this gas safely it is recommend that a hot water tap be turned on for several minutes at a sink, basin or bath but not a

## **PART 1: IMPORTANT INFORMATION (CONTINUED)**

dishwasher, clothes washer or other appliance. During this process there must be no smoking or open flame or any other electrical appliance operating nearby. If hydrogen is discharged through the tap it will usually sound like air escaping.

- b) Pressure Relief Valve: The storage tank's pressure and temperature relief valve and the drain outlet pipe must not be sealed or blocked. It is normal for the valve to release small amounts of water during heating cycles.

### **1.12. HAIL RESISTANCE**

- a) The glass evacuated tubes are surprisingly strong and able to handle significant impact stresses once installed. Testing and impact stress modeling proves that the tubes are able to withstand impact from hail up to 1" / 25mm in diameter, and even larger when installed at angle of 40° or greater. The ability of the evacuated tubes to withstand impact from hail is greatly influenced by the angle of impact, and so installing the collectors at low angles does reduce their impact resistance.
- b) It is recommended that in areas prone to large hail (> 3/4" / 20mm) the solar collector should be installed at an angle of 40° or greater to provide optimum protection. As many populated areas in the world fall within the latitude of ±30-70° this is generally a common installation angle.
- c) If in the unlikely circumstance that a tube should become broken, it can be easily replaced. The solar collector can still function properly with one or more broken tubes, however a reduction in heat output will result (depending upon how many tubes are broken). A broken tube should be replaced by authorized persons only.

Please refer to section 3.3 for more details on tube replacement.

### **1.13. SCOPE OF MANUAL**

- a) This manual pertains only to the installation and operation of the HTP Solar Collector. Details for the installation, operation and maintenance of the complete solar gas/electric water heating system including, but not limited to storage tank, gas/electric booster, pump, system controller, valves and other plumbing components should be provided separately by their respective manufacturers.
- b) This manual is primarily a reference document for installation officers, as the solar collector is not permitted to be installed by non-authorized persons.

### **1.14. TERMINOLOGY**

The terminology used from region to region differs and so to avoid confusion please note the following terminology:

- a) "supply", indicates the plumbing line running from the outlet of the collector back to the tank.
- b) "return" indicates the plumbing line running from the tank (or heat exchanger) to the inlet of the collector. This line incorporates the circulation pump.
- c) Wrench = Spanner
- d) Insolation = solar radiation level, expressed in Btu/ft<sup>2</sup>/day or kWh/m<sup>2</sup>/day

## **PART 2: INSTALLATION**

### **2.1 TRANSPORT, UNPACKING AND INSPECTION**

#### **2.1.1. Transport**

- a) When possible, transport the boxes of evacuated tubes standing upright, taking notice of the

## PART 2: INSTALLATION (CONTINUED)

THIS WAY UP arrows. If the boxes can only be laid down, always place on a flat, firm surface such as a compressed wooden board. If stacking the boxes, ideally do not exceed 3 layers and ensure they are strapped down in place to avoid movement. Straps should be padded with thick cardboard or similar at box corners to avoid cutting into the boxes.

### 2.1.2. Component List

- a) Please familiarize yourself with the components listed on the packing list, which is included in the collector manifold packing box. If any components are missing, or additional parts are required, please contact your supplier who will have spares in stock.

### 2.1.2. Tube & Heat Pipe Inspection

- a) Open the tube box(es), which contain the evacuated tubes with heat pipes inserted. Check to make sure the evacuated tubes are all intact, and the bottom of each tube is still silver colored. If a tube has a white or clear bottom, it is damaged and should be replaced. The heat pipe should be removed from the damaged tube and inserted into a replacement tube. Replacement tubes are available from your local HTP, Inc dealer who supplied the solar collector.
- b) As soon as the evacuated tubes are removed from the box, please put on the rubber tube caps, which are located in the manifold box. This will protect the bottom tip of the glass tube from being broken if knocked.
- e) Heat pipes are bright and shiny when newly manufactured, but will dull and may form dark-grey surface discoloration over time. This is due to mild surface oxidation (when exposed to air) and is perfectly normal and does not affect the integrity of the heat pipe.
- d) Do not remove and/or expose the tubes to sunlight until ready to install, otherwise the heat pipe tip will become very hot, sufficient to cause serious skin burns. The outer glass surface will not become hot.



### ⚠ CAUTION

**NEVER TOUCH THE INSIDE OF THE EVACUATED TUBE OR HEAT PIPE TIP AFTER EXPOSURE TO SUNLIGHT. WEAR THICK LEATHER GLOVES IF HANDLING THE HEAT PIPE. WEAR SAFETY GLASSES AT ALL TIMES WHEN HANDLING THE GLASS TUBES.**

- e) HTP, Inc does not warrant the tube or heat pipes against failure as a result of damage incurred during transport or installation.

### 2.1.3. Frame

- a) Unpack the standard frame that is provided together with the manifold. If a frame kit is being used, those components will be packed separately from the manifold. See Appendix A for standard frame diagram.
- b) Depending on the roof surface, rubber pads, roof attachment straps or round feet may be used to attach the standard frame to the roof. These components are supplied separately from the standard frame.

## 2.2 SYSTEM DESIGN

### 2.2.1. System Design

- a) System design should be completed prior to commencing installation. Solar collectors need to be installed correctly to ensure high efficiency, and most importantly, safe and reliable operation. Please seek professional advice for the design and installation of your solar heating system. Only authorized licensed contractors are permitted to install the solar collector.

## PART 2: INSTALLATION (CONTINUED)

### ⚠ CAUTION

**HTP, Inc., does not provide warranty coverage and will not be held liable for any damage to person or property that results from solar collectors that are installed by unauthorized persons.**

#### 2.2.2. Delta-T Controller Settings

- a) Usually a Delta-T ON value of 7-11°F / 4-6°C and Delta-T OFF value of 3.6°F / 2°C is appropriate. These settings may need to be altered slightly according to the location and system design. Refer to the instruction manual provided with the chosen solar controller for appropriate settings.

#### 2.2.3. Stagnation and Overheating

- a) Stagnation refers to the condition that occurs when the pump stops running, due to pump failure, power outage, or as a result of a high tank temperature protection feature built into the controller, which turns the pump off.
- b) If the system is designed to allow stagnation as a means of preventing tank overheating, the collector and plumbing in close proximity may reach temperatures of >395°F / 200°C; therefore components that may be exposed to the high temperatures such as valves, plumbing or insulation, should be suitably rated.
- c) If the system is designed to allow stagnation of the collector when the tank reaches a set maximum level, steam may form in the header (depending on the system pressure). In such a system, a temperature relief valve or auto air vent should NOT be installed on the collector outlet, as they may not be able to withstand the high temperatures and will not allow stable stagnation of the collector (may dump hot water). The pressure and temperature relief valve on the tank may open to release pressure or heat as required. Under such conditions the collector manifold will normally reach a maximum temperature of around 320°F / 160°C. Any heat returning from the collector is generally not enough to cause a continued increase in tank temperatures (i.e. Heat input is less than tank heat losses), and therefore is able to meet requirements in force in some regions regarding limiting tank hot water dumping. A crackling noise may be heard down the supply line when hot water is used, as the pressure in the system drops and steam forms, this is normal.

#### 2.2.4. Correct System Sizing to Avoid Overheating

- a) The system should be sized so that overheating of the tank is difficult to achieve in a single day, even during hot, sunny periods. If the system is over-sized, such that excessive heat is often produced during summer months, a heat dissipater unit, or alternative cooling/dissipation system should be installed.

#### 2.2.5. Solar for Central Heating – Preventing Overheating

- a) If a system has been designed to provide a contribution to space heating, it will sometimes provide more heat in the summer than is required for hot water supply alone. In such cases, it is advisable for the home to have a hot-tub / Jacuzzi or pool that can use the heat in the summer period, a large storage tank or underground thermal store, or a heat dissipater unit(s) should be installed. See also the following point (2.2.6), regarding reduction of summer heat output.

#### 2.2.6. Adjusting Collector Angle to Ease Overheating

- a) Apart from installing a smaller collector, a good method of reducing summer heat output is to angle the collector for optimal winter absorption. This is achieved by installing the collector at an angle of around 15° above the latitude angle. This angle corresponds closely to angle of the sun in the sky during the winter months, thus maximizing winter output.

## PART 2: INSTALLATION (CONTINUED)

Conversely, during the summer when the sun is high in the sky, the relative surface area of the collector exposed to sunlight is reduced, in effect reducing overall heat production considerably (by about 15%). This option is ideal for installations where solar thermal is being used for space heating.

### 2.2.7. Collector Direction

- a) The collector should face the equator, which if in the Northern Hemisphere is due south, and vice versa. Facing the collector in the correct direction and at the correct angle is important to ensure optimal heat output from the collector, a deviation of up to 10° from due South is acceptable, and will have minimal effect on heat output

### 2.2.8. Collector Plane

- a) The collector manifold is normally installed on the flat horizontal plane, however may be installed at an angle such as when installed sideways on a pitched roof.
- b) The collector must not be installed up-side-down (tubes pointing upwards) or with tubes lying horizontally, as the heat pipes will not function.

### 2.2.9. Collector Angle

- a) It is common for collectors to be installed at an angle that corresponds to the latitude of the location. While adhering to this guideline, an angle of latitude +/- 10° is acceptable, and will not greatly reduce solar output. See also point 2.2.6.
- b) The solar collector should be installed at an angle of between 20-80° to ensure optimal heat pipe operation.

### 2.2.10. Avoid Shade

- a) Collectors should be located so that shading does not occur for at least the 3 hours either side of 12 noon local time.
- b) Partial shading due to small objects such as antennas and small flues, is not of great concern.

### 2.2.11. Location

- a) The collector should be positioned as close as possible to the storage tank to avoid long pipe runs. Storage tank location should therefore be considered as part of the location requirements of the solar collector.
- b) The storage tank should be located as close as possible to the most frequent draw off points in the building.

### 2.2.12. Expansion Tank – Minimizing water wastage

#### **⚠ WARNING**

**In any hot water system, be it solar, gas, electric or combination thereof, expansion of water will occur as the water heats up. When water expands, it has to be controlled, as it cannot be compressed like air. See below for requirements pertaining to your application.**

- a) In open loop systems have a check valve/non-return valve on the cold main. In order to prevent this wasteful dumping of water, it is recommended that an expansion tank be installed.
- b) Closed loop systems should always be installed with an expansion tank. The volume of the tank usually equates to 2-3% of the volume of the water in the system. Refer to the expansion tank manufacturers' guidelines regarding correct sizing.

## PART 2: INSTALLATION (CONTINUED)

- c) In an un-pressurized open vented system expansion tank is required.

### 2.2.13. Lightning Protection

- a) It is advisable to earth/ground the copper circulation loop of the collector to avoid lightning related damage or electrical safety issues.

### 2.2.14. Pipe Connections & Pipe Size

- a) HTP Solar Collectors are provided as standard with 3/4" OD copper pipe inlet and outlet pipe.
- b) For domestic heating applications with 1 or 2 collectors, nominal 1/2" / 15mm piping is suitable.
- c) For applications using 2 or more solar collectors in series, it is advisable to use a nominal 3/4" / 20mm piping.
- d) For A connection of banks of collectors, larger pipe sizes should be used as required for the given application, with consideration made to flow rates, pressure drop and pump sizing.
- e) The material used for the solar loop must be able to withstand the operating temperatures and pressures to which the system may be exposed, due to normal or extraordinary conditions (e.g. pump failure or power outage). Copper pipe is the most widely used piping material for solar applications. If it is decided to use synthetic piping for the plumbing, HTP, Inc strongly recommends that copper pipe is still used for at least the first 12 feet of the line connecting to both the inlet and outlet of the collector.

### 2.2.15. Connection of Multiple Collectors

- a) When connecting END port collectors in series (maximum of 150 tubes), flexible connections should be used between each collector in order to allow for the expansion and contraction of the copper header with temperature changes. Failure to use flexible connections between consecutive END port collectors may result in damage to the header if the system stagnates.

## ⚠ CAUTION

**HTP, Inc., does not warrant the collector against damage resulting from poorly managed header expansion and contraction.**

### 2.2.16. Potable Water

- a) If the system is direct flow, meaning that potable water is flowing through the collector, any components used in the system must meet potable water requirements.

## 2.3 MOUNTING FRAME

HTP, Inc., solar collectors are supplied with a standard frame, which is suitable for flush mounting on a suitably pitched roof. For installation on low-pitched roofs, flat roofs or off walls, additional frame kits are available. Depending on the roof surface, the standard frame may attached to the roof with rubber pads (corrugated steel, asphalt) or roof attachment straps (tiled roofs).

### 2.3.1. Frame Material

- a) All frame components are made of .059" (1.5 mm) thick stainless steel making the frame both strong and corrosion resistant. It is important that frame attachment points and externally supplied fasteners are also of suitable structural strength and corrosion resistance.

## PART 2: INSTALLATION (CONTINUED)

### 2.3.2. Galvanic Reaction between SS and Zinc Galvanized Steel

#### ⚠ CAUTION

**Zinc galvanized components should NOT be installed in direct contact with stainless steel, as galvanic reaction between the two metals can cause premature oxidation of the zinc coating and the steel underneath**

- If the roof surface is galvanized steel, refer to section 2.4.4 for installation guidelines.
- Avoid using galvanized steel bolts; instead use stainless steel components. If galvanized components are used, avoid direct contact between the two metals by using the rubber/plastic separators, such as a rubber frame pad

### 2.3.3. Roof Installation

Three types of roof installations are outlined in this guide:

- Flush installation on a suitable roof. See section 2.4
- Installing on a roof with insufficient pitch. See section 2.5
- Installing on a flat surface. See section 2.6
- Installing on a wall. Section 2.7

### 2.3.4. Manifold and Bottom Track Attachment

- Both the manifold and frame bottom track are secured to the frame front tracks using special attachment plates. These plates are already attached to the front tracks when shipped, so they only have to be loosened to allow the manifold and bottom track to be fitted.
- The plates are designed such that when loose, the manifold and bottom track are able to slide left and right. This allows the front tracks to be easily adjusted to suit the roof surface.
- Once correctly located, the nuts should be tightened using the supplied spanner/wrench, locking the manifold and bottom track in place.
- Note that the bolts are up-side-down with the nut on top. This allows the thread to be viewed and as such prevents the installer from loosening the bolt so much that the nut drops off. The bolt head is prevented from rotating by use of a lock nut, removing the need to use a second wrench.
- Spring washers are supplied to ensure that the stainless steel bolts do not loosen over time. Stainless steel bolts are not as hard as hardened steel bolts, and therefore care should be taken not to over-tighten the nuts, as this can damage the thread, making it difficult to undo.

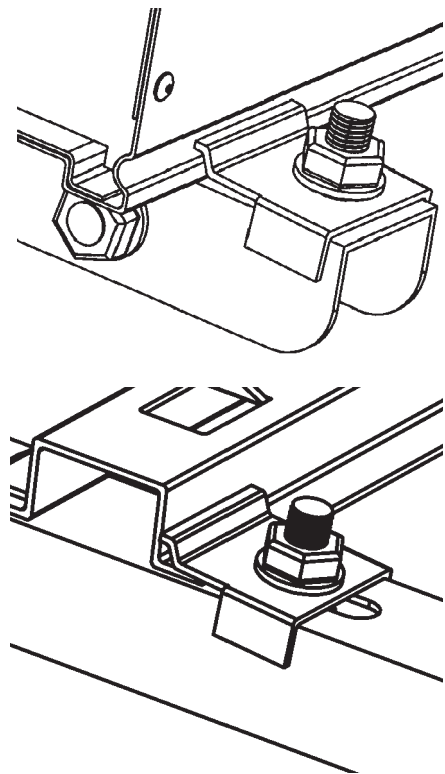

### 2.3.5. Customizing the Frame

- The standard frame, low, mid, high and fixed angle roof frame components can be used creatively to suit a range of different installation formats. Additional holes may be drilled in the frame as required, but the frame structural integrity must not be compromised (e.g., don't drill holes too close together).

## PART 2: INSTALLATION (CONTINUED)

### 2.3.6. Roof Attachment

- a) In order to meet strength requirements in areas with winds up to 130mph / 208km/h and category "D" exposure, the following attachment format should be followed. Any other installation format should be approved by a local engineer.

#### Mount on Flat Roof using Round Feet

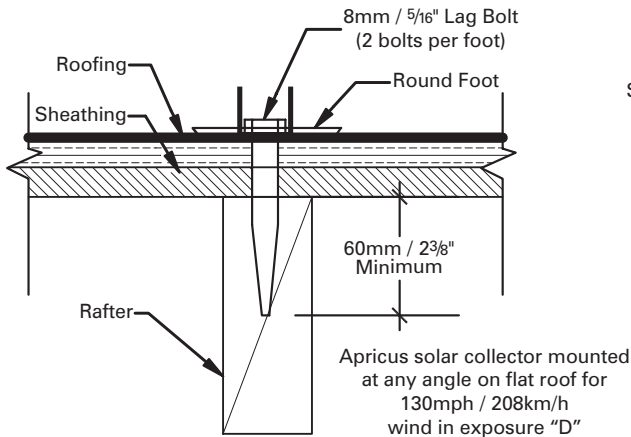

#### Flush Mount on Pitched Asphalt Shingle Roof

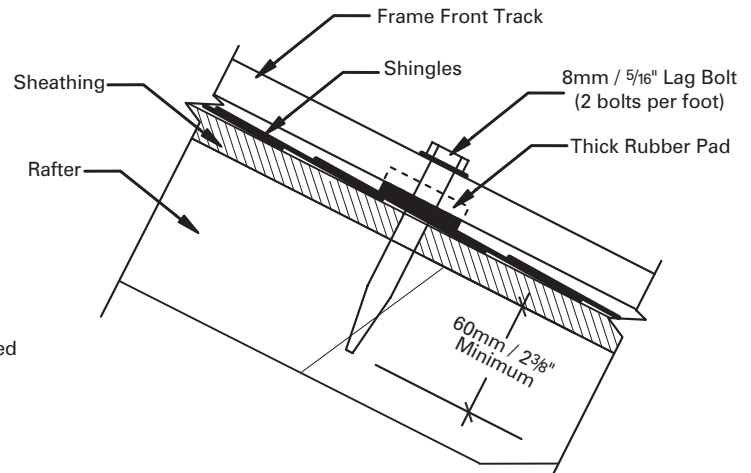

#### Angle Mount on Pitched Asphalt Shingle Roof

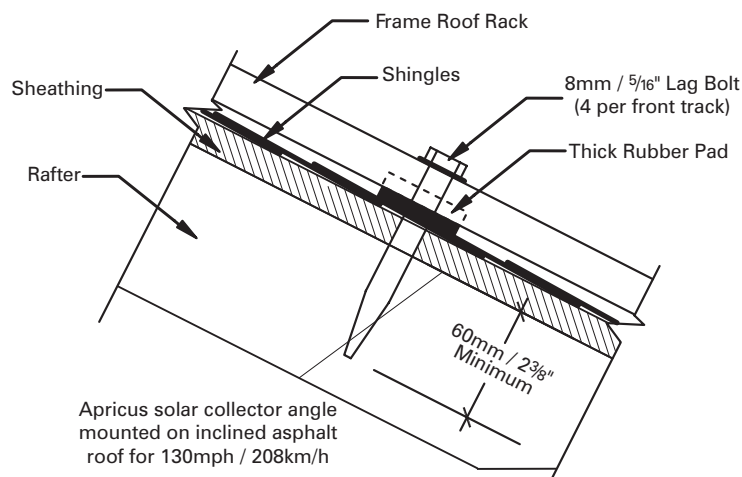

## 2.4 FLUSH PITCHED ROOF INSTALLATION (STANDARD FRAME)

Refer to Appendix A for assembly diagram.

### 2.4.1. Installation Planning

- a) For tiled roofs, carefully plan the location of the manifold, frame front tracks and plumbing pipes in order to minimize the number of tiles that need to be removed (and returned into

## PART 2: INSTALLATION (CONTINUED)

place). Tiles may have holes cut to allow the roof straps or bolts to pass through. Any holes must be covered and/or sealed with standard roofing materials to avoid leaks.

### 2.4.2. Positioning Manifold

- a) The manifold and bottom track can slide left and right in relation to the frame front tracks, so there is some flexibility when selecting the location. The frame front tracks should be located such that they lay flat and even on the roof (match the tiles/shingles) and also line up with the roof frame.
- b) If possible try to locate front tracks under the 2nd or 3rd tube from each end. By locating the front tracks directly under the evacuated tubes, the stainless steel frame will be hidden, improving the aesthetics of the installation. For collectors with three front tracks, the middle front track should be positioned roughly centrally, again ideally behind a tube. The horizontal brace (Part #: FR-HBRACE) provided with the standard frame kit provides an indication of the standard location of the front tracks. Additional holes may be drilled in the horizontal brace to meet different front track locations. See also 2.3.5.

### 2.4.3. Tiled Roof Attachment

- a) For tiled roofs, the ~2' / 60cm or ~3' / 100cm long roof attachment straps can be used (2 per front track). One end of each strap should be secured to the underside of the frame front tracks using the supplied M8-20 bolts and nut lock assemblies, the other end to structurally secure roof framing using M8 (0.3" / 8mm diameter) or thicker bolts or screws (only use stainless steel screws or bolts). Please ensure that roof-anchoring points are of suitable structural integrity. Once the upper straps are attached and tightened, adjust the bottom straps to ensure that they too are providing support to the frame.

### 2.4.4. Corrugated Iron Roof

- a) For installation on a corrugated iron roof, the standard thickness rubber pad can be used to separate the frame from the roof and also to seal the hole. Use a standard corrugated iron roofing screw to secure the frame front track directly to the roof's wooden frame (additional holes may need to be drilled in the frame front track).
- b) If the roofing screw is zinc galvanized steel, it should have a rubber/nylon washer, which will prevent direct contact with the stainless steel frame.
- c) The rubber pad will form a tight seal against the roof, preventing any water ingress. Addition of some silicone sealant beneath the pad and inside the hole is advisable.
- d) This mounting method is also suitable when attaching the roof tracks used in the low or mid angle roof frame when using the roof track option. (See section 2.5)

### 2.4.5. Asphalt Shingle Roof

- a) For installation on an asphalt shingle roof, the same method as outlined in 2.4.4 can be used, with the difference that the extra thick rubber pad (#FR-TRPAD) should be used to compensate for the pad sinking into the asphalt.

### 2.4.6. Manifold and Bottom Track Attachment

- a) Once the front tracks are secured in place, the manifold and bottom track may be attached, taking care to ensure they are correctly aligned. Both the manifold and bottom track will lock into the frame, secured from above with the attachment plates that are already in place.

## 2.5 LOW PITCHED ROOF INSTALLATION (LOW OR MID ANGLE FRAME)

If the roof pitch is insufficient, a low or mid angle roof frame kit can be used to increase the angle by 12° or 27° respectively. Low or mid angle frame kits combine with the standard frame components to form a complete frame assembly.

## PART 2: INSTALLATION (CONTINUED)

### 2.5.1. Frame Options

Two frame options are available, round feet or roof tracks.

- a) Round Feet are suitable for attachment to concrete or asphalt shingle roofs on which the round foot twin bolt attachment is preferred. Round feet allow some front and back movement of the rear legs, thus slightly adjusting the install angle.
- b) Roof tracks are ideal when rubber pads are the preferred attachment method and provide a fixed install angle. Mounting of the roof tracks to the roof should be completed in the same way as the front tracks, as outlined in section 2.4.
- c) In cases where either option is viable, round feet provide the most cost effective solution.

### 2.5.2. Rear X Brace Adjustment

- a) The rear X brace components have a series of elongated holes to allow adjustment of the location of the legs. If further adjustment is needed, additional holes may be drilled to suit.

## 2.6 FLAT ROOF INSTALLATION (HIGH ANGLE FRAME)

The high angle frame is appropriate for installations on flat surfaces and provides adjustment from 30-50°. The high angle frame kit combines with the standard frame components to form the complete frame assembly.

### 2.6.1. Frame Feet Anchoring

- a) Frame feet should be bolted to the installation surface using 0.4" / 10mm diameter or larger bolts, or a similarly sturdy fastening method. Only stainless steel bolts should be used.

### 2.6.2. Adjusting Frame Angle

- a) The rear legs of the high angle frame comprise two interlocking pieces (top and bottom leg), which allow the length of the rear leg to be adjusted, thus changing the collector angle from between 30° and 50°.

## ⚠ WARNING

**Ensure the surface is solid and able to withstand in excess of 150kg / 330lbs of pull force that may be encountered during high winds. Consult a structural engineer if in doubt.**

- b) Each pair of legs (top and bottom) must always be attached together by 2 bolts (two sets of holes).
- c) If an angle less than 30° is required, a low angle frame kit should be sourced. Rather than making adjustments to the high angle frame, it is much easier to directly use a low or mid angle frame.
- d) If an angle greater than 50° is required the mounting points of the rear feet may be raised (i.e. on concrete blocks). Raising the angle greatly increases the horizontal force during high winds, and as such should be considered.

## 2.7 WALL MOUNTING (USING LOW, MID, HIGH OR FIXED ANGLE FRAMES)

Refer to Appendix F for assembly diagram.

### 2.7.1. Wall Frame Options

- a) If mounting on a wall, low, mid, high or fixed angle frames may be used, with the legs reversed, so attached to the bottom of the front tracks rather than the top.

## PART 2: INSTALLATION (CONTINUED)

### 2.7.2. Attachment Methods

- a) The method used for attachment to the wall will depend on the wall material. For brick or concrete walls, the round feet can be used, secured with stainless steel expansion bolts.
- b) For wood or synthetic boarding, stainless steel screws that can penetrate into the wall framework may be suitable. If the strength of such screw attachment is of concern it is advisable to use bolts that run directly through the wood, with a large washer or metal plate positioned before the nut.

### **⚠ WARNING**

**Always consider the weight of the collector and the structural integrity of the wall. HTP, Inc. requires that installations be inspected and approved by authorized building inspectors and comply with state and local codes.**

- c) Take note to adhere to the maximum collector angle of 80°, otherwise heat pipe performance may be reduced.
- d) When installing on a wall, consider the possible shading from eaves, particularly in the summer. This in fact may be a part of the system design, in order to minimize summer heat output. Another advantage of installing under an eave overhang is to minimize snow buildup on the collector in areas with regular snowfall. Even with snow sitting on the bottom of tube, the heat pipes will work effectively to conduct heat, as the inner tube temperature becomes fairly even for the full length of the tube due to heat transfer by the aluminum fins.
- e) If using round feet at the top of the front tracks to bolt to the wall, the rear corners of the manifold attachment plates will need to be ground slightly to allow for the round foot.
- f) If installing on a wall such that the collector is above a walkway, please consider the danger associated with broken glass that could fall if the tubes were ever damaged. (e.g. during an extreme storm due to flying debris, or tree branch falling on the collector). It may be necessary for a barrier to be installed below the collector to catch any such falling materials.

## 2.8 CONNECTION TO PLUMBING

### 2.8.1. Plumbing Connection

- a) Once the frame has been mounted and the manifold attached, the manifold header may be connected to the system plumbing.
- b) If the collector is to be installed (including evacuated tubes) prior to plumbing connection (e.g. on new house), high temperature resistant covers should be placed over the header inlet and outlet to prevent any contaminants entering the header (e.g. aluminum foil). The solar collector will not be damaged by a short period of dry stagnation (<14 days).

### 2.8.2. Temperature Sensor Insertion

- a) The temperature sensor port is located beside the inlet and outlet ports. Generally the temperature should be sensed at the outlet of the manifold.
- b) The solar controller's temperature sensor should be coated with a thin layer of thermal paste and inserted into the sensor port to the full depth. If the fit is too loose, slide a piece of copper or stainless steel plate/wire in beside the sensor.
- c) Ensure that the insulation tightly covers the opening to prevent water ingress. Use a silicone sealant if required to ensure a watertight seal against the manifold.
- d) Ensure that sensors used on the collector are high temperature rated (up to 395°F / 200°C), in particular, the cable.

## PART 2: INSTALLATION (CONTINUED)

### 2.8.3. Header connection

- a) Compression Fitting: To ensure a sound seal, use plumbing thread glue or Teflon tape over the top of the copper olive ring. Tighten using two wrenches, taking care not to stress the copper pipe. Do not over tighten.
- c) Brazing/Sweating/Soldering or a flared fitting (P/N 8600-031) to the header is acceptable, but care must be taken to avoid exposing the manifold casing to the torch flame. Ideally place a wet cotton cloth around the base of the header pipe to reduce the temperature of the copper pipe in contact with the silicone rubber seal.

### 2.8.4. Air Purge

- a) Once the inlet and outlet are connected to the plumbing system, the collector loop should be purged of air (see also 2.8.3).
- b) Main Pressure Open Loop – for a system without an auto-air vent installed, a drain valve on the supply line should be fitting along with a ball valve on the tank side. With the ball valve closed, the drain valve can be opened to allow air to escape as the main's water pressure forces through the line.



### ⚠ CAUTION

The water may be hot, with even some steam being released if the collector is hot.

Once the drain valve is no longer releasing air it can be closed and the ball valve opened so that normal operation can begin. If an auto-air vent is installed on the outlet of the collector, air will be automatically eliminated from the solar line. If using a manual air vent this should be opened until all air is eliminated.

- c) Low Pressure Open Loop – run the pump at the highest speed settings, forcing air out of the manifold and back into the tank. If an auto-air vent is installed on the outlet of the collector, air will be automatically eliminated from the solar line. If using a manual air vent this should be opened until all air is eliminated. Air vent shut off valve should be closed after commissioning and removed if not high temperature rated.
- d) Closed Loop – the solar loop should be filled with glycol/water mix, vented and pressurized. The exact process will depend on the design of the loop and components used – refer to relevant instructions specific to the pump station/heat exchanger used.
- e) When using END port manifolds, additional attention should be made to ensure the header is fully cleared of air, by running the pump at full speed to force the air out. If a low speed pump is being used, ideally raise the outlet end of the header slightly (if possible) to facilitate more complete removal of air.

### 2.8.5. Plumbing Check

- a) Once plumbing is confirmed as leak free and with all air having been purged, the heat pipes and evacuated tubes may be installed.

### 2.8.6. Glycol Freeze Protection

- a) Only use food grade polypropylene glycol.
- b) Ideally use glycol with additives that provide resistance to breakdown during high temperatures.
- c) Glycol should be checked (pH) and replaced periodically as specified by the glycol manufacturer.

## PART 2: INSTALLATION (CONTINUED)

### 2.8.7. Insulation

- a) Heavily insulate all piping running to and from the manifold with a high quality insulation of at least 0.6" / 15mm thickness, preferably thicker in cold climates. Heat loss from the piping can be significant, and so particular attention should be taken to insulate any possible points of heat loss.
- b) Ensure the insulation is tight against the manifold casing, thus minimizing loss of heat from the inlet and outlet. In order to prevent water from entering the temperature probe port and/or in between the piping and insulation foam, a high quality silicone sealant should be used to form a water-tight seal.
- c) Insulation foam that is exposed to direct sunlight should be protected against UV related degradation by wrapping/covering with a suitable material such as adhesive back aluminum foil, PVC conduit or similar.
- d) For systems designed to allow stagnation, high temperature rated insulation such as glass wool or mineral wool should be used on piping close to the collector (6' / ~2m). Glass wool insulation may come with an external foil wrap, but any cuts made during installation should be sealed with watertight and UV stabilized material such as adhesive backed aluminum foil.
- e) Circulation pumps can be a source of significant heat loss and should be insulated. Some pumps come standard with a molded foam casing which has good insulation properties. If the pump does not have any insulation, the same foam style insulation used on the plumbing pipe can be used to cover the pump, secured in place with good quality nylon cable ties or adhesive tape.

### ⚠ NOTICE

**Certain pumps are not designed to be insulated, please contact the pump manufacturer if in doubt.**

- f) All internal piping, as well as external piping should be insulated. This includes at least the 3" closest to the hot water outlet of the tank, as this copper pipe is a significant point of passive heat loss.

### 2.8.8. Pump Selection

- a) The pump should provide enough pressure to enable circulation through the collector header, but preferably only at a slow rate (0.026G/tube each minute). Apart from wasting electricity, a fast flow rate will cause turbulent mixing of the water in the storage tank in direct flow systems, disturbing temperature stratification, which is not desirable.
- b) If the water pressure used in the solar loop is sufficient to fill the header passively, then the pump is simply required to circulate the water. The key consideration is therefore the pressure drop throughout the pipeline. Elbows, tees, and bends in piping all contribute to pressure drop. For this reason, the flow path should be kept as simple and unrestricted as possible.
- c) Pressure drop through an HTP 30 tube header with cold water at 0.79gpm / 3L/min is only 900Pa / 0.13psi. See graph below for pressure drops at flow rates up to 1.32gpm / 5L/m.
- d) For single story/floor houses where the pipe run to and from the collector is no more than 27 feet / 8m, a small 25-30 Watt pump with low head pressure (~50kPa / 7psi) may be sufficient. Two or 3 story houses where the pump run is longer, a 60-70Watt pump may be required. The use of a 3 speed pump is recommended, as an appropriate speed setting can easily be chosen (e.g. 40, 60 & 90 Watt multi-speed pump).

## PART 2: INSTALLATION (CONTINUED)

e) To determine if the pump chosen is suitable the following methods can be used:

### HP-30SC 30-Tube Collector Pressure Drop

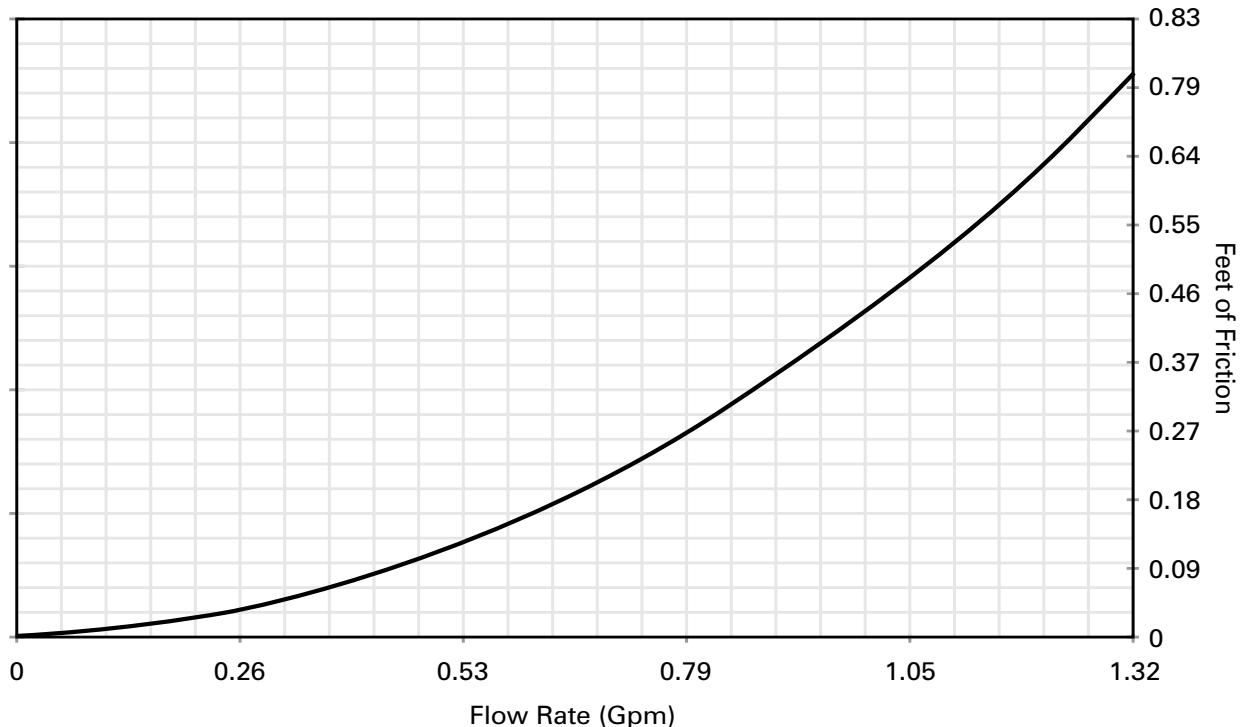

- i). If a flow meter is installed on the supply line, a visual indication of flow rates can be provided.
  - ii). If a flow meter is NOT installed, observing pump operation can reveal if sufficient flow is being achieved. Under normal conditions with sunny weather, the pump should cycle on and off. If the pump is cycling more than once every 2-3 minutes or running continuously, the flow rate may be insufficient. A faster than required flow rate might be indicated by a very short pump operation time of less than 20 seconds.
  - iii). If a solar controller with an LCD temperature display is used, the solar collector and tank temperatures may be monitored. Under normal operation, the manifold temperature should gradually increase (speed will depend on solar radiation levels). In good sun, it should only take 3-5 min. for the manifold to increase to the Delta-T ON level (12-18°F / ~7-10°C). Once the pump turns on, the header temperature should initially increase by 2-3 degrees as the hot water in the header passes by the sensor. Over a subsequent period of 30-60 seconds, the header temperature should gradually drop back down, the pump turning off once the Delta-T OFF level is reached.  
 If the manifold temperature does not gradually decrease once the pump turns on, then it may indicate insufficient circulation. If the temperature drops too quickly, the circulation speed may be faster than required, wasting electricity and causing unnecessary turbulence on return to the storage tank (if applicable).
  - iv). If the system does not seem to be flowing properly, check for air locks in the lines.
- f) Always use hot water rated pumps (up to 232°F / 110°C), as temperatures close to boiling can be experienced. The pump should always be installed on the tank to collector line, thus reducing exposure to extreme temperatures. In addition, a check valve should always be installed after the pump to prevent backflow, and possible thermosiphoning at night.

## PART 2: INSTALLATION (CONTINUED)

### 2.9 EVACUATED TUBE & HEAT PIPE INSTALLATION

The HTP solar collector is a simple “plug in” system. The heat pipe and evacuated tube assembly just needs to be plugged into the manifold. The contact between the heat pipe condenser/tip and heat pipe port in the header needs to be tight in order to ensure good heat transfer. Under normal use, once the heat pipes are installed they should never have to be removed, even if replacing a damaged evacuated tube.

#### **⚠ WARNING**

**DO NOT INSTALL THE HEAT PIPES AND EVACUATED TUBES UNTIL SYSTEM PLUMBING IS COMPLETED AND PUMP AND CONTROLLER ARE OPERATIONAL, UNLESS THE SYSTEM, IN PARTICULAR INSULATION, IS DESIGNED TO WITHSTAND HIGH TEMPERATURE STAGNATION, OR TUBES ARE COVERED.**

Please follow the instructions below for assembly and installation:

#### 2.9.1. Unpacking

- The heat pipes and evacuated tubes are packed in the same box, with heat pipes already inserted into the evacuated tubes.
- Open the bottom of the box to expose the ends of the tubes, placing a rubber caps on each tube. This protects the tubes from accidental damage.
- Do not expose tubes to sunlight until ready to install, otherwise the heat pipes will become extremely hot, and could cause serious burns if touched. Wear thick protective gloves if handling hot tubes & heat pipes.

#### **⚠ WARNING**

**WEAR SAFETY GLASSES AT ALL TIME WHEN HANDLING EVACUATED TUBES.**

- Heat pipes contain a small amount of copper powder which aids in heat transfer and provides protection against freeze related damage to the heat pipe. To ensure that the powder is at the bottom of the heat pipes where it needs to be, all boxes of tubes, or individual tubes need to be turned up-side-down, and then returned to the upright orientation. In addition, before installing the tube and heat pipe, they should be shaken up and down a couple of times (heat pipe at top) to ensure the powder has all returned to the bottom.

#### 2.9.2. Heat Pipe and Evacuated Tube Insertion

- The heat pipe will already be inserted fully into the evacuated tube.
- If an evacuated tube is damaged for any reason (e.g. knocked heavily or dropped), it will need to be replaced. Either use another tube with heat pipe already inserted, or if a plain evacuated tube spare is being used, carefully remove the heat pipe from the broken tube and insert into the new tube. This should be done with care, holding the heat pipe close to the tube opening and inserting by making a short push and twisting action. Never throw heat pipes away, as they are very sturdy and will not be damaged even if the tube has been. They can be kept as spares, or inserted into plain spare evacuated tubes.
- While holding the spring plate in place, pull the heat pipe out of the evacuated tube by about 3" / 8cm. Using the heat transfer paste, form a thin layer over the heat pipe head (not the top round end).

*Note:* The powder content of the thermal paste may have settled during storage and freight – in order to ensure optimal thermal conductivity, it is advisable to sit the tube (cap

## PART 2: INSTALLATION (CONTINUED)

downward) in a glass of warm water (particularly in cool weather) to allow the powder to mix through. This will also allow the paste to become thinner, making application and heat pipe insertion easier.

- d) Lubricate the top outer surface of the evacuated tube with a small amount of water. This facilitates easy insertion past the manifold rubber ring seal. A small pump spray bottle is the best method for carrying and applying the water.

### ⚠ NOTICE

#### DO NOT SPRAY WATER INTO THE EVACUATED TUBE

- e) While ensuring the metal spring plate is sitting in the mouth of the evacuated tube, firmly hold the evacuated tube, guiding the heat pipe tip in past the manifold rubber seal and into the heat pipe port. Ensure that the heat pipes are at the TOP of the evacuated tube, and therefore aligned correctly with the heat pipe port.
- f) Using a slight (1/8th turn) left and right twisting action, push the evacuated tube up into the manifold. The neck of the evacuated tube will push against the spring at the base of the heat pipe tip, forcing it fully into the port.
- g) The heat pipe and evacuated tube are fully inserted, once the black coating of the evacuated tube has disappeared up into the manifold (no clear glass visible) and the bottom of the tube sits correctly in the bottom track.
- h) As each tube is inserted or alternatively, once all tubes have been inserted, secure the tubes to the bottom track using the stainless steel clips as follows:
  - Step 1) Line up the clip with the hook on the bottom track and push down over the rubber cap while favoring one side until a "click" sound is heard.
  - Step 2) While centralizing the clip over the top of the rubber cap, push down the other side until it too "clicks" into position.
  - Step 3) Check to ensure both sides are correctly clipped over the hooks.
- i) The clip can be removed by using a small screwdriver or needle nosed pliers to pull each side of the clip down and outward.
- j) As the distance between consecutive tubes is minimal, it may be necessary to push a consecutive tube slightly off to the side while attaching the clip to allow enough room to operate.

### 2.9.3. Post Installation Cleaning

- a) Clean each evacuated tube with a liquid glass cleaner and cloth/paper.

## 2.10 POST INSTALLATION

### 2.10.1. Collector Operation

- a) After installing all the tubes, and given good sunlight, the solar collector will begin to produce heat after a 5-10 min. "warm up" period. Check the Delta-T controller and pump for correct operation and adjust settings as required.

## PART 2: INSTALLATION (CONTINUED)

### 2.11 PRECAUTIONS

#### **⚠ WARNING**

**Always wear safety glasses when handling evacuated tubes  
 Wear leather gloves when handling metal components  
 Wear thick leather gloves if handling hot heat pipes  
 Adhere to safety regulations regarding working on roofs (or at a height)**

#### 2.11.1. Metallic Components

- a) Always wear leather protective gloves when handling solar collector components. All efforts have been made to make the metal components safe to handle, but there may still be some sharp edges.

#### 2.11.2. Evacuated tubes

- a) Be careful when handling the evacuated tubes, as they will break if knocked heavily or dropped.
- b) If exposed to sunlight and therefore hot (have internal pressure built up), the tubes may explode rather than implode if knocked and broken. This is a rare occurrence, but nevertheless safety precautions should be taken.

Safety glasses and gloves should always be worn when handling the evacuated tubes.

#### 2.11.3. High Temperatures

- a) With the heat pipe installed in the evacuated tube, and good sunlight, the heat pipe tip can reach temperatures in excess of 392°F / 200°C. At this temperature touching the heat pipe will result in serious burns, so thick leather gloves must be worn when handling hot tubes and heat pipes.
- b) In an installed fully plumbed system, if the pump is stopped during good sunlight the collector header and plumbing pipe close to the manifold can easily reach temperatures in excess of 320°F / 160°C, and therefore caution should be taken when handling such components.

#### 2.11.4. Broken Glass

- a) If the evacuated tubes are struck by a hard object with sufficient force (e.g. branch falling on roof), they may break. During installation consideration should be taken as to the possible path any broken glass may take. Where possible protection should be implemented to prevent broken glass from reaching ground level where somebody could walk on it (e.g. guttering on roof).

The installer should notify the home owner of the location of the solar collector and the possible vicinity of broken glass in the event of an extreme storm or falling object on the collector.

#### 2.11.5. Avoid Water Damage

- a) For any part of the plumbing system that is contained inside the building, consider issues associated with leakage and subsequent water damage.
- b) Always run drain lines from drain/cock valves and overflow pipes to a safe drainage point.
- c) Place tray underneath tanks to contain any leaking water.
- d) Take care to check all connections for leaking before final commissioning of the system.

## PART 3: MAINTENANCE

Under normal conditions the solar collector is maintenance free. Other system components such as the pump, glycol liquid (if used) may require periodic inspection and changing/maintenance. Please

## PART 3: MAINTENANCE (CONTINUED)

refer to the documentation provided by the component manufacturer of these other components.

### **⚠ WARNING**

**SYSTEM INSPECTION, MAINTENANCE OR REPAIR SHOULD ONLY BE COMPLETED BY AUTHORIZED PERSONS. THE SOLAR COLLECTOR WARRANTY COVERAGE MAY BE VOID IF NON-AUTHORIZED PERSONS ATTEMPT TO MAINTAIN OR REPAIR THE SOLAR COLLECTOR OR ASSOCIATED COMPONENTS.**

***NOTE: The following basic maintenance may be completed by the HOME OWNER***

#### 3.1. CLEANING

- a) Regular rain should keep the evacuated tubes clean, but if particularly dirty they may be washed with a soft cloth and warm, soapy water or glass cleaning solution but **ONLY** if the solar collector is located in a position which does require climbing onto the roof, use of step-ladder or otherwise potentially dangerous location. If the tubes are not easily and safely accessible, high-pressure water spray is also effective.
- b) If cleaning is required and the above outlined methods are not suitable, the company that supplied and installed the solar collector should be contacted to complete such cleaning.

#### 3.2. LEAVES

- a) During autumn, leaves may accumulate between or beneath the tubes. Please remove these leaves regularly to ensure optimal performance and to prevent a fire hazard. (The solar collector will not cause the ignition of flammable materials). Such cleaning may only be completed by the homeowner if the tubes are easily and safely accessible.

***The following maintenance may ONLY be completed by AUTHORIZED PERSONS***

#### 3.3. BROKEN TUBE

- a) If a tube is broken it should be replaced as soon as possible to maintain maximum collector performance.
- b) The system will still operate normally and safely even with a tube broken.
- c) Any broken glass should be cleared away to prevent injury.
- d) To replace a tube:
  - Remove the tube clip(s), slide broken tube out and carefully pick up any glass pieces.

### **⚠ WARNING**

**Protective gloves must be worn when handling broken glass.**

- When removing the broken tube, the rubber ring in the manifold casing may pop out. Just return this ring into place before inserting the new tube.
- Avoid touching the glass wool insulation with bare hands, as it can cause mild skin irritation.
- If the heat pipe is not easily removed (commonly the case), it can be left in place and a new evacuated tube inserted, guiding the heat pipe down the groove between the evacuated tube inner wall and heat transfer fin. - If the heat pipe is easily removed, the easiest option is to replace the heat pipe and evacuated completely.

## PART 3: MAINTENANCE (CONTINUED)

### 3.4. INSULATION

- a) The plumbing pipes running to and from the collector should be heavily insulated. This insulation foam should be checked periodically (at least once every 3 years) for damage.
- b) For any insulation that is exposed to sunlight, ensure any protective cover/wrap/foil is in good condition, replacing as required.

### 3.5. DRAINING THE COLLECTOR

- a) Draining of the manifold may be required if maintaining the system or in preparation for extremely cold conditions (extended snow cover). In order to drain the collector of fresh water (direct flow system):

Step 1. Turn off the mains water supply to the solar storage tank.

Step 2. If the storage tank or other system components are being concurrently drained, refer to their instruction manuals for details. If storage tank is not being drained, isolate piping to and from the solar collector (isolation valves should already be installed), and immediately open drain valves on both lines (or undo fittings). Never leave the isolation valves in the off position while the collector is full of water and exposed to sunlight as the water will heat cause a pressure increase which may rupture fittings/connections. **In good weather the water may be hot or have built up pressure, so take care when opening the drain valve.**

Step 2. Allow the manifold to sit in a vented state for 5-10min to allow the manifold to boil dry (may need longer in poor weather).

Step 4. Always leave one drain valve or fitting open, otherwise the system may build up pressure when it heats.

- b) For draining of other types of systems, you must refer to specific instructions for the system used.

### 3.6. OTHER COMPONENTS

- a) Other parts of the system such as the pump and storage tank (electric or gas water heater) should be serviced/ inspected according to their manufacturer's own maintenance guidelines.

### 3.7. FREEZING

- a) During extended sub-zero periods with concurrent pump/controller failure or power outage, a direct flow (water) system may suffer from freeze related damage, indicated by no pump flow due to pipe blockage, or in most cases leaking due to a split pipe.
- b) The most likely area of freeze damage is exposed copper piping, particularly near elbows or connections. Once the system thaws, leaks will indicate any areas of damage which require replacement.
- c) To repair, isolate flow to the collector or drain the system and repair/replace any damaged piping, then recommission the system.
- d) If freezing is a regular occurrence, consider installing a battery power backup system to ensure continued operation of the pump and controller during a power outage. To provide complete protection the system may need to be upgraded to a closed loop glycol system.

## PART 4: TROUBLESHOOTING

Those inspection items with an (H) in front may be completed by the home-owner, but only if such investigation is clearly both SAFE and EASY. Any information obtained during an inspection can then be relayed onto the company who supplied and installed the system. Any other system troubleshooting, system adjustments, or repairs may only be completed by authorized persons.

### 4.1. NO HOT WATER

- a) If there is no hot water, it will generally be related to the gas or electric heating system, and not the solar collector. The collector simply pre-heats water, with final boosting completed by the electric element or gas back-up system. For a retrofitted solar system, please contact the manufacturer/installer of your gas/electric water heater. For a new solar water heating system, please contact the company that supplied and installed the system.

### 4.2. REDUCED SOLAR CONTRIBUTION

- a) Solar contribution to your heating is directly related to the amount of solar radiation and the volume of hot water used. During the winter, and periods of rainy, or particularly overcast weather, the amount of energy produced by the solar collector will be greatly reduced.
- b) As a general rule, the solar collector will have been sized to provide close to 100% of your summer hot water needs, which, depending on your location and hot water usage patterns, may result in between 40% - 70% of your annual hot water energy needs. During the winter, increased cloud cover and reduced solar radiation levels may result in solar contribution as low as 20%. This is normal.
- c) If, given similar environmental conditions, you feel that the solar contribution (as indicated by energy savings) has considerably reduced, there may be a problem with your solar heating system. This may be due to an incorrectly configured controller, pump malfunction or problem with the boosting system. In such cases please contact the company who supplied and installed the system.

#### Inspection

1. Does the circulation pump appear to be operating? In good sunny weather the circulator pump should come on for 1-2 minutes once every 3-5 minutes. The pump may run very quietly, and so you may need to touch the pump or piping running to and from with a solid object to feel for motor operation (slight vibration).



#### **⚠ CAUTION**

**DO NOT USE FINGERS AS IT MAY BE HOT!!**

2. Are all the evacuated tubes intact? If a tube has been damaged or discolored it will reduce the system performance and should be replaced. If a tube is damaged, do not attempt to remove it; contact the company who supplied and installed the system.
3. Are there any apparent leaks in the plumbing to and from the collector? Any water trails down the roof, or around the storage tank?

### 4.3. REGULAR WATER DUMPING

- a) During normal daily hot water use, if the temperature relief valve on the tank or collector is regularly dumping hot water (more than just a dribble), it may indicate a problem with the system.

## PART 4: TROUBLESHOOTING (CONTINUED)

### Possible Causes:

1. The system has been sized incorrectly (oversized). This will be most apparent in the summer months, when solar radiation levels are high.
2. A problem exists with the electric heating thermostat (Electric boosting only).

### Inspection

To test the system, run the hot water tap in the bathroom or kitchen for 5 minutes to release some heat from the system.



### ⚠ WARNING

**THE WATER WILL BE HOT, SO USE CAUTION**

If after this period, the tank or collector is still regularly dumping hot water, it indicates a problem. Please contact the company who supplied and installed the system to organize a service call.

## PART 5. INSTALLATION CHECKLIST

The following list is a guide only. Specific items will depend on the nature of the installation.

1	Collector faces as close as possible to due North/South.	Y	N
2	Manifold is not significantly shaded throughout the day.	Y	N
3	Manifold is not likely to be struck by falling objects such as branches, falling fruit, or other nearby objects	Y	N
4	Collector is installed at an angle of between 20° – 80°, preferably at latitude angle.	Y	N
5	In areas prone to large hail (> 3/4" / 20mm), collector is installed at an angle of 40° or greater.	Y	N
6	Frame is secured to structurally sound roof/wall.	Y	N
7	Plumbing is leak free.	Y	N
8	Plumbing pipe runs are well insulated.	Y	N
9	Insulation above roof level is protected against sunlight with foil wrap or equivalent.	Y	N
10	Controller is configured correctly with freeze setting on (if required).	Y	N
11	System is fitted with pressure relief valve on the collector outlet and/or storage tank.	Y	N
12	Pressure relief valve will dump only onto high temperature resistant material and will not pose a danger of scalding people.	Y	N
13	Pump, controller and all electrical connections are protected from water ingress.	Y	N
14	Evacuated tubes have been cleaned.	Y	N
15	Installation record form has been given to customer and basic operation explained.	Y	N
16	Functional checks for controller and pump have been completed.	Y	N
17	Water quality has been checked (if applicable).	Y	N

All items should be ticked **Y** for the installation to be considered completed and satisfactory.

# APPENDIX A

## Solar Collector Standard Frame Kit

Part #: FR-XX-STANDARD

This frame is suitable for flush installation on a pitched roof. If installing on a low pitched roof, or flat roof, an additional frame kit is required which will complement the components already contained in this standard frame kit.

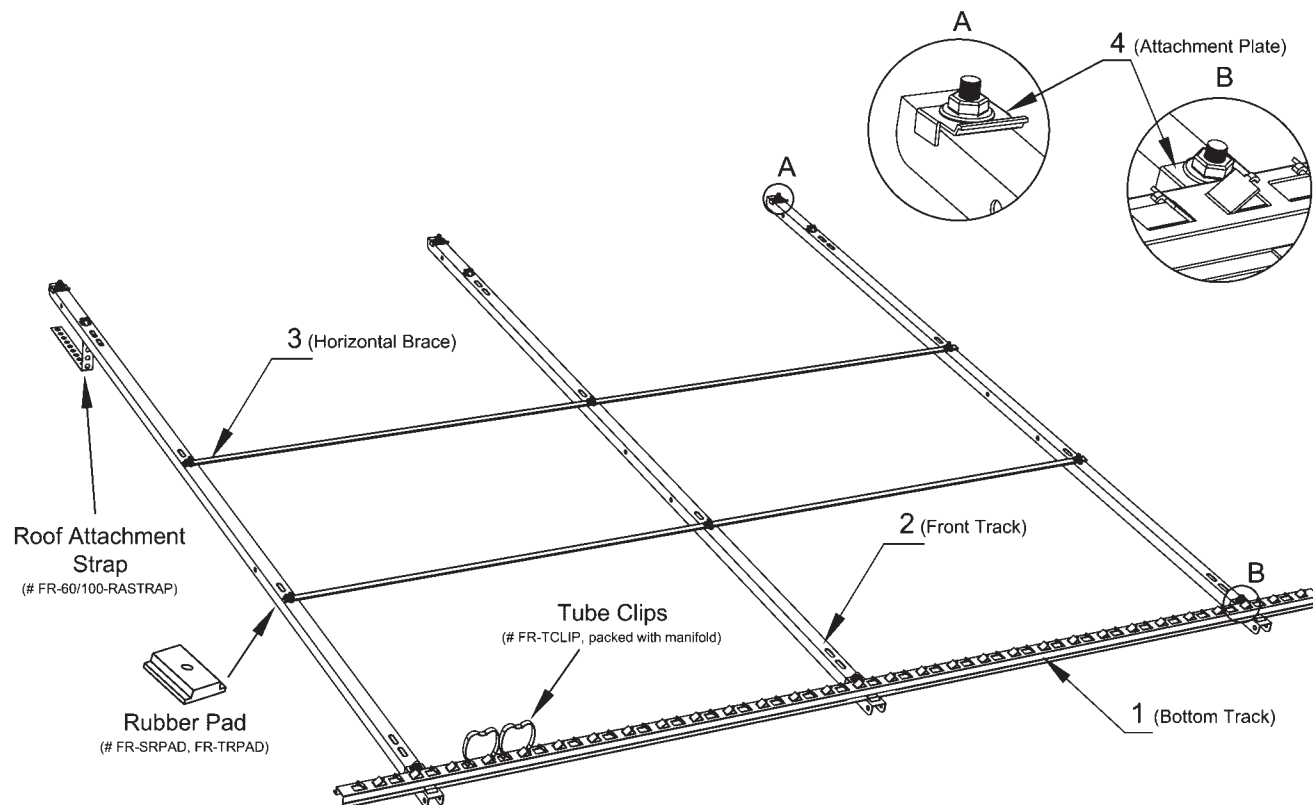

### Roof Attachment Options (Components Supplied Separately)

Tiled Roof – *Roof Attachment Straps*

Corrugated Iron Roof – *Standard Rubber Pads*

Asphalt Shingle Roof – *Extra Thick Rubber Pads*

or

Low, Mid, High or Fixed Angle Frame Kit

### Frame Packing List

Part #	Component Quantities
	30 Tube
1. FR-BTRACK-XX	1
2. FR-FTRACK-XX	3
3. FR-HBRACE	2
4. FR-APLATE	6
5. FR-BOLT-M8x20	12
6. FR-NUT-M8	12
7. FR-WASH-B	6
8. FR-SWASH	12
9. FR-WASH-S	6
10. FR-NLOCK	12

Nuts and bolts are already attached to the appropriate components.

### **⚠ WARNING**

#### SAFETY CONSIDERATIONS

- Wear gloves when handling frame components
- If installing on corrugated iron roofs, always use rubber pads, thus preventing direct contact between galvanized iron and stainless steel frame.
- Ensure roof attachment points are structurally sound
- Follow relevant safety regulations regarding working on roofs

# APPENDIX B

## Solar Collector Low Angle Frame Kit

Part #: FR-XX-LOW-RFOOT/RTRACK

The components contained in this package combine with the standard frame to form the complete frame assembly shown below.

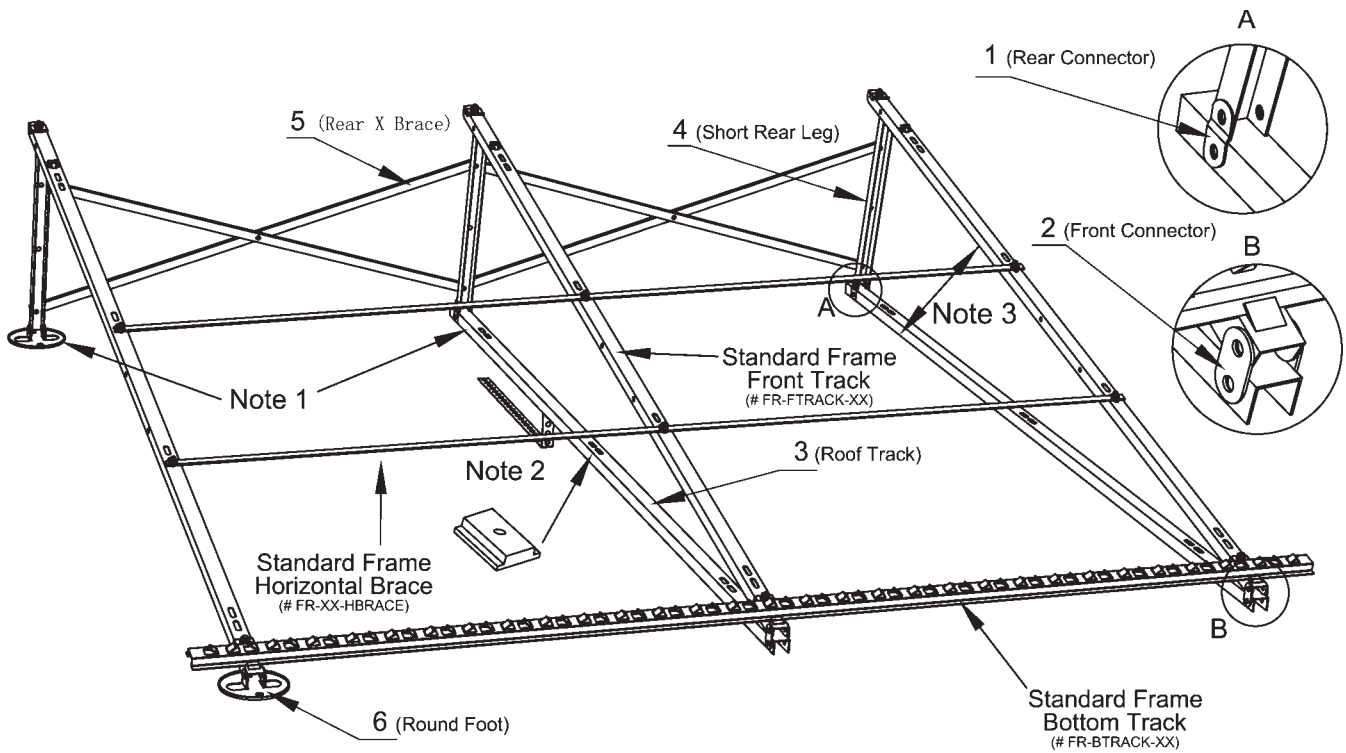

**Notes:**

1. There are two mounting options, ROUND FEET or ROOF TRACKS.
2. When using the Roof Tracks, attachment to the roof may be via roof attachment straps (# FR60/100-RASTRAP) or rubber pads (# FR-SRPAD, FR-TRPAD) depending on roof surface.
3. ROUND FEET provide adjustable angle of 11-13 deg. ROOF TRACKS provide a set angle of 12 deg.

Nuts and bolts are already attached to the appropriate components.

### Frame Packing List

Part #	Component Quantities	
	30 Tube	
	FEET	R. TRACK
1. FR-RCON	6	
2. FR-FCON	6	
3. FR-RTRACK	-	3
4. SR-SRLEG	3	
5. FR-RXB-MID-XX	4	
6. FR-RFOOT	-	
7. FR-BOLT-M8x50	15	
8. FR-BOLT-M8x40	4	
9. FR-BOLT-M8x20	4	
10. FR-NUT-M8	23	
11. FR-SWASH	23	
12. FR-WASH-S	38	
13. FR-WASH-B	-	
14. FR-NLOCK	8	
15. FR-SPAN-12/14	1	

**⚠ WARNING**

**SAFETY CONSIDERATIONS**

- Wear gloves when handling frame components
- If installing on galvanized iron roofs, always use rubber pads, thus preventing direct contact between galvanized iron and stainless steel frame.
- Ensure roof attachment points are structurally sound
- Follow relevant safety regulations regarding working on roofs

# APPENDIX C

## Solar Collector Mid Angle Frame Kit

Part #: FR-XX-MID-RFOOT/RTRACK

The components contained in this package combine with the standard frame to form the complete frame assembly shown below.

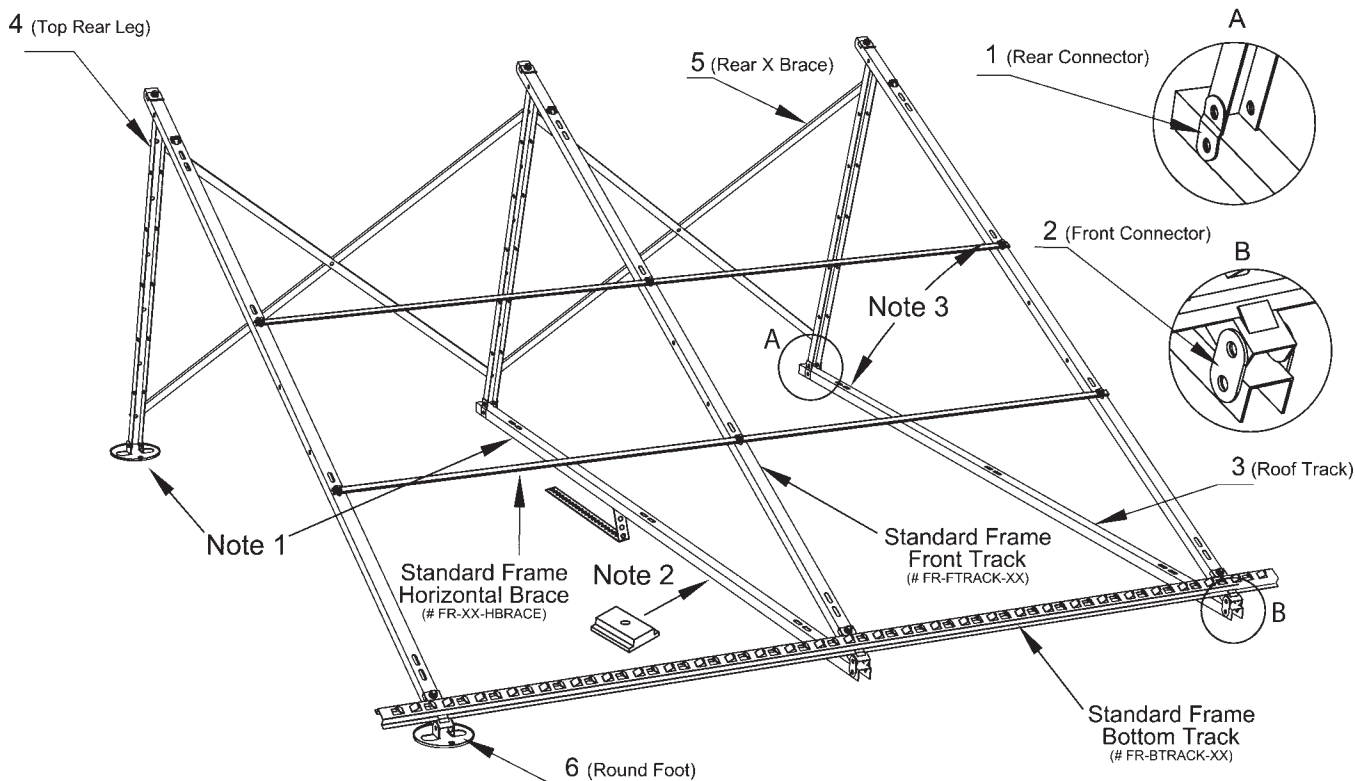

**Notes:**

1. There are two mounting options, ROUND FEET or ROOF TRACKS.
2. When using the Roof Tracks, attachment to the roof may be via roof attachment straps (# FR60/100-RASTRAP) or rubber pads (# FR-SRPAD, FR-TRPAD) depending on roof surface.
3. ROUND FEET provide adjustable angle of 21-28 deg. ROOF TRACKS provide a set angle of 27 deg.

**Frame Packing List**

Part #	Component Quantities	
	30 Tube	
	FEET	R. TRACK
1. FR-RCON	6	
2. FR-FCON	6	
3. FR-RTRACK	–	3
4. SR-TRLEG	3	
5. FR-RXB-MID-XX	4	
6. FR-RFOOT	–	
7. FR-BOLT-M8x50	15	
8. FR-BOLT-M8x40	4	
9. FR-BOLT-M8x20	4	
10. FR-NUT-M8	23	
11. FR-SWASH	23	
12. FR-WASH-S	38	
13. FR-WASH-B	–	
14. FR-NLOCK	8	
15. FR-SPAN-12/14	1	

Nuts and bolts are already attached to the appropriate components.

**WARNING**

**SAFETY CONSIDERATIONS**

- Wear gloves when handling frame components
- Feet must be bolted to ground
- Ensure attachment points are structurally sound
- Follow relevant safety regulations regarding working on roofs

# APPENDIX D

## Solar Collector High Angle Frame Kit

Part #: FR-XX-HIGH

The components contained in this package combine with the standard frame to form the complete frame assembly shown below.

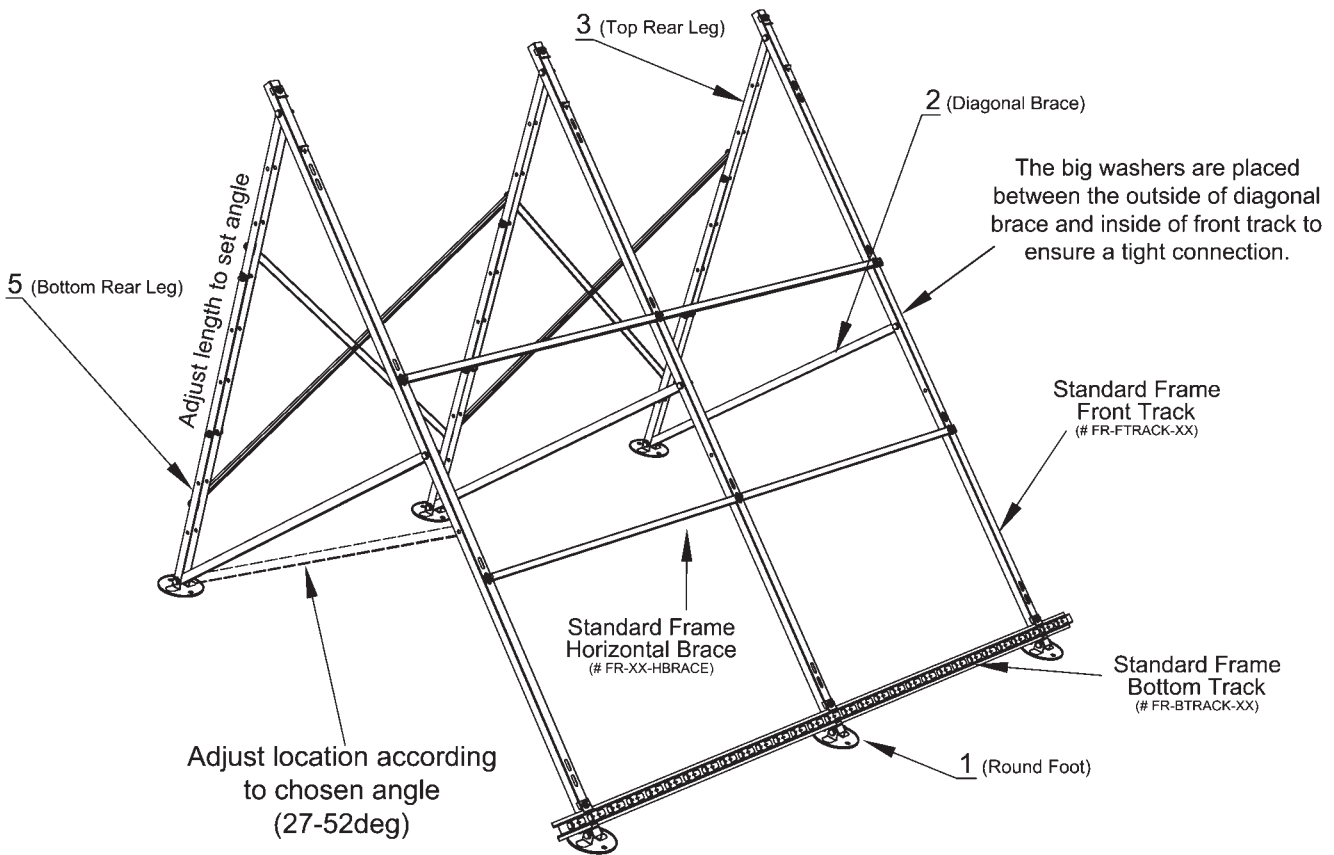

Frame Packing List

Part #	Component Quantities
	30 Tube
1. FR-RFOOT	6
2. FR-DBRACE	3
3. SR-TRLEG	3
4. FR-RXB-HIGH-XX	4
5. FR-BRLEG	3
6. FR-BOLT-M8x50	18
7. FR-BOLT-M8x40	4
8. FR-BOLT-M8x20	4
9. FR-NUT-M8	26
10. FR-SWASH	26
11. FR-WASH-S	44
12. FR-WASH-B	12
13. FR-NLOCK	8
14. FR-SPAN-12/14	1

Nuts and bolts are already attached to the appropriate components.

### **WARNING**

#### **SAFETY CONSIDERATIONS**

- Wear gloves when handling frame components
- Feet must be bolted to ground
- Ensure attachment points are structurally sound
- Follow relevant safety regulations regarding working on roofs

## APPENDIX E

## Solar Collector Wall Mounting Diagram

Majority of collector weight and wind stress load is on these top points, so attachment bolts/screws and wall structure must be of suitable strength.

Need to remove corner of attachment plate to allow round foot to fit in place.

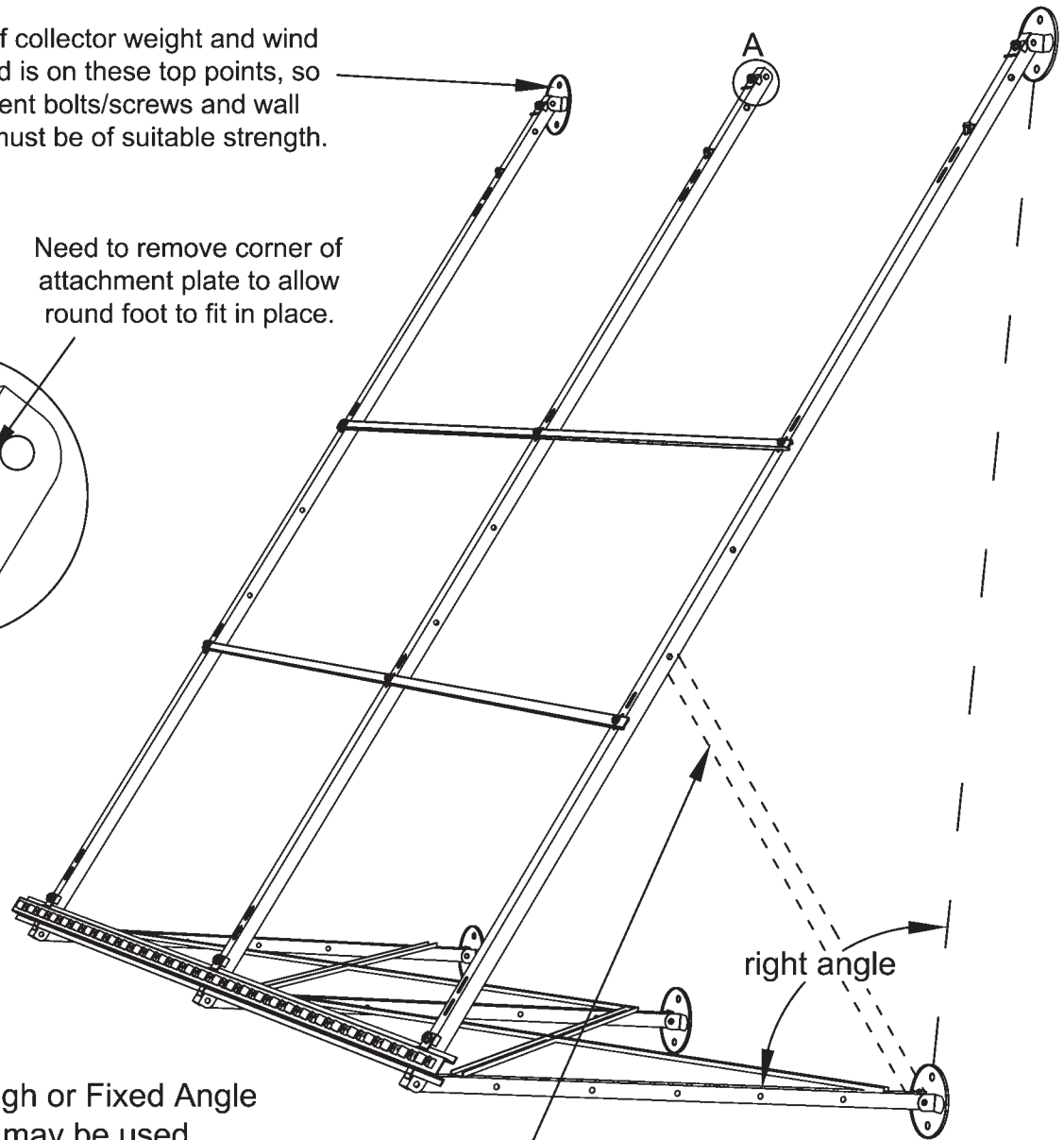
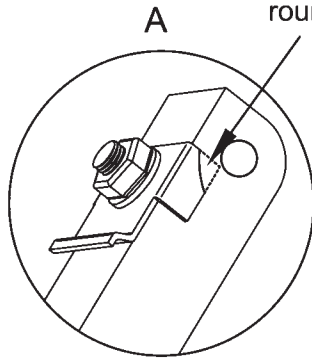

Low, Mid, High or Fixed Angle Frames may be used.

Diagonal Brace should be installed when using high angle frame.

## APPENDIX F

## Frame Dimensions &amp; Spacing

When using a high angle frame kit on a flat roof (common for commercial applications), the spacing of the frame feet and collectors needs to be known. This depends on the angle at which the collector is installed. The following tables provide this information.

## FEET SPACING AND FRAME HEIGHT

Angle	D	H
52°	55.35"	60.6"
45°	61.6"	54.7"
39°	66.45"	48.5"
33°	70.55"	42.3"
28°	67.9" *	36.8"

\* Using bottom hole on front track for diagonal brace connection.

## LATERAL FEET SPACING

Size	S
30 tubes	37.2"

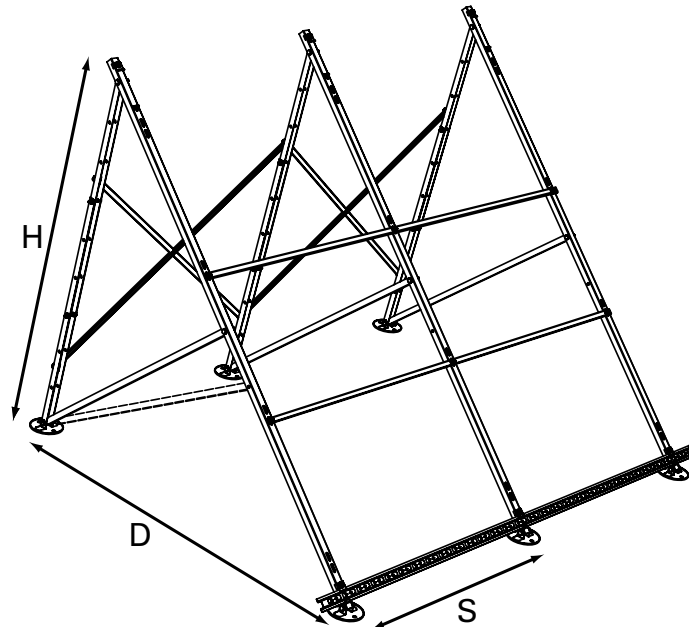

In all cases the standard location for the front tracks is beneath the second tube from each end (For 30 tube collector the third leg is located in a central position). The standard distance between the rear X brace attachment bolts on the rear legs is 23.6" (4 holes). Choosing holes further apart, or closer together for the rear X brace attachment points on the rear legs will bring the feet closer together, or splay them further apart, respectively. Starting in 2008, rear X braces come with a series of elongated holes at both ends, allowing the location of the legs to be adjusted slightly to better adapt to roof surfaces.

## SPACING OF CONSECUTIVE COLLECTORS

The distance between two consecutive collectors will depend on whether an End or Rear port manifold is being used. In most cases End port manifolds are used for commercial applications, because issues with air-locks are avoided.

The following values are from round foot centre to centre.

REAR = 6.5" (0.19" gap between manifold ends)

END = 14.4" (Using straight 22Cx22C compression fitting)

Please note that a straight connector (no flexibility) may only be used for two collectors in series. More than 2 collectors in series must have flexible connectors.

## APPENDIX G

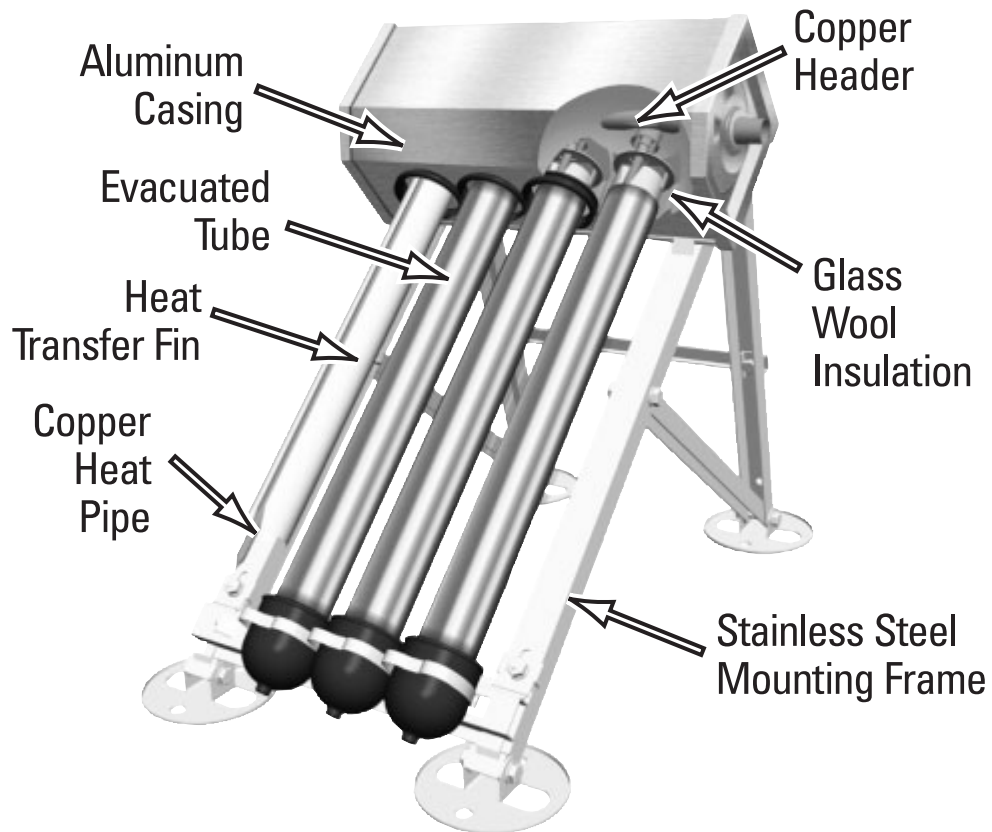

The above picture is a miniature version of the full size solar collector, designed to give a clear representation of the key collector components. Collector design may differ from that shown above.





## HTP, INC. Customer Installation Record Form

the following form should be completed by the installer for you to keep as a record of the installation in case of a warranty claim. After reading the important notes at the bottom of this page, please also sign this document.

Customer's Name:	
Address of Installation:	
Date of Product Installation:	
Installer's Code/Name:	
Product Serial Number(s):	
Comments:	
Installer's Phone Number: <sup>1</sup>	
Signed by Installer:	
Signed by Customer: <sup>2</sup>	

**IMPORTANT NOTES:**

***1. Please only sign if you are happy with the service provided by the installer and the system is working properly. If you are not satisfied, call your HTP, Inc. Sales Representative.***

***2. In the case that the system has any problems, please call the installer. If you are unable to make contact, or are unhappy with the response, please contact your HTP, Inc. Sales Representative.***

*DISTRIBUTOR/DEALER PLEASE INSERT CONTACT DETAILS.*

