

DISCAL air separator

series 551



cert. n° 0003
ISO 9001

01060/07 NA



Function

Air separators are used to continuously remove the air contained in the hydronic circuits of heating and cooling systems. The air discharge capacity of these devices is very high. They are capable of removing automatically all the air present in the system down to micro-bubble level.

The circulation of fully de-aerated water enables the equipment to operate under optimum conditions, free from any noise, corrosion, localised overheating or mechanical damage.

Product range

- Series 551 DISCAL air separator in brass compact with drain _____ Sizes 3/4" sweat; 3/4" NPT female
- Series 551 DISCAL air separator in brass with drain _____ Sizes 3/4" - 1" - 1 1/4" - 1 1/2" - 2" NPT female; 1" - 1 1/4" sweat
- Series 551 DISCAL air separator in steel with flanged connections _____ Sizes 2" ÷ 6" ANSI
- Series NA551 DISCAL air separator in steel with flanged connections designed and built in accordance with Section VIII, Division 1 of the ASME Boiler and Pressure Vessel Code and tagged and registered with the National Board of Boiler and Pressure Vessel Inspector _____ Sizes 2" ÷ 6" ANSI
- Series NA551 DISCAL air separator in steel with threaded connections designed and built in accordance with Section VIII, Division 1 of the ASME Boiler and Pressure Vessel Code and tagged and registered with the National Board of Boiler and Pressure Vessel Inspector _____ Sizes 2" ÷ 4"
- Cod. 561402A Service check valve in brass for easy replacement of expansion tank mounted to bottom drain _____ Size 1/2" NPT x 1/2" NPT

Technical specification

Brass Discal

Materials: - Body: brass
- Int. element (compact version): stainless steel
- Int. element: PA66GF30
- Seal: EPDM

Suitable fluids: water, glycol solution
Max percentage of glycol: 50%
Max working pressure: 150 psi (10 bar)
Temperature range: 32÷250°F (0÷120°C)
Connections: - Main: 3/4" sweat; 3/4" NPT female
3/4" - 1" - 1 1/4" - 1 1/2" - 2" NPT female
1" - 1 1/4" sweat
- Drain: 1/2" NPT female

Steel Discal

Materials: - Body: epoxy resin painted steel
- Int. element: stainless steel
- Drain cock: chrome plated brass
- Seal: EPDM

Suitable fluids: water, glycol solution
Max percentage of glycol: 50%
Max working pressure: 150 psi (10 bar)
Temperature range: 32÷250°F (0÷120°C)
Connections: - Flanged: 2" ÷ 6" ANSI 150 CLASS
- Threaded: 2" ÷ 4"
- Drain: 1" NPT male

Dimensions

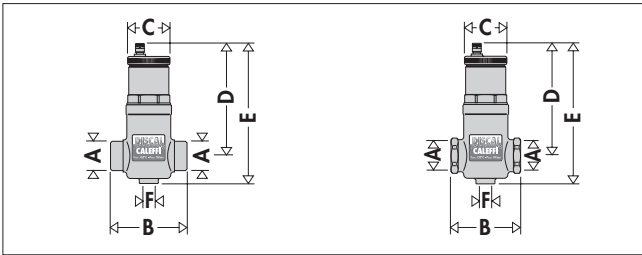

Code	A	B	C	D	E	F	Weight (lb)
551022A	3/4"	3 1/16"	2 3/16"	5 5/8"	6 7/8"	1/2"	2.0
551003A	3/4" swt	3 1/16"	2 3/16"	5 5/8"	6 7/8"	1/2"	2.0

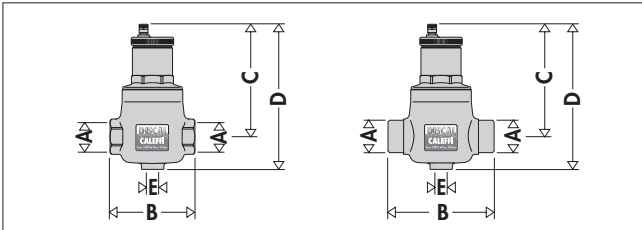

Code	A	B - B'	C	D	E	Weight (lb)
551005A	3/4"	4 5/16"	5 3/4"	7 1/2"	1/2"	3.7
551006A	1"	4 5/16"	5 3/4"	7 1/2"	1/2"	3.7
551007A	1 1/4"	4 7/8"	6 9/16"	8 1/4"	1/2"	4.9
551008A	1 1/2"	4 7/8"	6 9/16"	8 1/4"	1/2"	4.9
551009A	2"	5 1/8"	6 9/16"	8 1/4"	1/2"	4.9
551028A	1" swt	5 1/16"	5 3/4"	7 1/2"	1/2"	3.7
551035A	1 1/4" swt	5 3/16"	6 5/16"	8 1/4"	1/2"	3.7

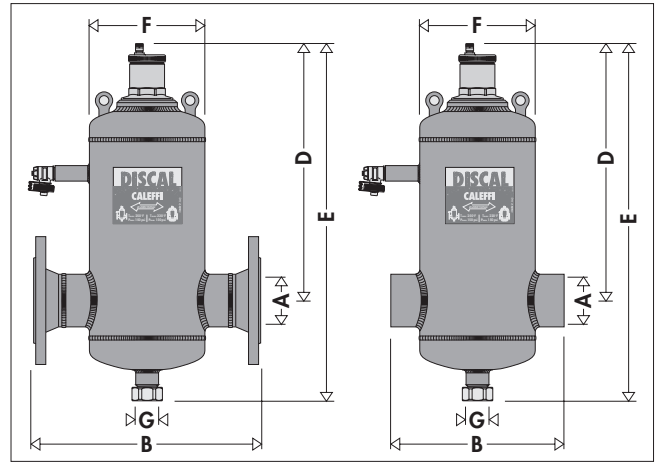

Code	A	B	D	E	F	G	Weight (lb)
551050A	2"	13 3/4"	14 3/4"	19 15/16"	6 5/8"	1"	33.1
551060A	2 1/2"	13 3/4"	14 3/4"	19 15/16"	6 5/8"	1"	34.2
551080A	3"	18 3/8"	17 1/8"	23 7/16"	8 5/8"	1"	61.7
551100A	4"	18 1/2"	17 1/8"	23 7/16"	8 5/8"	1"	66.1
551120A	5"	25	21 7/16"	30 1/2"	12 3/4"	1"	105.8
551150A	6"	25	21 7/16"	30 1/2"	12 3/4"	1"	116.8
NA551050T	2"	10 1/4"	14 3/4"	19 15/16"	6 5/8"	1"	20.5
NA551060T	2 1/2"	10 1/4"	14 3/4"	19 15/16"	6 5/8"	1"	21.0
NA551080T	3"	14 5/8"	17 1/8"	23 7/16"	8 5/8"	1"	44.0
NA551100T	4"	14 5/8"	17 1/8"	23 7/16"	8 5/8"	1"	46.3

Size	2"	2 1/2"	3"	4"	5"	6"
Cap. (gal)	1.8	1.8	4.8	4.8	13.7	13.7

Add prefix NA to flanged code number when ordering ASME tagged and registered with the National Board of Boiler and Pressure Vessel Inspector

The process of air formation

The amount of air which can remain dissolved in a water solution is a function of pressure and temperature.

This relationship is governed by Henry's Law and the graph below demonstrates the physical phenomenon of the air release from water. As an example, at a constant absolute pressure of 30 psi (2 bar), if the water is heated from 65°F (18°C) to 170°F (75°C), the amount of air released by the solution is equal to 1.8 gallons of air per 100 gallons of water.

According to this law it can be seen that the amount of air released increases with temperature rise and pressure reduction. The air comes in the form of micro-bubbles of diameters in the order of tenths of a millimetre.

In heating and cooling systems there are specific points where this process of formation of micro-bubbles takes place continuously: in the boiler and in any device which operates under conditions of cavitation.

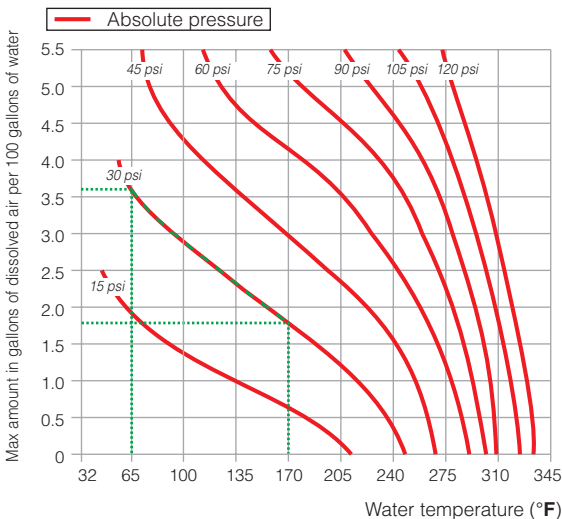

Boiler micro-bubbles

Micro-bubbles are formed continuously on the surface separating the water from the combustion chamber due to the fluid temperature.

This air, carried by the water, collects in the critical points of the circuit from where it must be removed.

Some of this air is reabsorbed in the presence of colder surfaces.

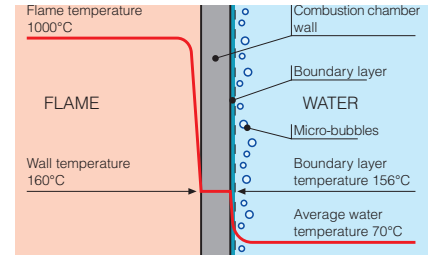

Cavitation and micro-bubbles

Micro-bubbles develop where the fluid velocity is very high with the corresponding reduction in pressure. These points are typically the pump impeller and the regulating valve seating.

These air and vapour micro-bubbles, the formation of which is enhanced in the case of non de-aerated water, may subsequently implode due to the cavitation phenomenon.

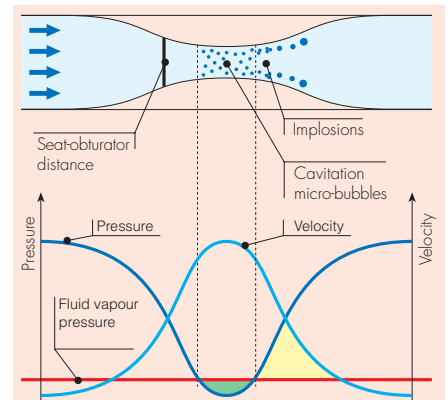

Operating principle

The air separator uses the combined action of several physical principles. The active part consists of an assembly of concentric mesh surfaces. These elements create the whirling movement required to facilitate the release of micro-bubbles and their adhesion to these surfaces.

The bubbles, fusing with each other, increase in volume until the hydrostatic thrust overcomes the adhesion force to the structure. They rise towards the top of the unit from which they are released through a float-operated automatic air release valve.

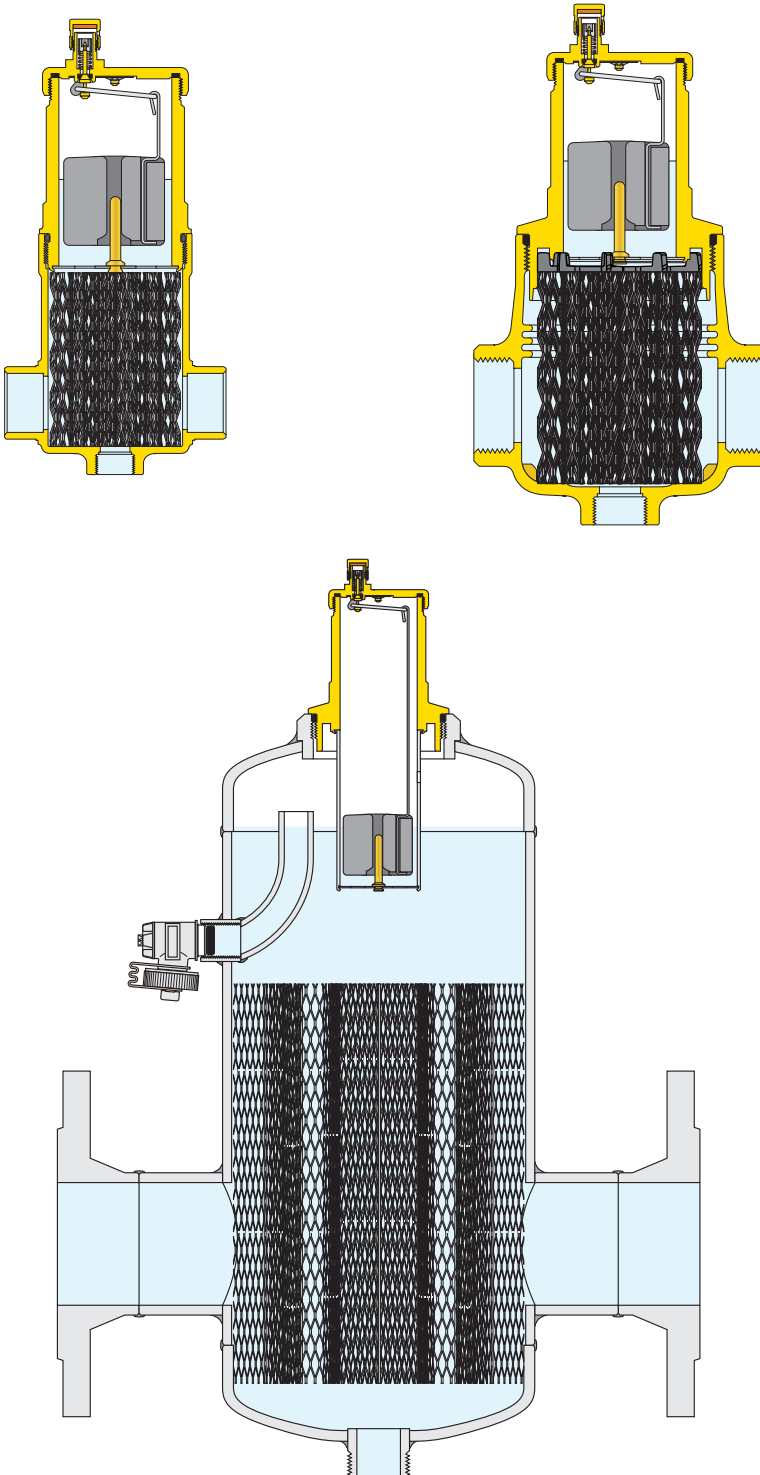
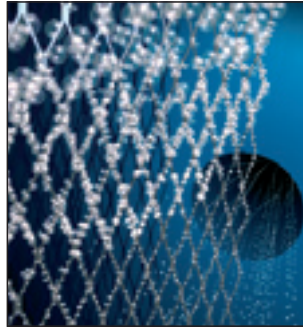

Construction details

DISCAL devices are constructed in such a way as to allow maintenance and cleaning operations to be carried out without having to remove the valve body from the pipework. All valves are fitted with a bottom connection for fitting a drain valve. All internal air release control components are fully accessible in all the models.

The automatic air release valve, located at the top of the units, has a long chamber for the movement of the float. This feature prevents any debris present in the water from reaching the sealing seat.

- The moving parts that control the air venting are accessed simply by removing the upper cover.

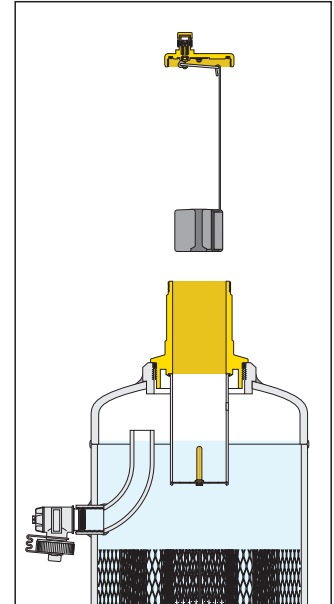
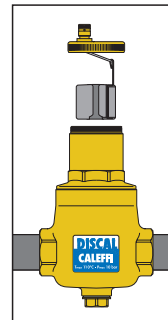

- When cleaning, simply unscrew the portion of the body containing the automatic air vent valve.

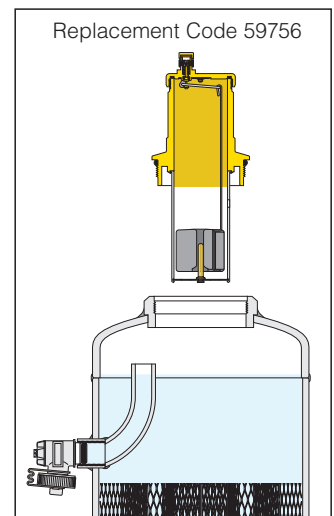
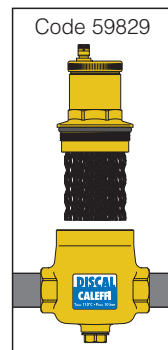

Models are fitted with a further cock to drain large amounts of air when filling the circuit and to remove any debris present above the water level.

Hydronic characteristics

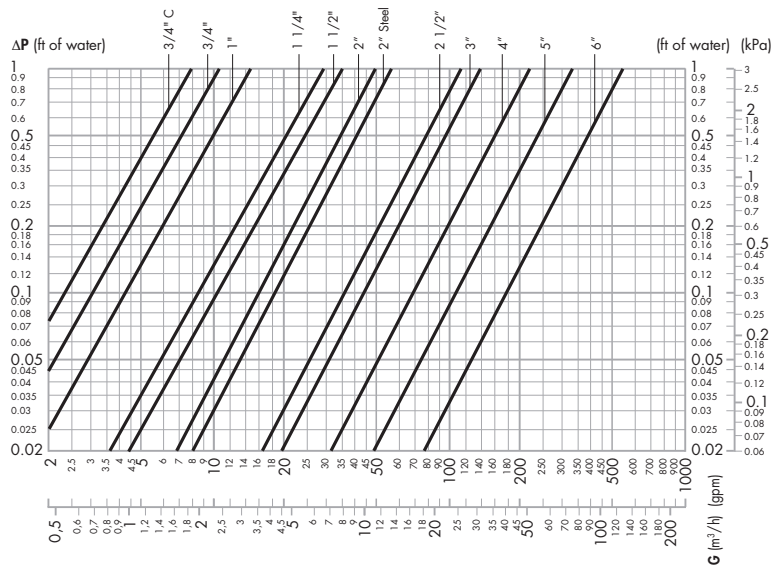

The fluid velocity at connections for Discal 551 series air separators is recommended to not exceed 10.0 f/s. Above this speed, heavy internal turbulence and noise can occur and air elimination efficiency begins to fall measurably. Optimal air elimination performance occurs at fluid velocities of 4.2 f/s or less. See the flow capacity chart.

		FLOW CAPACITY												
		BRASS					STEEL							
		Size	3/4" C	3/4"	1"	1 1/4"	1 1/2"	2"	2"	2 1/2"	3"	4"	5"	6"
Optimal (≤4.2 f/s)	GPM	6.0	8.0	9.3	15.3	23.9	36.1	37.3	63.0	95	149	259	380	
	m ³ /h	1.4	1.8	2.1	3.5	5.4	8.2	8.5	14.3	21.7	33.9	58.8	86.2	
Max. (10.0 f/s)	GPM	14.3	19.0	22.1	36.4	56.8	86.0	88.8	150.1	227.4	355.3	616.4	903.6	
	m ³ /h	3.2	4.3	5.0	8.3	12.9	19.5	20.2	34.1	51.6	80.7	140.0	205.2	
Cv		14	19	21	43	51	78	86	179	211	345	520	809	

Installation

DISCAL units may be used in heating or cooling systems, to ensure the progressive removal of air which is continuously formed. The units should preferably be installed after the boiler and on the pump suction side, as these are the points where the formation of micro-bubbles is greatest. DISCAL air separators must be installed vertically. In installation conditions where inspection is not possible, it is recommended that the venting valve cap is replaced by a Caleffi Code nr. 59681 hygroscopic safety vent. The simple replacement cap part number is 59119.

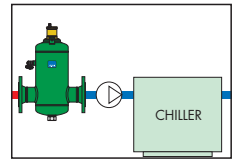
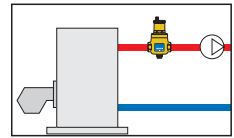
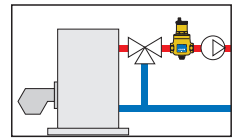

Accessories



Check valve code 561402A for expansion tanks. 1/2" NPT connections.



Hygroscopic safety vent code 59681.



Small anti-vacuum valve code 562100.

SPECIFICATION SUMMARIES

DISCAL Series 551 - Compact

Air separator in brass. Connections 3/4" F threads or 3/4" sweat. Bottom 1/2" F for drain. Brass body. EPDM seal. Internal mesh element of stainless steel, removable for cleaning operations. Maximum working pressure, 150 psi (10 bar). Temperature range 32 to 250°F (0 to 120°C). Glycol maximum 50%.

DISCAL Series 551

Air separator in brass. Threaded connections from 3/4" F to 2" F. Bottom connection 1/2" F for drain. Sweat connections 1" (1" and 1 1/4"). Brass body. EPDM seal. Internal mesh element of PA66G30, removable for cleaning operations. Maximum working pressure, 150 psi (10 bar). Temperature range 32 to 250°F (0 to 120°C). Glycol maximum 50%.

DISCAL Series 551*

Air separator in steel. Bottom male 1" NPT for drain. Flanged 150 CLASS ANSI connections from 2" to 6". Body of epoxy resin painted steel. EPDM seal. Internal mesh element of stainless steel. Maximum working pressure, 150 psi (10 bar). Temperature range 32 to 250°F (0 to 120°C). Glycol maximum 50%.

DISCAL Series 551*

Air separator in steel. Bottom male 1" NPT for drain. Threaded connections from 2" M to 4" M. Body of epoxy resin painted steel. EPDM seal. Internal mesh element of stainless steel. Maximum working pressure, 150 psi (10 bar). Temperature range 32 to 250°F (0 to 120°C). Glycol maximum 50%.

* Designed and built in accordance with Section VIII, Division 1 of the **ASME Boiler and Pressure Vessel Code**.
Optional: Tagged and Registered with the National Board of Boiler and Pressure Vessel Inspectors.

We reserve the right to change our products and their relevant technical data, contained in this publication, at any time and without prior notice.



Caleffi North America, Inc.
 9850 South 54th Street / Milwaukee, WI 53132
 Tel: 414.421.1000 / Fax: 414.421.2878 / www.caleffi.us
 © Copyright 2007 Caleffi North America, Inc.