

PVC Venting Addendum

# RIVA Plus

WALL HUNG GAS BOILER FOR  
CENTRAL HEATING SUPPLY

# Biasi Riva Plus PVC venting accessories

Part #: RI 10999.0912

Trade Price: \$140.00

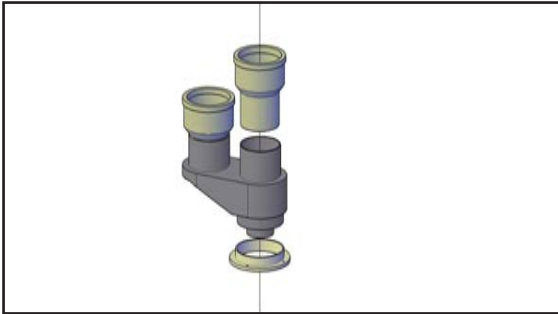

PVC venting adapter: This adapter is required to allow the connection of PVC to the boiler. Adapter mounts to the concentric connection on the top of the boiler and splits to a separate connection for intake and exhaust air. No matter what termination you intend to use this adapter kit is required.

Part #: RI 116035

Trade Price: \$180.00

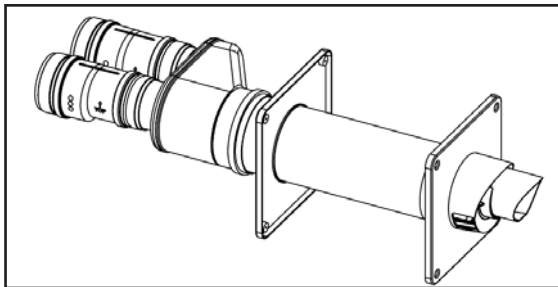

PVC concentric termination: This termination allows you to exhaust gases and take in fresh air through one hole in the side of the building. Two PVC pipes connect to the back of the termination via a gasket connection to provide a clean and finished look on the outside of the building.

Part #: RI 116030

Trade Price: \$215.00

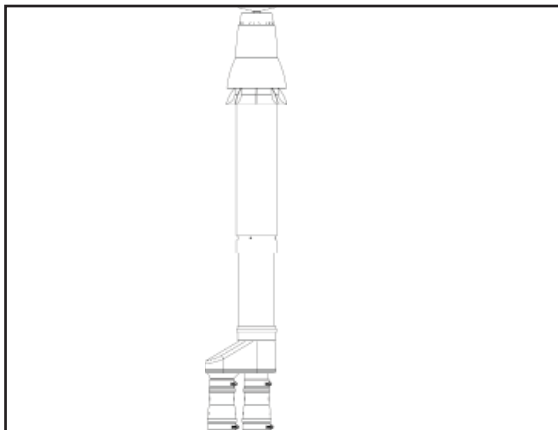

PVC concentric vertical termination: This termination allows you to exhaust gases and take in fresh air through one hole in the roof of the building. Two PVC pipes connect to the bottom of the termination via a gasket connection to provide a clean and finished look on the outside of the building. Flashing kits are available for both flat roofs as well as pitched roofs.

## Site Constructed Vent Termination

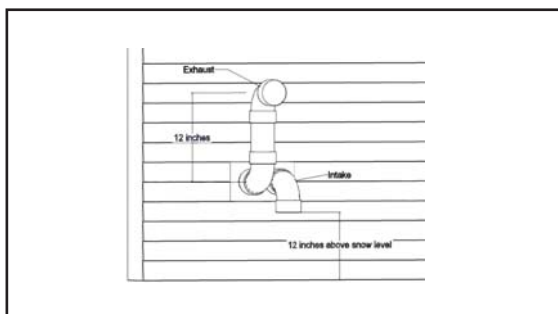

PVC separate venting termination: The contractor terminates the venting outside the building using PVC pipe on hand. Using mesh screens that are supplied with the boiler adapter and adding three elbows and a short length of 3" PVC pipe the contractor can make a simple vent termination.

# PVC vent requirements

All piping that is used to vent the Riva boiler must conform to the standards listed below.

Parts	Material	United States	Canada
Exhaust and Intake Piping	PVC	ANSI/ASTM D1785	ULC S636
	CPVC	ANSI/ASTM DF441	
Pipe Cement / Primer	PVC	ANSI/ASTM D2564	
	CPVC	ANSI/ASTM F493	

It is not permitted to use a cellular foam core pipe for venting the Riva boiler. All intake piping can be constructed of PVC pipe. The first 8 feet of exhaust pipe must be CPVC pipe. After that point it is permissible to assemble the rest of the vent in PVC.

#### Canadian Installations:

- PVC/CPVC vent pipe must be listed to ULC S636. Pipe, fittings, and cements are certified as a system and must be installed as such. Different manufacturers have different materials, joining systems and adhesives. Do not mix pipe, fittings, solvents, or joining methods from different BH Vent manufacturers, this can result in unsafe conditions.
- Consult PVC/CPVC manufacturer's installation manual for correct joining of pipe for gas venting.

#### General installation:

1. Cut pipe to required lengths and dry fit the venting and intake system to ensure a proper fit.
2. Disassemble the system and de burr the inside and outside of the pipe ends.
3. Chamfer the outside of each end of the pipes.
4. Make sure that each pipe end and fitting are clean. Once they are do not handle the joining surfaces.
5. Apply primer to both the fitting and the pipe end.
6. While the primer is damp, apply a even coating of cement to the pipe end and the fitting.
7. Insert the pipe into the fitting making sure the pipe is completely seated.
8. Rotate the pipe 1/4 turn and hold in place for 30 seconds.
9. Wipe any excess cement away and check that there is a complete bead of sealant around the joint of the fitting.
10. Allow to cure for 2 hours before commissioning the boiler.
11. Install perforated metal pipe supports onto the pipe, making sure there is no sagging in the pipe. Place supports as close as possible to elbows to relieve stress on the joint.

# PVC boiler adapter

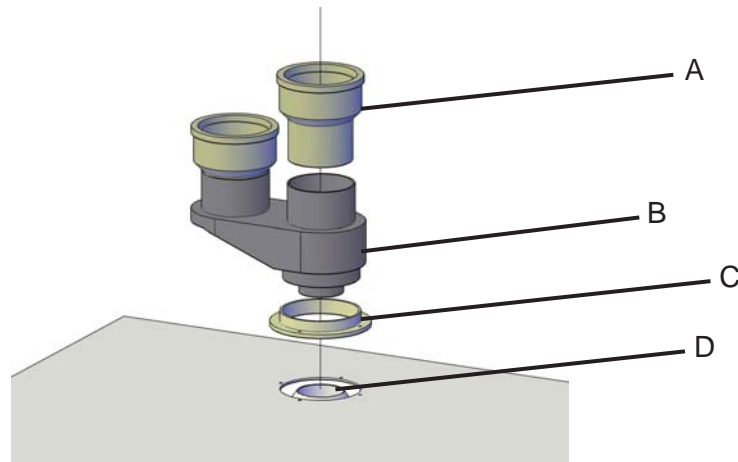

Figure 1.1

This kit is required to vent the Riva boiler using PVC/CPVC pipe. The kit includes a boiler connection adapted for PVC/CPVC. When venting with PVC/CPVC this boiler adapter is required in addition to one of the terminations on the following pages.

**Canada:** All PVC/CPVC pipe, fittings, and cement must be approved to ULC S636. Do not mix pipe and joining compounds from different manufacturers as this can result in an unsafe condition and void the certification.

## **Installation:**

- Attach the collar (C) from the adapter kit to the top of the boiler using the supplied screws.
- Insert the boiler adapter (B) into the collar. Check that the exhaust gasket (D) is installed on the outlet of the boiler first.
- Once the adapter is positioned in place, tighten the clamp on the collar and install the supplied self tapping screw through the pre drilled hole on the collar.
- Insert the PVC adapters (A) into the boiler adapter (B).
- Slide the CPVC/PVC pipe into the PVC adapters (A), do not use any solvents or cement on this connection. It is a gasket connection that requires no sealing.

# PVC concentric vent kit

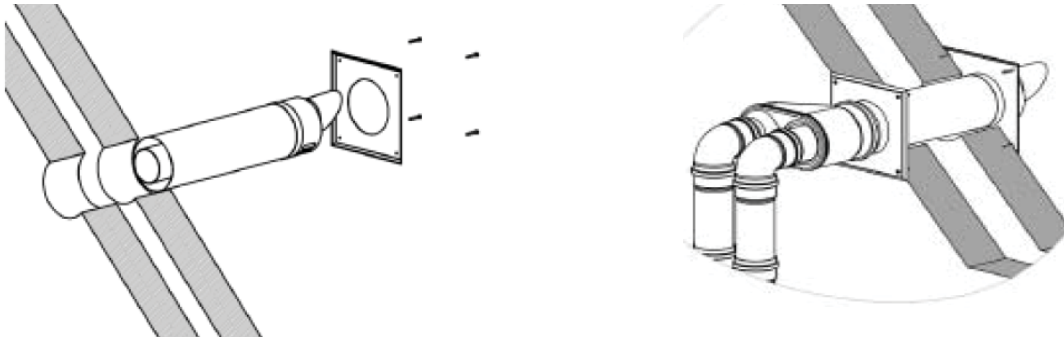

Figure 1.2

This kit allows horizontal termination of the flue pipe using PVC/CPVC pipe. The kit includes boiler connection and termination adapted for CPVC/PVC. 3" PVC/CPVC pipe may be added up to the total overall maximum permissible length of 100' intake and exhaust combined. Optional 45° and 90° elbows can be used to offset the flue route. Each additional elbow reduces the overall acceptable length of the flue system as follows:

Venting Specifications			
Max Length (intake + exhaust)	100 ft.	45° elbow	1.6 ft. equivalent
Min Length (intake + exhaust)	3 ft.	90° elbow	3.2 ft. equivalent

**Canada:** All PVC/CPVC pipe, fittings, and cement must be approved to ULC S636. Do not mix pipe and joining compounds from different manufacturers as this can result in an unsafe condition and void the certification.

## **Installation:**

- Drill 5.5" hole through the outside wall making sure there is 1 foot clearance above normal snow level.
- Insert the termination through the flexible exterior gasket and the building wall.
- Fix the exterior gasket to the wall using 4 contractor supplied fasteners.
- Slide the interior wall gasket over the termination and fix it to the wall using 4 user supplied fasteners.
- Assemble the gaskets into the twin pipe adapter.
- Install the twin pipe adapter onto the termination.
- Install the PVC adapters supplied onto the twin pipe adapter according the manufacturers instructions.
- Install piping pitched back toward the boiler making sure not to exceed the maximum allowable length.
- Intake air piping can be constructed of PVC pipe. Exhaust piping should be CPVC for the first 8 feet.
- Intake and exhaust piping should be assembled and secured according to the pipe manufacturers instructions.
- Install the vent adapter onto the top of the boiler using the gasket and screws provided.
- Install the pipe onto the boiler by simply pushing it into the adapters. Do not cement the pipe into the adapters, this is a gasket connection.

# PVC roof vent kit



Figure 1.3

This kit allows vertical termination of the flue pipe using PVC/CPVC pipe. The kit includes boiler connection and termination adapted for CPVC/PVC. 3" PVC/CPVC pipe may be added up to the total overall maximum permissible length of 100' intake and exhaust combined. Optional 45° and 90° elbows can be used to offset the flue route. Each additional elbow reduces the overall acceptable length of the flue system as follows:

Venting Specifications			
Max Length (intake + exhaust)	100 ft.	45° elbow	1.6 ft. equivalent
Min Length (intake + exhaust)	3 ft.	90° elbow	3.2 ft. equivalent

**Canada:** All PVC/CPVC pipe, fittings, and cement must be approved to ULC S636. Do not mix pipe and joining compounds from different manufacturers as this can result in an unsafe condition and void the certification.

## **Installation:**

- Choose the appropriate weather collar for the installation, Pitched or Flat.
- Drill a hole through the roof large enough to accommodate the 5.5" vent terminal.
- Fix the flue collar in place and insert the termination from outside the building.
- Fix the supplied wall clamp around the vent terminal but do not tighten it.
- Assemble the gaskets with the concentric pipe adapter. It may be necessary to use a small amount of water.
- Install the PVC adapters supplied onto the twin pipe adapter according the manufacturers instructions.
- Install piping to the boiler making sure not to exceed the maximum allowable length.
- Intake air piping can be constructed of PVC pipe. Exhaust piping should be CPVC for the first 8 feet.
- Intake and exhaust piping should be assembled and secured according to the pipe manufacturers instructions.
- Install the vent adapter onto the top of the boiler using the gasket and screws provided.
- Install the pipe onto the boiler by simply pushing it into the adapters. Do not cement the pipe into the adapters, this is a gasket connection.

# PVC separate vent kit

Figure 1.4

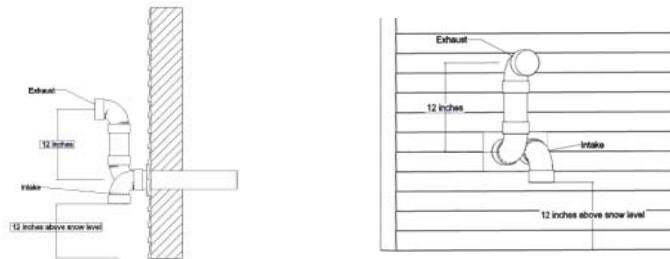

This kit allows horizontal termination of the flue pipe using 3" PVC/CPVC pipe. The kit includes PVC/CPVC boiler adapters and CPVC termination. PVC pipe may be added up to the total overall maximum permissible length. Optional 45° and 90° elbows can be used to offset the flue route. Each additional elbow reduces the overall acceptable length of the flue system as follows:

Venting Specifications			
Max Length (intake + exhaust)	100 ft.	45° elbow	1.6 ft. equivalent
Min Length (intake + exhaust)	3 ft.	90° elbow	3.2 ft. equivalent

**Canada:** All PVC/CPVC pipe, fittings, and cement must be approved to ULC S636. Do not mix pipe and joining compounds from different manufacturers as this can result in an unsafe condition and void the certification.

## **Installation:**

- Drill two 4" holes through the outside wall or the roof.
- Insert the pipes from the boiler through the wall making sure they slope towards the boiler.
- Intake air piping can be constructed of PVC pipe. Exhaust piping should be CPVC for the first 8 feet.
- Install the trim plate with the gasket facing the building using four field supplied screws.
- Secure the pipes in place inside the building using installer supplied hangers. Make sure there is no sagging or low spots for condensate to collect.
- Cut the intake and exhaust pipes so they extend at least 2 1/2" past the trim plate.
- Solvent cement a PVC elbow facing the ground onto the air intake. The Intake elbow must be at least 12" above normal snow level.
- Solvent cement a PVC/CPVC elbow facing up onto the exhaust outlet.
- Solvent Cement the 6" length of PVC/CPVC pipe into the elbow.
- Sovent Cement a PVC/CPVC elbow onto the pipe making sure the elbow faces away from the building.
- Install the rodent screens into the intake and exhaust. This is a friction fit.
- Install the vent adapter onto the top of the boiler using the gasket and screws provided.
- Install the pipe onto the boiler by simply pushing it into the adapters. Do not cement the pipe into the adapters, this is a gasket connection.