



HYDRONIC HEATING EQUIPMENT

bm[®]
Beacon/Morris



Horizontal and Vertical
Steam/Hot Water
Unit Heater



Beacon/Morris Hydronic Heating Equipment

Beacon/Morris has had broad experience in the manufacture of steam/hot water unit heaters for many years.

Offered in both horizontal and vertical air delivery models, Beacon/Morris unit heaters are a complete heat distributing plant, encased in an attractive, streamlined baked enamel housing. Designed for ceiling mounting, they provide a convenient, low cost method of heating warehouses, stores, factories, and other large open areas.

Beacon/Morris, responding to the requirements of the heating industry has now expanded its unit heater line to one of the most complete in the industry, twenty-three horizontal and fifteen vertical steam/hot water models!

Most Beacon/Morris unit heaters are equipped with totally enclosed motors with internal thermal overload, statically and dynamically balanced fans for quiet operation, and with the installer in mind, we designed a versatile hanging system for easy installation! Beacon/Morris horizontal unit heaters are attractively finished in dark gray jackets with dark gray air deflection louvers.

Beacon/Morris is proud of the reputation it has earned in the hydronic heating equipment market for product quality, design, innovations and customer service. The corporation has pledged its full range of engineering and manufacturing resources toward maintaining an unwavering commitment to the steam/hot water heating equipment industry.

Table of Contents

Introduction	2
Table of Contents	3
Application of Unit Heaters	4
Horizontal Unit Heaters	5
Steam Performance Data	6
Steam Calculations and Correction Factors	7
Hot Water Performance Data	8
Hot Water Calculations and Correction Factors	9
Technical Data	10
Mounting Heights and Throws	11
Dimensional Data	12
Standard Specifications	13
Serpentine Coil Dimensional Data	14
Serpentine Specification	15
Motor Characteristics – Horizontal Models	16
Vertical Unit Heaters	17
Steam Performance Data	18-19
Steam Calculations and Correction Factors	20
Hot Water Performance Data	21-22
Hot Water Performance Data	23-24
Hot Water Calculations and Correction Factors	25
Dimensional Data	26
Mounting Heights and Throws	27
Motor Characteristics	28
Piping and Installation – Horizontal & Vertical Models	29
Wiring Diagrams – Horizontal & Vertical Models	30
Warranties and Terms of Sale	30
Model Number Descriptions	31

Application of Unit Heaters

The proper choice and placement of a unit heater with regard to building type (architecturally) and application (area use) are two criteria, the importance of which cannot be overemphasized.

The first step in the design of a job is typically to determine the heat loss before considering CFM, final air temperature and quantity and location of units. ASHRAE and others publish the basic methodology used in calculating the building or area's heat loss.

Two requirements which not only affect the heat loss calculation but every other step of the job as well, are a detailed knowledge of the building's construction and its planned usage. The number of people, types of equipment and daily activities therein should be a strong guiding factor in the overall design.

Beacon/Morris's horizontal steam/hot water unit heaters are available in a range of outputs and airflows allowing almost unlimited flexibility in job design.

The following points offer some basic guidelines and suggestions which will be helpful in designing any job using horizontal steam/hot water unit heaters:

- Always direct airflow to areas of greatest heat loss.
- Adjust throw length with horizontal louvers.
- Use horizontal and vertical louvers for complete directional control of airflow.
- Mount units at the lowest practical and allowable level.
- Select lower CFM models for lower mounting heights and heavily occupied areas.
- The higher a unit must be located, the more CFM is required to get the heat down to the occupied zone.
- More, smaller units will provide better heat distribution than fewer larger ones.
- Watch final air temperatures on units mounted at lower levels or in heavily occupied areas to insure that air is warm enough to avoid drafts being felt.
- On motors with variable speed control use lower CFM rating for design base.
- Watch sound ratings.

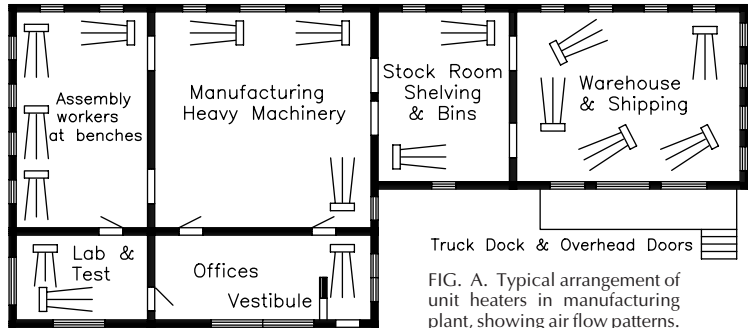
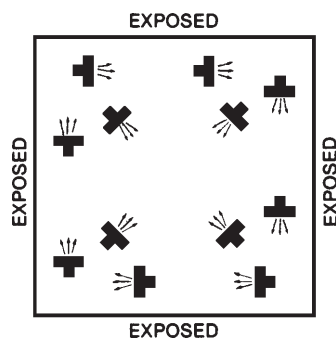
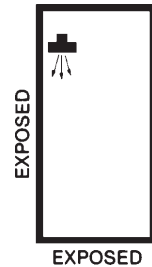

FIG. A. Typical arrangement of unit heaters in manufacturing plant, showing air flow patterns. Not to scale.



A large square area with exposed walls and roof; units are blanketing all exposed surfaces.

A narrow area with four exposed walls either with or without roof exposure.



A small area with exposed walls requiring one unit.

Horizontal Unit Heaters Construction and Features



MOTORS

115 volt, single speed motors are standard. Most models can be supplied with single phase, explosion proof motors. For standard motors in 230 volt or three-phase configuration, and three-phase explosion-proof motors, see page 16 for availability.

FAN GUARDS

All models with standard (non-explosion-proof) single phase 115 or 230 volt motors utilize a wire fan guard as a motor mount. OSHA type fan guards can be added as an optional accessory. All models with three-phase or explosion-proof motors are shelf-mounted. Standard fan guards can be added as an optional accessory.

HORIZONTAL AND VERTICAL LOUVERS

Horizontal louvers are standard on all models. Vertical louvers are available as optional equipment. Vertical louvers are installed on built to order units or shipped loose for field installation.

THERMOSTATS

Three, line voltage wall thermostats are in stock for immediate shipment. All models operate in a 45 to 85°F (7 to 28°C) range. Standard duty models with "off-auto" and "auto-off-fan" and a heavy duty model with "auto-off-fan" switching are available. Other models available on request. Plastic tamper-proof one size fits all thermostat guards are also available.

STRAP-ON WATER CONTROL

A SPDT strap-on type hot water control with 100° to 240°F (38 to 116°C) rated at 10 amps at 120V is also available. Control can be used for direct or reverse acting applications as a high or low limit.

STEAM PRESSURE CONTROL

SPST switch opens on a rise in pressure. Control is automatically reset, has a range of 0 to 15 PSIG (0 to 103 KPa) and has an adjustable differential. **Other actions, ranges, circuits and manual reset models are available on request.**

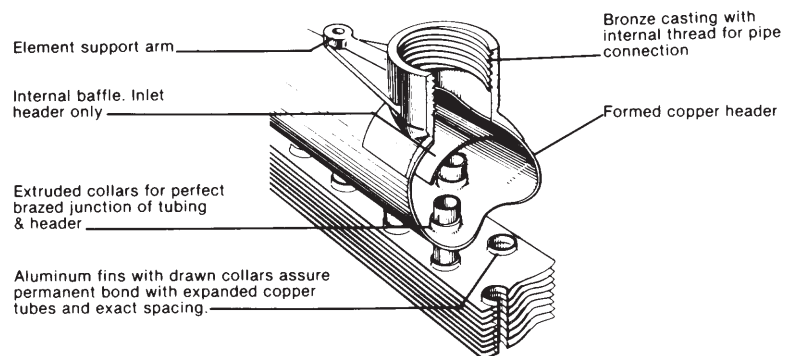
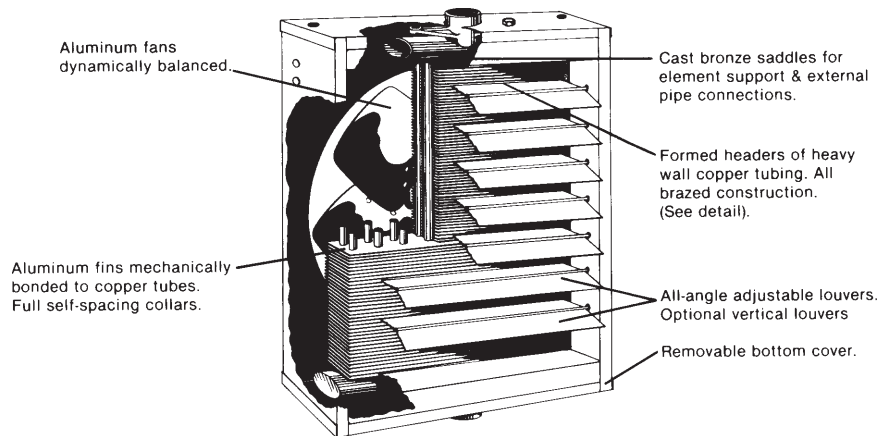

MANUAL STARTERS

Single and three-phase models are available. Standard models are single-speed, toggle-operated, NEMA Type 1 and are surface-mounted.

WALL MOUNTED SPEED CONTROLLERS

Units up to HB108 and VB104 with standard motors (115V) can be operated at reduced speeds by addition of optional speed controller. Controller is 5 amps, pre-set at factory for maximum and minimum speeds, with intermediate speeds infinitely controllable. All 1/3, 1/2 H.P. and 230V motors operate only at rated speed and CFM – See performance data charts.

Horizontal Unit Heaters

Steam Performance Data

Performance based on steam @ 2# at heater with air entering @ 60°F.

Max. Working Pressure 150 PSI, 366°F**

Model No.	Output BTU/HR*	Cond. lbs./hr.	Sq. Ft. E.D.R.	Final Air °F	Motor HP	RPM	Nominal CFM	Outlet FPM	Nom. Amps @ 115VAC†	Nom. Fan Diam. (Inches)
HB-18	18,000	18.0	75	102	16 Watt	1550	395	395	.80	9
	16,200	16.2	68	105		1350	330	330	.80	9
HB-24	24,000	24.5	100	109	16 Watt	1550	450	450	.80	10
	21,600	22.0	90	112		1350	380	380	.80	10
HB-36	36,000	37.0	150	119	25 Watt	1550	550	550	1.2	10
	32,400	33.0	135	120		1350	480	480	1.2	10
HB-48	48,000	49.0	200	119	1/20	1000	750	550	1.4	12
	43,200	44.0	180	123		900	630	460	1.4	12
HB-60	60,000	61.0	250	121	1/20	1000	900	650	1.4	12
	54,000	55.0	225	131		900	700	510	1.4	12
HB-72	72,000	73.0	300	120	1/20	1000	1100	800	1.4	14
	64,800	66.0	270	123		900	950	700	1.4	14
HB-84	84,000	85.0	350	115	1/12	1000	1400	900	2.2	14
	75,600	76.0	315	123		900	1100	750	2.2	14
HB-96	96,000	97.0	400	123	1/12	1000	1400	930	2.2	16
	86,400	88.0	360	132		900	1100	800	2.2	16
HB-108	108,000	110.0	450	115	1/12	1000	1800	1000	2.2	16
	97,200	98.0	405	120		900	1500	900	2.2	16
HB-120	120,000	122.0	500	118	1/3	1140	1900	900	4.5	18
	—	—	—	—		—	—	—	—	—
HB-132	132,000	134.0	550	121	1/3	1140	2000	950	4.5	18
	—	—	—	—		—	—	—	—	—
HB-144	144,000	146.0	600	120	1/3	1140	2200	1000	4.5	18
	—	—	—	—		—	—	—	—	—
HB-156	156,000	160.0	650	115	1/3	1140	2600	1150	4.5	18
	—	—	—	—		—	—	—	—	—
HB-180	180,000	190.0	770	135	1/3	1140	2200	800	4.5	18
	—	—	—	—		—	—	—	—	—
HB-204	204,000	208.0	850	124	1/3	1140	2900	1000	4.5	18
	—	—	—	—		—	—	—	—	—
HB-240	240,000	244.0	1000	123	1/3	1140	3500	900	4.5	20
	—	—	—	—		—	—	—	—	—
HB-280	280,000	280.0	1100	121	1/2	1100	4200	980	5.4	20
	—	—	—	—		—	—	—	—	—
HB-300	300,000	310.0	1250	117	1/2	1100	5000	700	5.4	24
	—	—	—	—		—	—	—	—	—
HB-360	360,000	366.0	1500	120	1/2	1100	5500	1000	5.4	24
	—	—	—	—		—	—	—	—	—

* For the lower output, an optional Speed Controller must be ordered.
For Sound Ratings See Pages 8 & 10.

**For further information see page 13, COIL MODELS.

†Stated AMP is full load (FLA). AMP draw varies by motor manufacturer ± .2 AMPS. See page 16 for motor data.

Steam Calculations and Correction Factors



		EXAMPLE: – UNIT: _____ HB-24 Steam Pressure _____ 10 PSI Entering Air Temp. _____ 40°F
I. CAPACITY A. For 2 lbs. steam, 60° entering air	Read output directly from table on p. 6, 24,000 BTU/HR. (Ref., Std. HB-24).	
B. For higher steam pressures and/or E.A.T.'s above or below 60°F	Multiply output from table on p. 6 by appropriate correction factor from table A (below).	24,000 x 1.29 = 30,960 BTU/HR.
II. FINAL AIR TEMPERATURE A. For 2 lbs. steam, 60° entering air	Read temperature directly from table on p. 6, 109°F. (Ref., Std. HB-24).	
B. For capacities calculated in I.B. (above)	$\frac{\text{Output from I.B.}}{1.085 \times \text{CFM from Table p. 6}} + \text{E..A.T.} = \text{Final Air Temp.}$	$\frac{30,960}{1.085 \times 450} + 40 = 103.4^\circ\text{F}$
III. FINAL AIR VOLUME A. For 2 lbs. steam, 60° entering air	$\frac{460 + \text{Final Air Temp from table on p. 6}}{530} \times \text{Nom. CFM from Table on p. 6} = \text{Final Air Volume}$	$\frac{460 + 109}{530} \times 450 = 483 \text{ CFM}$
B. For final air temperatures calculated in II. B. (above)	$\frac{460 + \text{Final Air Temp from II.B.}}{530} \times \text{Nom. CFM from Table on p. 6} = \text{Final Air Volume}$	$\frac{460 + 103.4}{530} \times 450 = 478 \text{ CFM}$
IV. CONDENSATE PER HOUR A. For 2 lbs. steam, 60° entering air	Read lbs. per hour from table on p. 6, 24.5 LBS./HR. (Ref., Std. HB-24).	
B. For capacities calculated in I.B. (above)	$\frac{\text{Output from I.B.}}{\text{Latent Heat From Table B}} = \text{lbs. per hour of condensate}$	$\frac{30,960}{953} = 32.5 \text{ LBS./HR.}$

TABLE A — STEAM CORRECTION FACTORS BASED ON 2 LBS. STEAM 60° E.A.T.

ENTERING AIR TEMPERATURE	STEAM PRESSURE — LBS. PER SQ. IN. (SATURATED)												
	0	2	5	10	15	20	30	40	50	75	100	125	150
30°	1.19	1.24	1.29	1.38	1.44	1.50	1.60	1.68	1.70	1.90	2.02	2.11	2.20
40°	1.11	1.16	1.21	1.29	1.34	1.42	1.51	1.60	1.60	1.81	1.93	2.02	2.11
50°	1.03	1.08	1.13	1.21	1.28	1.33	1.43	1.51	1.58	1.72	1.84	1.93	2.02
60°	0.96	1.00	1.05	1.13	1.19	1.25	1.35	1.43	1.50	1.64	1.75	1.84	1.93
70°	0.88	0.93	0.97	1.06	1.12	1.17	1.27	1.35	1.42	1.55	1.66	1.76	1.84
80°	0.81	0.85	0.90	0.98	1.04	1.10	1.19	1.27	1.34	1.47	1.58	1.68	1.76
90°	0.74	0.78	0.83	0.91	0.97	1.02	1.12	1.19	1.26	1.39	1.50	1.59	1.67
100°	0.67	0.71	0.76	0.84	0.89	0.95	1.04	1.12	1.19	1.32	1.42	1.51	1.59

TABLE B — PROPERTIES OF SATURATED STEAM

	STEAM PRESSURE IN LBS. PER SQUARE INCH GAUGE												
	0	2	5	10	15	20	30	40	50	75	100	125	150
Steam Temperature-°F	212.0	218.5	227.1	239.4	249.8	258.8	274.0	286.7	297.7	319.9	337.9	352.9	365.9
Latent Heat of Steam	970	966	961	953	946	940	929	920	912	891	881	868	857

Horizontal Unit Heaters

Hot Water Performance Data

Performance based on 200° EWT, 60° E.A.T., 20° TD.

Model No.	Output BTU/HR*	GPM	Final Air °F	Prssr. Drop FT./H ₂ O	Motor HP	RPM	Nominal CFM	Outlet FPM	Nom. Amps @ 115VAC†	Sound Rating
HB-108A	8,030	.80	91	.80	16 Watt	1550	245	250	.80	II
	6,800		90			1350	210	215	.80	I
HB-118A	18,400	1.9	94	2.2	16 Watt	1550	500	500	.80	II
	15,650		96			1350	420	420	.80	I
HB-125A	24,800	2.5	102	2.2	25 Watt	1550	580	590	1.2	II
	21,230		106			1350	460	450	1.2	I
HB-136A	35,900	3.6	99	3.0	1/20	1000	850	550	1.4	II
	32,300		100			900	750	480	1.4	I
HB-18	13,050	1.3	95	.005	16 Watt	1550	395	395	.80	II
	11,725		99			1350	350	350	.80	I
HB-24	17,400	1.8	96	.014	16 Watt	1550	450	450	.80	II
	15,600		98			1350	380	380	.80	I
HB-36	26,100	2.7	103	.09	25 Watt	1550	550	550	1.2	II
	23,500		103			1350	480	480	1.2	I
HB-48	34,800	3.5	103	.12	1/20	1000	750	550	1.4	II
	31,300		111			900	630	460	1.4	I
HB-60	43,600	4.4	105	.17	1/20	1000	900	650	1.4	II
	39,200		112			900	700	510	1.4	I
HB-72	52,300	5.3	104	.23	1/20	1000	1100	800	1.4	II
	47,000		106			900	950	700	1.4	I
HB-84	61,000	6.1	100	.24	1/12	1000	1400	900	2.2	III
	54,900		106			900	1100	750	2.2	II
HB-96	69,700	7.0	106	.29	1/12	1000	1400	930	2.2	III
	62,700		113			900	1100	800	2.2	II
HB-108	78,400	7.9	100	.36	1/12	1000	1800	1000	2.2	III
	70,500		103			900	1500	900	2.2	II
HB-120	87,100	8.8	102	.39	1/3	1140	1900	900	4.5	III
	—		—			—	—	—	—	—
HB-132	95,800	9.6	104	.41	1/3	1140	2000	950	4.5	IV
	—		—			—	—	—	—	—
HB-144	104,000	10.4	104	.43	1/3	1140	2200	1000	4.5	IV
	—		—			—	—	—	—	—
HB-156	113,000	11.3	100	.53	1/3	1140	2600	1150	4.5	IV
	—		—			—	—	—	—	—
HB-180	118,000	11.8	110	.60	1/3	1140	2200	800	4.5	III
	—		—			—	—	—	—	—
HB-204	148,100	14.9	107	.79	1/3	1140	2900	1000	4.5	IV
	—		—			—	—	—	—	—
HB-240	174,000	17.4	106	1.06	1/3	1140	3500	900	4.5	IV
	—		—			—	—	—	—	—
HB-280	209,100	21.0	106	1.33	1/2	1100	4200	980	5.4	IV
	—		—			—	—	—	—	—
HB-300	230,000	23.0	102	2.1	1/2	1100	5000	700	5.4	IV
	—		—			—	—	—	—	—
HB-360	261,300	26.2	103	2.1	1/2	1100	5500	1000	5.4	IV
	—		—			—	—	—	—	—

* For the lower output, an optional Speed Controller must be ordered.

For Fan Diameter See Page 6.

† Stated AMP is full load (FLA). AMP draw varies by motor manufacturer ± .2 AMPS. See page 16 for motor data.

Hot Water Calculations and Correction Factors



		EXAMPLE: – UNIT: _____ HB-24 Entering Water Temp. _____ 160°F Entering Air Temp. _____ 40°F Water Temperature Drop _____ 10°F
I. CAPACITY @ 20° TD: A. For 200° EWT, 60° EAT	Read output directly from table on p. 8, 17,400 BTU/HR (Ref., Std. HB-24).	
B. For EWT and/or EAT above or below Standard	Multiply output from table on p. 8 by factor from table A (below).	17,400 x .878 = 15,277 BTU/HR.
II. CAPACITY AT OTHER TD's A. For TD's from 5 to 60°F	Multiply output obtained in IA. or IB. (above) by appropriate factor from Table B (below)	IA - 17,400 x 1.15 = 20,010 BTU/HR. –OR– IB - 15,277 x 1.15 = 17,569 BTU/HR.
III. GPM AT OTHER TD's A. For TD's from 5 to 60°F	Multiply GPM of unit for 20° TD, from table on p. 8 by appropriate factor from table B (below).	1.8 x 2.30 = 4.14 GPM (Applies only to units with Std. 200° EWT, 60° EAT.) For all others calculate using formula – $GPM = \frac{BTU}{500 \times TD}$
IV. CAPACITY AT OTHER RATES OF WATER FLOW	Multiply output from table on p. 8 by factor from Table D (below).	
V. PRESSURE LOSS AT OTHER TD's A. For TD's from 5 to 60°F	Multiply P.D. of unit for 20° TD, from table on p. 8 by appropriate factor from table B (below).	.014 x 5.00 = .07 Ft. H ₂ O

TABLE A — HOT WATER CONVERSION FACTORS BASED ON 200° ENTERING WATER 60° ENTERING AIR 20° TEMPERATURE DROP

ENTERING AIR TEMPERATURE	ENTERING WATER TEMPERATURE — 20° WATER TEMPERATURE DROP										
	100°	120°	140°	160°	180°	200°	220°	240°	260°	280°	300°
30°	0.518	0.666	0.814	0.963	1.120	1.268	1.408	1.555	1.702	1.850	1.997
40°	0.439	0.585	0.731	0.878	1.025	1.172	1.317	1.464	1.609	1.755	1.908
50°	0.361	0.506	0.651	0.796	0.941	1.085	1.231	1.375	1.518	1.663	1.824
60°	0.286	0.429	0.571	0.715	0.857	1.000	1.143	1.286	1.429	1.571	1.717
70°	0.212	0.353	0.494	0.636	0.777	0.918	1.060	1.201	1.342	1.483	1.630
80°	0.140	0.279	0.419	0.558	0.698	0.837	0.977	1.117	1.257	1.397	1.545
90°	0.069	0.207	0.345	0.483	0.621	0.759	0.897	1.035	1.173	1.311	1.462
100°	0	0.137	0.273	0.409	0.546	0.682	0.818	0.955	1.094	1.230	1.371

TABLE B — HOT WATER BTU, GPM AND PRESSURE LOSS FACTORS BASED ON STANDARD CONDITIONS OF 200°F ENTERING WATER 60°F ENTERING AIR & 20°F WATER DROP

USE FACTORS FROM THIS TABLE TO OBTAIN APPROXIMATE RESULTS	TEMPERATURE DROP °F									
	5	10	15	20	25	30	40	50	60	
To obtain BTU for other Water Temperature Drops, multiply basic BTU rating by applicable Factor.	1.25	1.15	1.08	1.00	.94	.90	.83	.76	.72	
To obtain GPM for other Water Temperature Drops, multiply basic GPM rating by applicable Factor.*	5.00	2.30	1.44	1.00	.74	.59	.40	.30	.24	
To obtain Pressure Loss Feet of Water for other temperature Drops, multiply Basic loss at 20° drop by Factor.	10.00	5.00	2.00	1.00	.60	.40	.20	.13	.07	

***TABLE C — MINIMUM WATER FLOW — GPM**

MODEL No.	HB108A	HB118A	HB125A	HB136A	HB18	HB24	HB36	HB48	HB60	HB72	HB84	HB96
MIN. GPM	.125	.125	.125	.125	.75	1.24	1.24	1.49	1.49	1.62	1.86	3.35
MODEL No.	HB108	HB120	HB132	HB144	HB156	HB180	HB204	HB240	HB280	HB300	HB360	
MIN. GPM	3.35	3.60	4.09	4.09	4.09	4.34	4.34	4.59	4.59	6.08	6.08	

***TABLE D — HEATING CAPACITY FACTORS FOR VARIOUS RATES OF WATER FLOW**

% of Rated Water Flow	25%	50%	75%	100%	125%	150%	175%
Btu/Hr Heating Capacity	.80	.89	.96	1.00	1.04	1.07	1.10

Horizontal Unit Heaters

Technical Data

The performance data listed on page 8 includes sound ratings. The ratings provide a guide in determining the acceptable degree of loudness in particular occupancy situations.

Certain general rules apply to specific selection of unit heaters with regard to degree of quietness (or loudness);

- The greater the fan diameter, the higher the sound level.
- The higher the motor RPM, the higher the sound level. Note that on most units the lower the speed mode results in lowering the sound rating one increment.
- Selecting a larger number of smaller units generally results in lower overall noise levels than fewer large units.

All horizontal steam and hot water unit heater motors, whether fan guard or shelf-mounted, are isolated from the mechanical mount by resilient isolators. This mounting along with balanced fan blades and excellent overall construction integrity, assures you the utmost in quiet operation.

The following table outlines sound ratings for various applications. The lower the number, the quieter the unit and the lower the sound requirement.

CATEGORY OF AREA	SOUND RATING
Apartment, assembly hall, classrooms churches, courtrooms, executive offices, hospitals, libraries, museums, theatres.	I
Dining rooms, general offices, recreation areas, small retail stores.	II
Restaurants, banks, cafeterias, department stores, public buildings, service stations.	III
Gymnasiums, health clubs, laundromats, supermarkets.	IV
Garages, small machine shops, light manufacturing.	V
Factories, foundries, steel mills.	III - VII*

*Depending on specific use in these facilities, size of operation, etc.

CORRECTIONS WHEN USING GLYCOL SOLUTION IN SYSTEM

	Propylene Glycol
1. Heat transfer @180°F with no increase in flow rate	.97*
20% solution	
50% solution	.90*
2. G.P.M. Req'd. @180°F, 20° Δ t (no correction to pump curve)	1.10%*
3. Pump Head Req'd. @180°F w/increase in G.P.M.	1.23%*
4. Specify gravity (water = 1.0)	1.045-1.055*
5. Pounds/Gallons @60°F (water = 8.3453 Pound/Gallon)	8.77
6. pH @ 50% by volume	9.5

	Propylene Glycol
7. Freezing Point 55% by volume	-
50%	-28°F
40%	-13°F
30%	+ 4°F
20%	+17°F

*Compared to water.

Approximate factors at varying altitudes

Altitude	Factor
Sea level - 1000 ft.	1.00
1000 ft. - 3000 ft.	.958
3000 ft. - 5000 ft.	.929
5000 ft. - 7000 ft.	.900
7000 ft. - 10000 ft.	.871

Mounting Heights and Throws

The following table is based on 60° entering air and either 2 lb. steam or 200° water with a 20° T.D. The data is based on the higher speed CFM throughout and velocity. Care should be exercised in locating adjacent unit heaters and allowance should be made for obstructions in the air pattern and conflicting air currents from other air moving devices.

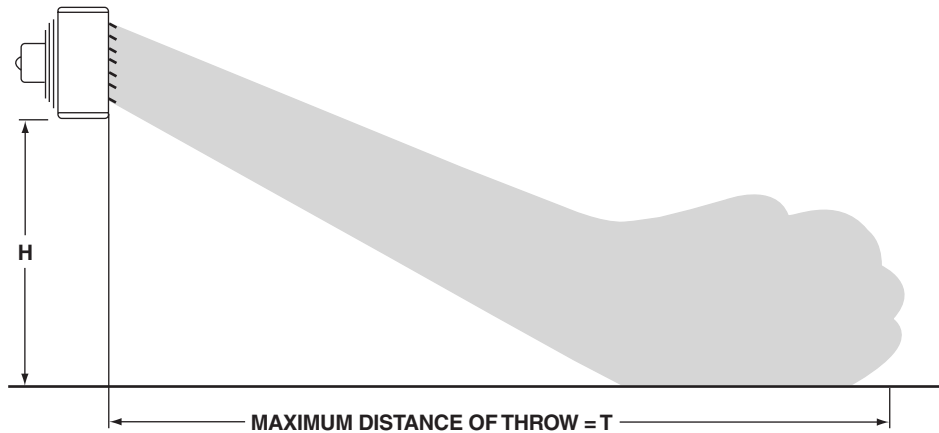

MODEL NO.	MAXIMUM MOUNTING HT.	APPROX. MAX. THROW	MODEL NO.	MAXIMUM MOUNTING HT.	APPROX. MAX. THROW
HB-108A	8	20	HB-108	11	40
HB-118A	8	25	HB-120	12	40
HB-125A	9	29	HB-132	13	54
HB-136A	9	29	HB-144	13	55
HB-18	8	20	HB-156	13	55
HB-24	8	24	HB-180	13	53
HB-36	9	28	HB-204	13	55
HB-48	9	30	HB-240	14	57
HB-60	10	30	HB-280	14	57
HB-72	10	29	HB-300	15	58
HB-84	10	30	HB-360	15	60
HB-96	11	38			

Horizontal Unit Heaters

Dimensional Data

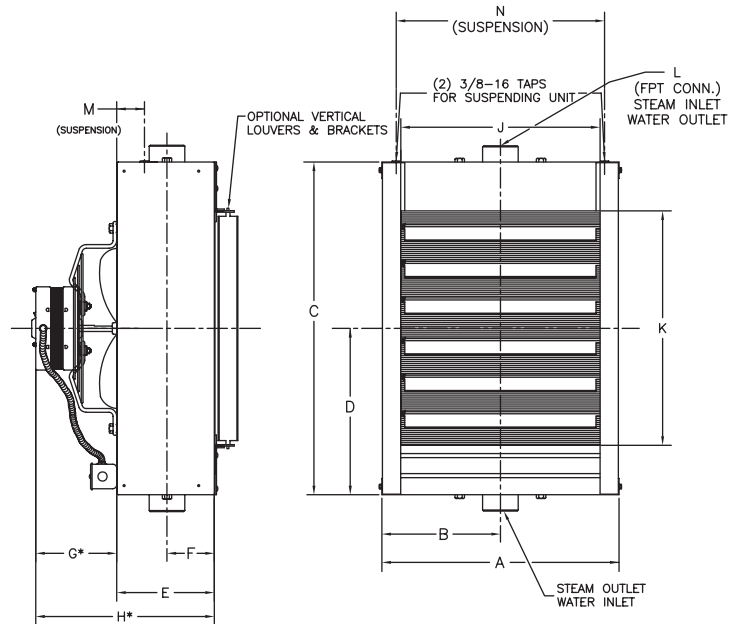

D6333B

MODELS HB-18 THRU 360 (HEADER TYPE)

MODEL	A	B	C	D	E	F	G*	H*	J	K	L	M	N	NO. OF LOUVERS	NOM. FAN DIAM.	APPROX. SHIP WT.
HB-18	14 ⁵ / ₈	7 ⁵ / ₁₆	15	7 ¹ / ₂	6 ¹ / ₈	2 ¹⁵ / ₁₆	3 ¹ / ₄	9 ³ / ₈	12 ¹ / ₄	9 ¹ / ₂	1 ¹ / ₄	2 ¹ / ₄	12 ⁷ / ₈	4	9	26
HB-24 HB-36	14 ⁵ / ₈	7 ⁵ / ₁₆	18	9	6 ¹ / ₈	2 ¹⁵ / ₁₆	3 ¹ / ₄	9 ³ / ₈	12 ¹ / ₄	12 ¹ / ₂	1 ¹ / ₄	2 ¹ / ₄	12 ⁷ / ₈	5	10	30
HB-48 HB-60	17 ¹ / ₈	8 ⁹ / ₁₆	20 ¹ / ₂	10 ¹ / ₄	5 ⁷ / ₈	2 ¹⁵ / ₁₆	5 ¹ / ₁₆	10 ¹⁵ / ₁₆	14 ³ / ₄	15	1 ¹ / ₄	1 ³ / ₄	15 ³ / ₈	6	12	41
HB-72	18 ³ / ₈	9 ³ / ₁₆	21 ³ / ₄	10 ⁷ / ₈	6	2 ¹⁵ / ₁₆	5 ¹ / ₁₆	11 ¹ / ₁₆	16	16 ¹ / ₄	1 ¹ / ₄	1 ³ / ₄	16 ⁵ / ₈	7	14	44
HB-84	20 ⁷ / ₈	10 ⁹ / ₁₆	24 ¹ / ₄	12 ¹ / ₈	6 ¹ / ₈	2 ¹⁵ / ₁₆	5 ¹¹ / ₁₆	11 ¹³ / ₁₆	18 ¹ / ₂	18 ³ / ₄	1 ¹ / ₄	1 ³ / ₄	19 ¹ / ₈	7	14	47
HB-96 HB-108	19 ⁵ / ₈	9 ¹³ / ₁₆	24	12	6 ⁵ / ₁₆	3 ³ / ₁₆	7 ¹ / ₂	13 ¹³ / ₁₆	17 ¹ / ₄	17 ¹ / ₂	1 ¹ / ₂	1 ³ / ₄	17 ⁷ / ₈	8	16	49
HB-120	20 ⁷ / ₈	10 ⁷ / ₁₆	25 ¹ / ₄	12 ⁵ / ₈	6 ⁵ / ₁₆	3 ³ / ₁₆	6 ¹¹ / ₁₆	13	18 ¹ / ₂	18 ³ / ₄	1 ¹ / ₂	1 ³ / ₄	19 ¹ / ₈	8	18	59
HB-132 HB-144	23 ³ / ₈	11 ¹¹ / ₁₆	27 ³ / ₄	13 ⁷ / ₈	6 ⁵ / ₁₆	3 ³ / ₁₆	7 ⁵ / ₈	14	21	21 ¹ / ₄	1 ¹ / ₂	1 ³ / ₄	21 ⁵ / ₈	9	18	74
HB-156	23 ³ / ₈	11 ¹¹ / ₁₆	27 ³ / ₄	13 ⁷ / ₈	6 ⁵ / ₁₆	3 ³ / ₁₆	7 ⁷ / ₁₆	13 ³ / ₄	21	21 ¹ / ₄	1 ¹ / ₂	1 ³ / ₄	21 ⁵ / ₈	9	18	74
HB-180 HB-204	24 ⁵ / ₈	12 ⁵ / ₁₆	29	14 ¹ / ₂	6 ³ / ₈	3 ³ / ₁₆	7 ⁷ / ₁₆	13 ³ / ₄	22 ¹ / ₄	22 ¹ / ₂	1 ¹ / ₂	1 ³ / ₄	22 ⁷ / ₈	9	18	90
HB-240	27 ⁷ / ₈	13 ¹⁵ / ₁₆	30 ¹ / ₄	15 ¹ / ₈	8 ¹ / ₈	3 ³ / ₁₆	5 ⁷ / ₈	14	25 ¹ / ₂	23 ³ / ₄	2	1 ³ / ₄	26 ¹ / ₈	10	20	125
HB-280	27 ⁷ / ₈	13 ¹⁵ / ₁₆	30 ¹ / ₄	15 ¹ / ₈	8 ¹ / ₈	3 ³ / ₁₆	9 ⁵ / ₈	17 ³ / ₄	25 ¹ / ₂	23 ³ / ₄	2	1 ³ / ₄	26 ¹ / ₈	10	20	118
HB-300 HB-360	33 ³ / ₈	16 ¹¹ / ₁₆	37 ³ / ₄	18 ⁷ / ₈	9	3 ³ / ₁₆	9 ⁵ / ₈	18 ⁵ / ₈	31	31 ¹ / ₄	2	1 ³ / ₄	31 ⁵ / ₈	13	24	154

* APPLIES TO STANDARD MOTOR WITH STANDARD FAN GUARD. WHEN OPTIONAL MOTORS OR OSHA FAN GUARDS ARE REQUESTED, DIMENSIONS WILL CHANGE ACCORDING TO THE SUBSTITUTIONS MADE.

NOTES: 1. Standard motor and standard guard shown.

2. Optional OSHA guards available for all units with 1 phase motors.

3. All 3 phase and explosion proof motors are shelf mounted.

Specifications

GENERAL

Furnish and install, where indicated or scheduled on plans Beacon/Morris Model HB horizontal steam/hot water unit heaters. Unit shall be equipped as specified herein. All units shall be installed in a neat and workmanlike manner in accordance with this specification and the manufacturer's installation instruction.

CASING

Casings shall be 20 gauge die-formed steel. Casing substrates shall be prepared for finishing with a hot wash, iron phosphatizing clear rinse, chromic acid rinse and oven drying. Paint finish shall be of lead-free, chromate free, alkyd melamine resin base and applied with an electrostatic two-pass system. Finish shall be baked at 350°F.

COIL MODELS 18 – 360

Coil elements and headers shall be of heavy wall drawn seamless copper tubing. Element tubes shall be brazed into extruded header junctions. Pipe connection saddles shall be of cast bronze. Aluminum fins shall have drawn collars to assure permanent bond with expanded element tubes and exact spacing. All Element Assemblies are submersion tested at factory at 250 P.S.I., and are rated at 150 pounds of saturated steam pressure at 366°F, under maximum load conditions. We recommend operating pressure of 75 P.S.I. at 320°F for long life.

MOTORS

Motors shall be totally enclosed, resilient mounted with class "B" windings. All motors shall be designed for horizontal mounting. Motors under 1/3 H.P. are totally enclosed, frame mounted, 115/1/60 with thermal overload protection and permanently lubricated sleeve bearings with optional solid state speed controller available. 1/3 H.P. (115/1/60) motors are open frame construction, with thermal overload protection and ball bearings. 1/3 H.P. at (230V) and 1/2 H.P. (230V) motors are open frame construction, with thermal overload protection and ball bearings. 1/3 and 1/2 H.P. motors are available in single and 3 phase in open frame construction or explosion-proof housings, all the above are available as options.



EXPLOSION PROOF MOTORS

An enclosed motor whose enclosure is designed and constructed to withstand an explosion of a specific gas or vapor which may occur within the motor and to prevent the ignition of this gas or vapor surrounding the machine.

Beacon/Morris motors comply with the National Electrical Code classification as follows:

- Class I, Group D; all sizes
- Class II, Group F; all sizes
- Class II, Group G; all sizes
- Division I & II Installations
- T-code (T3B)

Explosion proof equipment is not generally available for Class I, Groups A and B and it is necessary to isolate motors from the hazardous area. All explosion proof motors are shelf mounted.

FANS

Fans shall be of the aluminum blade, hub type designed and balanced to assure maximum air delivery, low motor horsepower requirements and quiet operation. Blades are spark proof.

FAN GUARDS

Fan guards shall be welded steel, zinc plated or painted. To meet CSA and OSHA requirements, units mounted below 8 feet from floor must be equipped with an OSHA fan guard. OSHA fan guards are optional.

AIR DEFLECTION LOUVERS

Units shall be equipped with horizontal, individually adjustable louvers. Vertical louvers for four-way air control shall be available as an optional extra.

Horizontal Unit Heaters

Serpentine Coil Dimensional Data

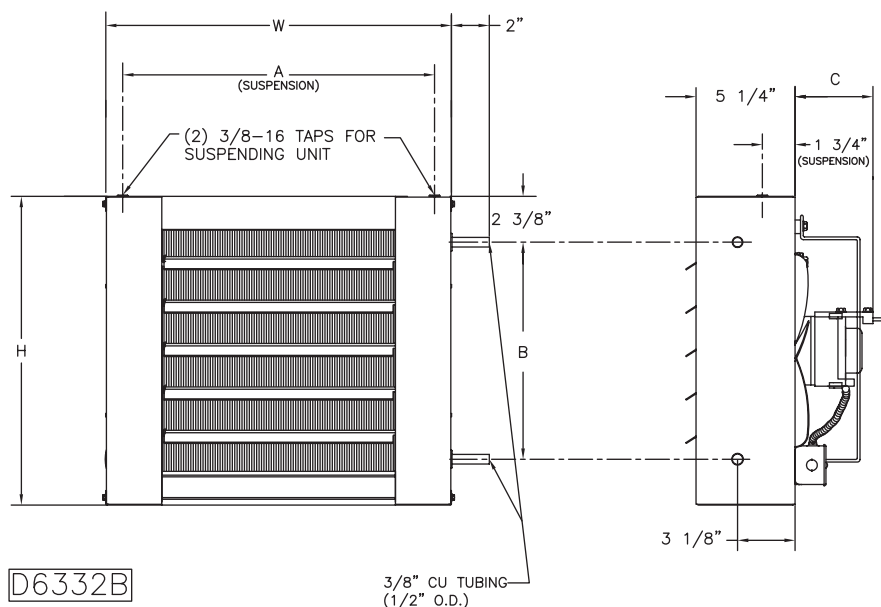

NOTE: Motors are totally enclosed, thermally protected, sleeve bearing, with 2" (h) x 4" (w) conduit connection boxes. Nutserts are attached to enclosure for balanced hanging.

STANDARD SPECIFICATION

MODEL NO.	H	W	A	B	C	NO. LOUVERS	NOM. FAN DIAM.	APPROX. SHIP WT.
HB-108A	16	18	16-7/32	11-1/4	4-1/4	5	9	22
HB-118A	16	18	16-7/32	11-1/4	4-1/4	5	10	24
HB-125A	16	18	16-7/32	11-1/4	4-1/4	5	10	25
HB-136A*	18-1/2	20-1/2	18-23/32	13-3/4	5-1/8	6	12	31

* DIMENSION "C" IS TO BACK OF MOTOR, NOT MOTOR CONDUIT CONNECTOR AS SHOWN ABOVE.

Serpentine Coil Specifications



GENERAL

Furnish and install, where indicated or scheduled on plans Beacon/Morris Model HB-A horizontal hot water unit heaters. Unit shall be equipped as specified herein. All units shall be installed in a neat and workmanlike manner in accordance with this specification and the manufacturer's installation instruction.

CASING

Casings shall be 20 gauge die-formed steel. Casing substrates shall be prepared for finishing with a hot wash, iron phosphatizing clear rinse, chromic acid rinse and oven drying. Paint finish shall be of lead-free, chromate free, alkyd melamine resin base and applied with an electrostatic two-pass system. Finish shall be baked at 350°F.

COIL MODELS HB108A – HB136A

Coil is a serpentine design with seamless copper tubing. Aluminum fins shall have drawn collars to assure permanent bond with expanded tubes. Tubing connection shall be $\frac{3}{8}$ " copper tubing, type "M" (.500 O.D.). Coils shall be factory *tested* at 250 P.S.I.

MOTORS

Motors shall be totally enclosed, resilient mounted with class "B" windings. All motors shall be designed for horizontal mounting.

FANS

Fans shall be of the aluminum blade type, designed and balanced to assure maximum air delivery, low motor horsepower requirements and quiet operation.

FAN GUARDS

Fan guards shall be welded steel, zinc plated or painted. To meet CSA and OSHA requirements, units mounted below 8 feet from floor must be equipped with an OSHA fan guard. OSHA fan guards are also available.

AIR DEFLECTION LOUVERS

Units shall be equipped with horizontal, individually adjustable louvers.



Horizontal Unit Heaters

Motor Characteristics

TOTALLY ENCLOSED MOTOR TYPE

HB Unit Model No.	AMP	MCA	HP	RPM
115/1/60				
18, 24, 108A, 118A	0.8	1.0	16W*	1550
136A	1.4	1.8	1/20*	1000
36, 125A	1.2	1.5	25W*	1550
48, 60, 72	1.4	1.8	1/20*	1000
84, 96, 108	2.2	2.8	1/12*	1000
120, 132, 144, 156, 180, 204, 240	4.5	5.6	1/3	1140
280, 300, 360	5.4	6.8	1/2	1100
230/1/60				
18, 24, 108A, 118A	0.4	0.5	16W	1550
136A	1.4	1.8	1/20†	1000
36, 125A	0.6	0.8	25W	1550
48, 60, 72	1.4	1.8	1/20†	1000
84, 96, 108	2.2	2.8	1/12†	1000
120, 132, 144, 156, 180, 204, 240	4.5	5.6	1/3†	1140
280, 300, 360	5.4	6.8	1/2†	1100
208-230/460/3/60				
48, 60, 72, 84, 96, 108, 120, 132, 144, 156, 180, 204, 240, 280, 300, 360	2.6-2.6/1.3	3.3-3.3/1.6	1/2**	1140

*Optional variable speed switch is available.

**These motors are without thermal overload protection

NOTE 1: All motors are constant speed and operate at top speed as indicated in motor data. Models 18 through 108, including 108A, 118A, 125A and 136A can be run at reduced speed with addition of optional variable speed switch. This switch is factory-calibrated for low and high speed ratings, with intermediate speeds infinitely controllable. Models 120 through 360 operate at constant speed as indicated in motor data. All 1/4 H.P. motors are P.S.C.

NOTE 2: Motors under 1/3 H.P. are totally enclosed, frame mounted, 115/1/60 with thermal overload protection and permanently lubricated sleeve bearings with optional speed controller available. 1/3 H.P. (115/1/60) motors are open frame constant speed with thermal over-load protection and ball bearings. 1/3 H.P. (230V) and 1/2 H.P. (230V) motors are open frame constant speed with thermal overload protection and ball bearings.

EXPLOSION PROOF WITH THERMAL OVERLOAD MOTOR TYPE

HB Unit Model No.	AMP	MCA	HP	RPM
115/1/60				
48, 60, 72, 84, 96, 108, 120, 132	3.7	4.6	1/6	1140
144, 156, 180, 204	5.4	6.8	1/4	1140
240, 280, 300	7.4	9.3	1/3***	1140
360	7.4	9.3	1/2***	1140
230/1/60				
48, 60, 72, 84, 96, 108, 120, 132	3.7	4.6	1/6†	1140
144, 156, 180, 204	5.4	6.8	1/4†	1140
240, 280, 300	3.7	4.7	1/3***	1140
360	3.7	4.7	1/2***	1140
230/460/3/60				
144, 156, 180, 204, 240, 280, 300, 360	2.2/1.1	2.8/1.4	1/3	1140

***These motors are 115/230 volts.

†230/1/60 unit has 115/1/60 motor supplied with field installed stepdown transformer

NOTE 3: 1/3 and 1/2 H.P. motors are available as 230V single and 3 phase in open frame and explosion-proof housings, all available as options. 1/3 and 1/2 H.P. motors operate at single speed only.

NOTE 4: Stated AMP draw is Full Load Amp (FLA). AMP draw varies by motor manufacturer \pm .2 AMPS. Verify FLA per unit motor data plate.

CAUTION: Select appropriate AMP and MCA for the multiple voltage motors. For example, the AMP and MCA for Models 360 with a 460 volt Totally Enclosed motor is 1.3 and 1.6 respectively.

Vertical Unit Heaters Features and General Specifications



Beacon/Morris vertical projection unit heaters provide heat where required in commercial and industrial applications. Mounted near the ceiling, this unit provides air circulation and reduces stratification, without occupying otherwise usable building space. Units can be provided with an optional diffuser for patterned discharge, or, without a diffuser for higher velocity 'spot' heating near doorways and other high-loss areas.

Beacon/Morris vertical units are available in fifteen sizes for steam or hot water heating. Steam capacities range from 140 to 2,580 E.D.R. (26.0 to 705 MBH) (2 PSI w/60° E.A.T.). Hot water capacities range from 18.9 to 519.4 MBH (200° E.W.T./20° drop w/60° E.A.T.).

CONSTRUCTION

The unit casing is formed by two square steel plates. The bottom plate forms an orifice for air delivery. Air ports are stamped in the top plate of standard units for easy conversion to low output units.

FAN

Beacon/Morris aluminum blade fans are quiet, factory balanced and sturdy for standard or sparkproof applications.

HEATING ELEMENT

Hot water-steam coils are rectangular 3 or 4-sided, one-pass, multiple circuit, with aluminum fins mechanically bonded to the tubes. Standard coils are seamless copper tubing. Coils tested at 375 psi under water. Supply and return connections are steel pipe. Standard coils have .025 copper tubing suitable for use on steam pressure to 75 psi or hot water up to 225 psi or 325°F.



MOTORS

Standard motors are 115/60/1, totally enclosed, with thermal overload protection for all units through size VB-280. Standard motors for sizes 40, 62 and 77 are shaded pole, sleeve bearing. The VB-104 motor is permanent split capacitor type with sleeve bearings. Motor for unit sizes 125 through 285 are permanent split capacitor types with permanently lubricated ball bearings. Motors used on unit sizes 317 through 700 are 230/460/60/3, totally enclosed, with permanently lubricated ball bearings. Unit sizes smaller than 317 are also available with 230/460/60/3 motors.

All motors fractional H.P. and integral H.P., have Class "B" insulation. The 115/60/1 motors used as standard on unit sizes 40 through 104 can be operated at multiple speeds with the addition of a solid-state control.

All units are available with 1140 rpm explosion-proof motors.

Vertical Unit Heaters

Steam Performance Data

STANDARD UNITS

Performance based on steam @ 2# at heater with air entering @ 60°F.

Unit No.	BTU Per Hour	Condensate LBS. Per Hour	Sq. Ft. EDR.	Final Temp.	Motor		CFM 70° F Air Basis	Outlet Velocity	Sound Rating
					H.P.	RPM			
VB-40	41,300	43	172	124	1/40	1550	595	877	I
	<i>33,600</i>	<i>55</i>	<i>140</i>	<i>131</i>		<i>1150</i>	<i>436</i>	<i>658</i>	
VB-62	65,500	68	273	121	1/20	1550	989	1005	II
	<i>52,800</i>	<i>55</i>	<i>220</i>	<i>129</i>		<i>1150</i>	<i>706</i>	<i>727</i>	
VB-77	80,600	83	336	122	1/20	1550	1200	1220	II
	<i>65,100</i>	<i>67</i>	<i>271</i>	<i>130</i>		<i>1150</i>	<i>858</i>	<i>894</i>	
VB-104	101,800	106	424	123	1/8	1070	1490	980	II
	<i>87,900</i>	<i>91</i>	<i>366</i>	<i>129</i>		<i>850</i>	<i>1180</i>	<i>783</i>	
VB-125	124,400	129	518	124	1/6	1100	1790	1170	III
VB-144	152,000	157	633	123	1/6	1100	2220	1045	III
VB-164	173,000	179	720	121	1/6	1100	2620	1230	IV
VB-200	210,200	208	838	118	1/4	1100	3200	1495	III
VB-237	249,800	260	1040	115	1/4	1100	4180	1205	IV
VB-285	283,800	294	1180	119	1/2	1100	4430	1275	IV
VB-317	333,400	345	1390	119	3/4	1140	5210	1500	IV
VB-367	386,000	400	1610	118	3/4	1140	6140	1770	IV
VB-495	496,000	514	2070	117	1-1/2	1160	8020	1640	IV
VB-585	585,000	605	2440	117	1-1/2	1160	9450	1930	IV
VB-700	705,000	729	2940	119	3	1165	11,000	2250	IV

NOTES:
Constant speed units are rated at capacities shown in regular type; capacities shown in italic faced type apply only to units with multi-speed motors.

**To determine BTU per hour capacities at various steam pressures and entering air temperatures, use conversion factors from table A, page 20.
Final temperatures at new conditions can be calculated by applying basic formula.

Vertical Unit Heaters

Steam Performance Data



LOW OUTPUT UNITS STANDARD MODEL "VB" UNITS WITH ALL AIR PORTS OPEN

Performance based on steam @ 2# at heater with air entering @ 60°F.

Unit No.	BTU Per Hour	Condensate LBS. Per Hour	Sq. Ft. EDR.	Final Temp.	Motor		CFM 70° F Air Basis	Outlet Velocity	Sound Rating
					H.P.	RPM			
VB-40L	34,800	36	145	108	1/40	1550	668	950	I
	<i>26,000</i>	<i>27</i>	<i>108</i>	<i>111</i>		<i>1150</i>	<i>470</i>	<i>672</i>	
VB-62L	57,200	59	238	104	1/20	1550	1200	1190	I
	<i>45,800</i>	<i>48</i>	<i>191</i>	<i>109</i>		<i>1150</i>	<i>862</i>	<i>858</i>	
VB-77L	68,000	71	283	106	1/20	1550	1360	1350	II
	<i>55,000</i>	<i>57</i>	<i>229</i>	<i>111</i>		<i>1150</i>	<i>995</i>	<i>992</i>	
VB-104L	85,400	89	356	108	1/8	1070	1640	1050	II
	<i>71,200</i>	<i>74</i>	<i>296</i>	<i>111</i>		<i>850</i>	<i>1290</i>	<i>827</i>	
VB-125L	111,000	115	462	107	1/6	1100	2180	1390	III
VB-144L	125,000	130	524	109	1/6	1100	2360	1080	III
VB-164L	149,000	154	620	107	1/6	1100	2920	1340	IV
VB-200L	176,800	183	736	108	1/4	1100	3390	1560	III
VB-237L	214,900	224	895	104	1/4	1100	4500	1270	IV
VB-285L	251,800	260	1050	106	1/2	1100	5040	1420	IV
VB-317L	291,000	302	1210	107	3/4	1140	5700	1610	IV
VB-367L	344,000	356	1430	108	3/4	1140	6600	1870	IV
VB-495L	428,000	446	1785	102	1-1/2	1160	9380	1860	IV
VB-585L	515,000	533	2140	106	1-1/2	1160	10,300	2060	IV
VB-700L	620,000	642	2580	108	3	1165	11,900	2380	IV

NOTES:

Constant speed units are rated at capacities shown in regular type; capacities shown in italic faced type apply only to units with multi-speed motors.

**To determine BTU per hour capacities at various steam pressures and entering air temperatures, use conversion factors from table A, page 20. Final temperatures at new conditions can be calculated by applying basic formula.

Steam Calculations and Correction Factors

		EXAMPLE: – UNIT: _____ VB-40 Steam Pressure _____ 10 PSI Entering Air Temp. _____ 40°F
I. CAPACITY		
A. For 2 lbs. steam, 60° entering air	Read output directly from table on p. 18: 41,300 BTU/HR.	
B. For higher steam pressures and/or E.A.T.'s above or below 60°F	Multiply output from table on p. 18 by appropriate correction factor from table A (below).	41,300 x 1.27 = 52,451 BTU/HR.
II. FINAL AIR TEMPERATURE		
A. For 2 lbs. steam, 60° entering air	Read temperature directly from table on p. 18: 124°F.	
B. For capacities calculated in I.B. (above)	$\frac{\text{Output from I.B.}}{1.085 \times \text{CFM from Table p. 18}} + \text{E.A.T.} = \text{Final Air Temp.}$	$\frac{52,451}{1.085 \times 595} + 40 = 121.0^\circ\text{F}$
III. FINAL AIR VOLUME		
A. For 2 lbs. steam, 60° entering air	$\frac{460 + \text{Final Air Temp from table on p. 18}}{530} \times \frac{\text{Nom. CFM from Table on p. 18}}{\text{Final Air Volume}} = \text{Air Volume}$	$\frac{460 + 124}{530} \times 595 = 655 \text{ CFM}$
B. For final air temperatures calculated in II. B. (above)	$\frac{460 + \text{Final Air Temp from II.B.}}{530} \times \frac{\text{Nom. CFM from Table on p. 18}}{\text{Final Air Volume}} = \text{Air Volume}$	$\frac{460 + 121}{530} \times 595 = 652 \text{ CFM}$
IV. CONDENSATE PER HOUR		
A. For 2 lbs. steam, 60° entering air	Read lbs. per hour from table on p. 18: 43 LBS./HR.	
B. For capacities calculated in I.B. (above)	$\frac{\text{Output from I.B.}}{\text{Latent Heat From Table B}} = \text{lbs. per hour of condensate}$	$\frac{52,451}{953} = 55.0 \text{ LBS./HR.}$

TABLE A — STEAM CORRECTION FACTORS BASED ON 2 LBS. STEAM 60° E.A.T.

ENTERING AIR TEMPERATURE	STEAM PRESSURE — LBS. PER SQ. IN. (SATURATED)									
	0	2	5	10	15	20	30	40	50	75
30°	1.18	1.22	1.27	1.34	1.40	1.45	1.53	1.61	1.67	1.79
40°	1.11	1.15	1.20	1.27	1.32	1.37	1.46	1.53	1.59	1.71
50°	1.03	1.07	1.12	1.19	1.25	1.30	1.39	1.46	1.52	1.64
60°	0.96	1.00	1.05	1.12	1.18	1.23	1.32	1.39	1.45	1.57
70°	0.90	0.93	0.98	1.05	1.11	1.16	1.25	1.32	1.38	1.49
80°	0.83	0.86	0.91	0.98	1.04	1.09	1.18	1.25	1.31	1.42
90°	0.76	0.80	0.85	0.91	0.97	1.02	1.11	1.18	1.24	1.36
100°	0.69	0.73	0.78	0.85	0.90	0.96	1.04	1.11	1.17	1.29

TABLE B — PROPERTIES OF SATURATED STEAM

	STEAM PRESSURE IN LBS. PER SQUARE INCH GAUGE									
	0	2	5	10	15	20	30	40	50	75
Steam Temperature-°F	212.0	218.5	227.1	239.4	249.8	258.8	274.0	286.7	297.7	319.9
Latent Heat of Steam	970	966	961	953	946	940	929	920	912	891

NOTE 1: Ratings apply only to free inlet and discharge without diffusers.

NOTE 3: For specific motor data refer to motor specifications on page 28.

NOTE 2: All motors are constant speed and operate at top speed as indicated in motor data. Models 40 through 104 can be run at reduced speed with addition of optional variable speed switch. This switch is factory-calibrated for low and high speed ratings, with intermediate speeds infinitely controllable. Models 164 through 700 operate at constant speed as indicated in motor data.

NOTE 4: To correct for entering air temperatures, use 1° temperature rise for each foot in mounting height. As an example, 60° air is required at work area (5 ft. above floor) units are to be mounted at (20 ft.) above floor. Mounting height (20 ft.) minus work height (5 ft.) equals differential (15 ft.) or, 15° rise in air temperature at unit air inlet. Correct for actual inlet air temperature of 75° (60° + 15° = 75° E.A.T.) on table A.

Vertical Unit Heaters

Hot Water Performance Data**



STANDARD OUTPUT UNITS

Model No.	Water Temp. Drop	Output MBH/HR	G.P.M.	H ₂ O Press. Drop	Final Air Temp.	Motor H.P.	R.P.M.	Nominal CFM	Outlet Velocity	Sound Rating
VB-40	10°	28.8	5.93	.37	104.6°	1/40	1550	595	877	I
	20°	22.7	2.34	.06	95.2°					
	30°	16.7	1.15	.02	85.9°					
VB-40*	10°	22.9	4.71	.24	108.3°	1/40	1150	436	658	I
	20°	18.1	1.87	.04	98.3°					
	30°	13.4	.92	.01	88.4°					
VB-62	10°	48.1	9.92	1.05	104.8°	1/20	1550	989	1005	II
	20°	39.6	4.08	.19	96.9°					
	30°	31.1	2.14	.06	89.0°					
VB-62*	10°	38.1	7.85	.67	109.7°	1/20	1150	706	727	II
	20°	31.5	3.24	.13	101.1°					
	30°	24.8	1.71	.04	92.4°					
VB-77	10°	58.7	12.11	.98	105.1°	1/20	1550	1200	1220	II
	20°	48.4	4.99	.18	97.2°					
	30°	38.1	2.62	.05	89.3°					
VB-77*	10°	46.5	9.59	.63	110.0°	1/20	1150	858	894	II
	20°	38.5	3.97	.12	101.2°					
	30°	30.5	2.09	.03	92.7°					
VB-104	10°	77.2	15.91	2.06	106.6°	1/8	1070	1528	980	II
	20°	68.3	7.03	.44	101.2°					
	30°	59.3	4.08	.16	95.8°					
VB-104*	10°	63.7	13.13	1.43	108.6°	1/8	850	1208	783	II
	20°	56.5	5.82	.31	103.1°					
	30°	49.2	3.38	.11	97.6°					
VB-125	10°	94.9	19.55	3.04	108.9°	1/6	1100	1790	1170	III
	20°	83.7	8.63	.65	103.1°					
	30°	72.5	4.98	.23	97.3°					
VB-144	10°	117.6	24.24	4.32	108.8°	1/6	1100	2220	1045	III
	20°	105.2	10.84	.96	103.7°					
	30°	92.8	6.38	.36	98.5°					

**Performance based on 200° EWT, 20° T.D., 60° E.A.T. Performance at 10° & 30° T.D. is also shown.
For capacities at other conditions, use the correction multipliers in the tables on page 25.

*Speed controller option is required for reduced ratings.

Vertical Unit Heaters

Hot Water Performance Data**

STANDARD OUTPUT UNITS

Model No.	Water Temp. Drop	Output MBH/HR	G.P.M.	H ₂ O Press. Drop	Final Air Temp.	Motor H.P.	R.P.M.	Nominal CFM	Outlet Velocity	Sound Rating
VB-164	10°	132.4	27.29	3.67	106.6°	1/6	1100	2620	1230	IV
	20°	118.6	12.22	.81	101.7°					
	30°	104.8	7.20	.30	96.9°					
VB-200	10°	156.2	32.20	5.02	105.0°	1/4	1100	3200	1495	III
	20°	139.7	14.40	1.11	100.2°					
	30°	123.2	8.47	.41	95.5°					
VB-237	15°	188.9	25.95	3.92	101.8°	1/4	1100	4162	1205	IV
	20°	180.1	18.56	2.10	99.9°					
	30°	162.7	11.18	.82	96.0°					
VB-285	15°	215.4	29.60	5.02	104.8°	1/2	1100	4430	1275	IV
	20°	205.4	21.17	2.68	102.7°					
	30°	185.3	12.73	1.04	98.5°					
VB-317	15°	254.9	35.03	6.88	105.1°	3/4	1140	5210	1500	IV
	20°	242.9	25.03	3.67	103.0°					
	30°	218.9	15.04	1.42	98.7°					
VB-367	15°	294.7	40.49	6.60	104.2°	3/4	1140	6140	1770	IV
	20°	280.8	28.94	3.52	102.2°					
	30°	253.1	17.39	1.36	98.0°					
VB-495	15°	—	—	—	—	1-1/2	1160	8020	1640	IV
	20°	368.1	37.93	5.81	102.3°					
	30°	333.6	22.92	2.29	98.3°					
VB-585	15°	451.2	62.00	8.78	104.0°	1-1/2	1160	9450	1930	IV
	20°	431.1	44.43	4.72	102.0°					
	30°	391.0	26.86	1.86	98.1°					
VB-700	15°	—	—	—	—	3	1165	11,000	2250	IV
	20°	519.4	53.52	5.29	103.5°					
	30°	470.9	32.35	2.08	99.5°					

**Performance based on 200° EWT, 20° T.D., 60° E.A.T. Performance at 10° & 30° T.D. is also shown.
For capacities at other conditions, use the correction multipliers in the tables on page 25.

Hot Water Performance Data**



LOW OUTPUT UNITS STANDARD MODEL "VB" UNITS WITH ALL AIR PORTS OPEN

Model No.	Water Temp. Drop	Output MBH/HR	G.P.M.	H ₂ O Press. Drop	Final Air Temp.	Motor H.P.	R.P.M.	Nominal CFM	Outlet Velocity	Sound Rating
VB-40L	10°	23.9	4.92	.26	92.9°	1/40	1550	668	950	I
	20°	18.9	1.95	.04	86.1°					
	30°	14.0	.96	.01	79.3°					
VB-40L*	10°	16.7	3.45	.13	92.8°	1/40	1150	470	672	I
	20°	13.5	1.39	.02	86.4°					
	30°	—	—	—	—					
VB-62L	10°	41.5	8.56	.80	91.9°	1/20	1550	1200	1190	II
	20°	34.2	3.53	.15	86.3°					
	30°	27.0	1.85	.04	80.7°					
VB-62L*	10°	32.4	6.68	.50	94.7°	1/20	1150	862	858	II
	20°	26.9	2.77	.09	88.7°					
	30°	21.3	1.46	.03	82.8°					
VB-77L	10°	48.9	10.09	.69	93.2°	1/20	1550	1360	1350	II
	20°	40.5	4.17	.13	87.4°					
	30°	32.0	2.20	.04	81.7°					
VB-77L*	10°	38.5	7.94	.44	95.7°	1/20	1150	995	992	II
	20°	32.0	3.29	.08	89.6°					
	30°	25.4	1.75	.02	83.5°					
VB-104L	10°	63.7	13.13	1.43	93.5°	1/8	1070	1752	1050	II
	20°	56.5	5.82	.31	89.7°					
	30°	49.2	3.38	.11	85.9°					
VB-104L*	10°	54.5	11.24	1.06	93.5°	1/8	850	1499	827	II
	20°	48.5	4.99	.23	89.8°					
	30°	42.4	2.91	.08	86.1°					
VB-125	10°	83.7	17.24	2.40	95.4°	1/6	1100	2180	1390	III
	20°	73.9	7.62	.51	91.3°					
	30°	64.2	4.41	.18	87.1°					
VB-144L	10°	95.4	19.66	2.92	97.3°	1/6	1100	2360	1080	III
	20°	85.5	8.81	.65	93.4°					
	30°	75.6	5.20	.24	89.5°					

**Performance based on 200° EWT, 20° T.D., 60° E.A.T. Performance at 10° & 30° T.D. is also shown.
For capacities at other conditions, use the correction multipliers in the tables on page 25.

*Speed controller option is required for reduced ratings.

Hot Water Performance Data**

LOW OUTPUT UNITS STANDARD MODEL "VB" UNITS WITH ALL AIR PORTS OPEN

Model No.	Water Temp. Drop	Output MBH/HR	G.P.M.	H ₂ O Press. Drop	Final Air Temp.	Motor H.P.	R.P.M.	Nominal CFM	Outlet Velocity	Sound Rating
VB-164L	10°	112.3	23.15	2.70	95.4°	1/6	1100	2920	1340	IV
	20°	100.7	10.38	.60	91.8°					
	30°	89.2	6.13	.22	88.1°					
VB-200L	10°	135.8	27.98	3.85	96.9°	1/4	1100	3390	1560	III
	20°	121.8	12.52	.85	93.0°					
	30°	107.3	7.37	.32	89.2°					
VB-237L	10°	168.5	34.72	6.75	94.5°	1/4	1100	4507	1270	IV
	20°	153.8	15.85	1.56	91.4°					
	30°	139.1	9.56	.61	88.4°					
VB-285L	10°	188.9	25.95	3.92	94.5°	1/2	1100	5040	1420	IV
	20°	180.1	18.56	2.10	92.9°					
	30°	162.7	11.18	.82	89.7°					
VB-317L	10°	220.9	30.35	5.26	95.7°	3/4	1140	5700	1610	IV
	20°	210.6	21.70	2.81	94.1°					
	30°	189.9	13.05	1.09	90.7°					
VB-367L	10°	260.7	35.82	5.24	96.4°	3/4	1140	6600	1870	IV
	20°	248.5	25.61	2.80	94.7°					
	30°	224.2	15.40	1.09	91.3°					
VB-495L	10°	—	—	—	—	1-1/2	1160	9380	1860	IV
	20°	310.5	32.00	4.23	90.5°					
	30°	281.7	19.35	1.67	87.7°					
VB-585L	10°	394.4	54.19	6.83	95.3°	1-1/2	1160	10,300	2060	IV
	20°	377.0	38.85	3.68	93.7°					
	30°	342.2	23.51	1.45	90.6°					
VB-700L	10°	—	—	—	—	3	1165	11,900	2380	IV
	20°	453.7	46.76	4.11	95.1°					
	30°	411.7	28.28	1.62	91.9°					

**Performance based on 200° EWT, 20° T.D., 60° E.A.T. Performance at 10° & 30° T.D. is also shown.
For capacities at other conditions, use the correction multipliers in the tables on page 25.

Vertical Unit Heaters Hot Water Calculations and Correction Factors



		EXAMPLE: – UNIT: _____ VB-40 Entering Water Temp. _____ 160°F Entering Air Temp. _____ 40°F Water Temperature Drop _____ 10°F
I. CAPACITY @ 20° TD: A. For 200° EWT, 60° EAT	Read output directly from tables on p. 21 - 24, 22,700 BTU/HR (Ref., Std. VB-40, 20° drop, p. 21).	
B. For EWT and/or EAT above or below Standard	Multiply output from table on p. 21 - 24 by factor from table A (below).	22,700 x .878 = 19,931 BTU/HR.
II. CAPACITY AT OTHER TD's A. For TD's from 5 to 60°F	Multiply output obtained in IA. or IB. (above) by appropriate factor from Table B (below)	IA - 22,700 x 1.15 = 26,105 BTU/HR. – OR – IB - 19,931 x 1.15 = 22,921 BTU/HR.
III. GPM AT OTHER TD's A. For TD's from 5 to 60°F	Multiply GPM of unit for 20° TD, from table on p. 21 by appropriate factor from table B (below).	2.34 x 2.30 = 5.38 GPM (Applies only to units with Std. 200° EWT, 60° EAT.) For all others calculate using formula – $GPM = \frac{BTU}{500 \times TD}$
IV. PRESSURE LOSS AT OTHER TD's A. For TD's from 5 to 60°F	Multiply P.D. of unit for 20° TD, from table on p. 21 - 24 by appropriate factor from table B (below).	.06 x 5.00 = .30 Ft. H ₂ O

TABLE A — HOT WATER CONVERSION FACTORS BASED ON 200° ENTERING WATER 60° ENTERING AIR 20° TEMPERATURE DROP

ENTERING AIR TEMPERATURE	ENTERING WATER TEMPERATURE — 20° WATER TEMPERATURE DROP										
	100°	120°	140°	160°	180°	200°	220°	240°	260°	280°	300°
30°	0.518	0.666	0.814	0.963	1.120	1.268	1.408	1.555	1.702	1.850	1.997
40°	0.439	0.585	0.731	0.878	1.025	1.172	1.317	1.464	1.609	1.755	1.908
50°	0.361	0.506	0.651	0.796	0.941	1.085	1.231	1.375	1.518	1.663	1.824
60°	0.286	0.429	0.571	0.715	0.857	1.000	1.143	1.286	1.429	1.571	1.717
70°	0.212	0.353	0.494	0.636	0.777	0.918	1.060	1.201	1.342	1.483	1.630
80°	0.140	0.279	0.419	0.558	0.698	0.837	0.977	1.117	1.257	1.397	1.545
90°	0.069	0.207	0.345	0.483	0.621	0.759	0.897	1.035	1.173	1.311	1.462
100°	0	0.137	0.273	0.409	0.546	0.682	0.818	0.955	1.094	1.230	1.371

To obtain the BTU capacity for conditions other than those in the basic capacity tables, multiply the basic rating (200° entering water, 60° entering air,) by the proper constant from the above tables.

TABLE B — HOT WATER BTU, GPM AND PRESSURE LOSS FACTORS BASED ON STANDARD CONDITIONS OF 200°F ENTERING WATER 60°F ENTERING AIR & 20°F WATER DROP

USE FACTORS FROM THIS TABLE TO OBTAIN APPROXIMATE RESULTS	TEMPERATURE DROP °F									
	5	10	15	20	25	30	40	50	60	
To obtain BTU for other Water Temperature Drops, multiply basic BTU rating by applicable Factor.	1.25	1.15	1.08	1.00	.94	.90	.83	.76	.72	
To obtain GPM for other Water Temperature Drops, multiply basic GPM rating by applicable Factor.*	5.00	2.30	1.44	1.00	.74	.59	.40	30	.24	
To obtain Pressure Loss Feet of Water for other temperature Drops, multiply Basic loss at 20° drop by Factor.	10.00	5.00	2.00	1.00	.60	.40	.20	.13	.07	

***TABLE C — MINIMUM WATER FLOW — GPM**

MODEL No.	40	62	77	104	144	164	200	237	317	367
MIN. GPM	.55	.55	.55	.55	.82	.82	1.10	1.10	1.10	1.10

***TABLE D — HEATING CAPACITY FACTORS FOR VARIOUS RATES OF WATER FLOW**

% of Rated Water Flow	25%	50%	75%	100%	125%	150%	175%
Btu/Hr Heating Capacity	.80	.89	.96	1.00	1.04	1.07	1.10

Dimensional Data

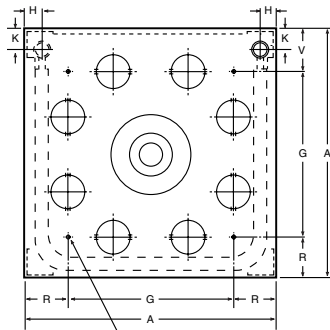

(4) MOUNTING HOLES 3/8" - 16 FOR MODELS 40-77
THREAD TAPS

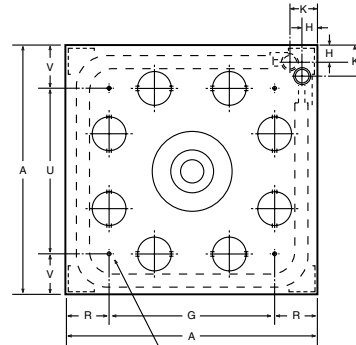

(4) MOUNTING HOLES 3/8" - 16 FOR MODELS 104-367
THREAD TAPS 1/2" - 13 FOR MODELS 495-700

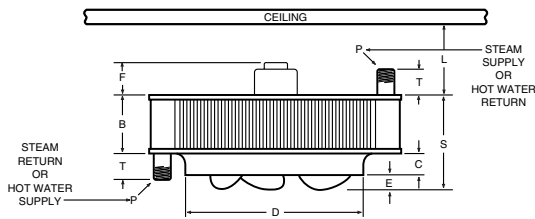

FIGURE A

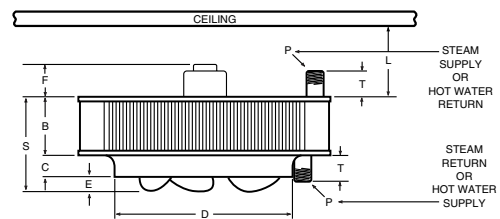

FIGURE B

FIGURE A — MODEL "VB" UNIT HEATER ROUGHING IN DIMENSIONS

Unit Size	Fan Dia.	A	B	C	D	E	F	G	H	K	L (Min.)	P (NPT)	R	S	T	U	V	Unit Wt. (lbs.)
40	11 ¹ / ₄	18 ³ / ₄	4 ⁵ / ₈	1 ¹ / ₄	11 ³ / ₄	3 ³ / ₄	4	11	1 ³ / ₈	1 ⁷ / ₈	7	1 ¹ / ₂	3 ⁵ / ₈	6 ⁵ / ₈	2 ³ / ₄	11	3 ⁵ / ₈	26
62	13 ¹ / ₂	21 ¹ / ₄	4 ⁵ / ₈	1 ⁵ / ₈	14	1	4	14	1 ³ / ₈	1 ⁷ / ₈	7	1 ¹ / ₂	3 ⁵ / ₈	7 ¹ / ₈	2 ³ / ₄	14	3 ⁵ / ₈	32
77	13 ¹ / ₂	21 ¹ / ₄	6 ¹ / ₈	1 ⁵ / ₈	14	1	3	14	1 ³ / ₈	1 ⁷ / ₈	7	1 ¹ / ₂	3 ⁵ / ₈	8 ⁵ / ₈	2 ³ / ₄	14	3 ⁵ / ₈	36

FIGURE B — MODEL "VB" UNIT HEATER ROUGHING IN DIMENSIONS

Unit Size	Fan Dia.	A	B	C	D	E	F	G	H	K	L (Min.)	P (NPT)	R	S	T	U	V	Unit Wt. (lbs.)
104	16 ³ / ₄	25 ¹ / ₄	6 ¹ / ₈	2	17 ¹ / ₂	1 ¹ / ₈	3	17	1 ³ / ₈	2 ³ / ₄	7	1 ¹ / ₂	4 ¹ / ₈	9 ¹ / ₈	2 ³ / ₄	17	4 ¹ / ₈	51
125	16 ³ / ₄	25 ¹ / ₄	6 ¹ / ₈	2	17 ¹ / ₂	1 ³ / ₄	3	17	1 ³ / ₈	2 ³ / ₄	7	1 ¹ / ₂	4 ¹ / ₈	9 ³ / ₄	2 ³ / ₄	17	4 ¹ / ₈	54
144	19 ³ / ₄	29 ¹ / ₂	6 ¹ / ₈	2 ³ / ₈	20 ⁵ / ₈	1 ¹ / ₄	4	20 ¹ / ₂	1 ³ / ₄	3 ¹ / ₂	7	2	4 ¹ / ₂	9 ⁵ / ₈	2 ³ / ₄	20 ¹ / ₂	4 ¹ / ₂	69
164	19 ³ / ₄	29 ¹ / ₂	6 ¹ / ₈	2 ³ / ₈	20 ⁵ / ₈	1 ³ / ₄	4	20 ¹ / ₂	1 ³ / ₄	3 ¹ / ₂	7	2	4 ¹ / ₂	10 ¹ / ₈	2 ³ / ₄	20 ¹ / ₂	4 ¹ / ₂	69
200	19 ³ / ₄	29 ¹ / ₂	7 ⁵ / ₈	2 ³ / ₈	20 ⁵ / ₈	2	4	20 ¹ / ₂	1 ³ / ₄	3 ¹ / ₂	7	2	4 ¹ / ₂	12	2 ³ / ₄	20 ¹ / ₂	4 ¹ / ₂	75
237	25 ¹ / ₄	37 ¹ / ₂	7 ⁵ / ₈	3	26 ³ / ₈	1	3 ¹ / ₂	28	1 ³ / ₄	3 ¹ / ₂	7	2	4 ³ / ₄	11 ⁵ / ₈	2 ³ / ₄	18	9 ³ / ₄	115
285	25 ¹ / ₄	37 ¹ / ₂	7 ⁵ / ₈	3	26 ³ / ₈	1 ¹ / ₄	3 ¹ / ₂	28	1 ³ / ₄	3 ¹ / ₂	7	2	4 ³ / ₄	11 ³ / ₄	2 ³ / ₄	18	9 ³ / ₄	120
317	25 ¹ / ₄	37 ¹ / ₂	7 ⁵ / ₈	3	26 ³ / ₈	2 ¹ / ₈	4	28	1 ³ / ₄	3 ¹ / ₂	7	2	4 ³ / ₄	12 ³ / ₄	2 ³ / ₄	18	9 ³ / ₄	120
367	25 ¹ / ₄	37 ¹ / ₂	9 ¹ / ₈	3	26 ³ / ₈	2	3 ¹ / ₂	28	1 ³ / ₄	3 ¹ / ₂	7	2	4 ³ / ₄	14 ¹ / ₈	2 ³ / ₄	18	9 ³ / ₄	126
495	30	42	9 ¹ / ₈	3 ¹ / ₂	31 ¹ / ₄	1 ⁵ / ₈	3	30	2 ¹ / ₄	4 ¹ / ₄	7	2 ¹ / ₂	6	14 ¹ / ₄	3	30	6	267
585	30	42	12 ¹ / ₈	3 ¹ / ₂	31 ¹ / ₄	2 ¹ / ₈	3	30	2 ¹ / ₄	4 ¹ / ₄	7	2 ¹ / ₂	6	17 ³ / ₄	3	30	6	210
700	30	42	13 ⁵ / ₈	3 ¹ / ₂	31 ¹ / ₄	3	4	30	2 ¹ / ₄	4 ¹ / ₄	7	2 ¹ / ₂	6	20 ¹ / ₄	3	30	6	260

FIGURE C
CONE DIFFUSER ROUGHING IN DIMENSIONS

Unit Size	A	B	C	D	No. of Louvers
40	16 ¹ / ₂	14 ¹ / ₄	6 ¹ / ₂	2 ⁵ / ₈	8
62 & 77	20	17	8	3 ¹ / ₈	8
104 & 125	24 ¹ / ₄	21	9 ³ / ₄	3 ¹⁵ / ₁₆	8
144, 164 & 200	28 ³ / ₈	24 ³ / ₄	11 ¹ / ₂	4 ⁵ / ₈	8
237, 285, 317 & 367	35 ¹ / ₂	31 ¹ / ₂	13 ³ / ₄	4	12
495, 585, 700	41 ¹ / ₂	37 ¹ / ₄	17	4 ³ / ₄	12

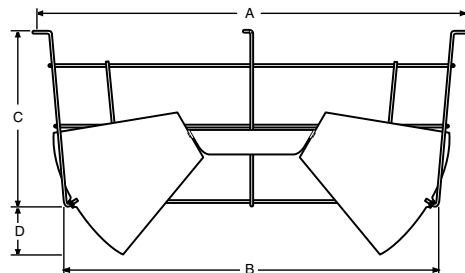

FIGURE C

Vertical Unit Heaters Mounting Heights & Throws, Technical Data



MAXIMUM MOUNTING HEIGHT IN FEET FOR MODEL "VB" UNIT HEATERS WITH AND WITHOUT LOUVER CONE DIFFUSER

Unit Size	Steam Pressure (PSI)					Unit Size	Steam Pressure (PSI)				
	2	5	10	50	75		2	5	10	50	75
VB-40	10.5 12.5	10.0 12.0	10.0 12.0	9.0 11.0	8.0 10.0	VB-144L	18.0 22.5	17.5 22.0	17.5 21.5	15.0 18.5	14.0 18.0
VB-40*	8.0 9.0	8.0 8.5	8.0 8.5	8.0 8.0	8.0 8.0	VB-164	18.0 22.5	17.5 22.0	17.0 21.5	14.5 19.0	14.0 18.0
VB-40L	12.5 14.5	12.0 14.0	12.0 13.5	10.5 12.0	9.5 11.5	VB-164L	22.0 27.5	21.5 27.0	21.0 26.5	18.5 23.5	17.5 22.5
VB-40L*	9.0 10.5	8.5 10.0	8.5 10.0	8.0 9.0	8.0 8.5	VB-200	22.0 27.5	21.5 27.0	21.0 26.5	18.5 24.0	17.5 23.0
VB-62	12.0 14.5	11.5 14.0	11.5 14.0	10.0 12.0	9.5 11.5	VB-200L	25.5 31.5	25.0 31.0	24.5 30.5	22.0 27.0	21.0 26.0
VB-62*	9.5 11.5	9.0 11.0	9.0 11.0	8.0 9.5	8.0 9.0	VB-237	20.0 25.0	19.5 24.0	19.0 23.5	17.0 20.5	16.0 19.5
VB-62L	15.0 19.0	14.5 18.5	14.5 18.5	12.5 16.5	12.0 16.0	VB-237L	24.0 29.5	23.5 28.5	23.0 28.0	20.0 24.5	19.0 23.5
VB-62L*	11.5 14.0	11.0 13.5	11.0 13.5	9.5 12.0	8.0 11.5	VB-285	21.0 26.0	20.5 25.5	20.0 25.0	17.5 22.0	17.0 21.0
VB-77	15.0 18.5	14.5 18.0	14.0 17.5	12.0 15.5	11.5 13.5	VB-285L	25.5 32.0	25.0 31.0	24.5 30.0	21.0 26.0	20.0 25.0
VB-77*	11.0 13.5	10.5 13.0	10.5 13.0	9.0 11.5	8.5 11.0	VB-317	24.0 30.0	23.0 29.0	22.0 28.0	20.0 25.0	19.0 24.0
VB-77L	18.0 22.0	17.5 21.0	17.5 21.0	15.0 19.0	14.0 18.0	VB-317L	29.0 36.0	28.5 35.0	28.0 34.0	25.0 30.0	24.0 29.0
VB-77L*	13.0 17.0	12.5 16.5	12.0 16.0	11.0 14.0	10.5 13.5	VB-367	28.5 35.5	28.0 35.0	27.5 34.0	24.0 30.0	23.0 29.0
VB-104	14.0 17.0	13.5 16.5	13.0 16.0	11.5 14.0	11.0 13.5	VB-367L	32.5 41.0	31.5 40.0	30.5 39.0	27.5 35.0	26.5 33.5
VB-104*	11.0 13.5	10.5 13.0	10.5 13.0	9.5 12.0	9.0 11.5	VB-495	29.5 36.5	29.0 36.0	28.5 35.5	25.0 32.0	24.0 30.5
VB-104L	17.5 21.5	17.0 21.0	16.5 20.5	15.0 18.5	14.5 17.5	VB-495L	35.0 43.5	34.0 42.5	33.0 41.5	29.0 35.0	28.0 34.0
VB-104L*	15.0 18.5	14.5 18.0	14.5 18.0	13.0 16.0	12.5 15.0	VB-585	34.0 42.5	33.0 41.5	32.0 40.5	28.0 36.0	27.0 34.5
VB-125	16.0 19.5	15.5 19.0	15.5 18.5	14.0 17.0	13.5 16.0	VB-585L	37.0 46.5	36.0 45.5	35.0 44.5	31.0 39.0	30.0 37.0
VB-125L	21.0 26.0	20.5 25.5	20.0 25.0	17.5 22.5	17.0 21.5	VB-700	38.5 48.0	37.5 47.0	36.5 46.0	32.0 40.0	30.5 39.0
VB-144	15.5 19.0	15.0 18.5	14.5 18.0	13.0 16.0	12.0 15.5	VB-700L	42.5 53.0	41.5 52.0	40.5 51.0	35.0 44.0	33.5 42.0

NOTES:

- * = Low Speed
- L = Model "VB" low output model with all air ports open

Figures in bold face show maximum mounting height with louver cone diffusers set vertically.

To meet CSA and OSHA requirements, units mounted below 8 feet from floor must be equipped with an OSHA fan guard. Please see page 31 for ordering information.

Above table based on 60°F entering air temperature. In providing for the use of diffusers, it must be remembered that adjustment of a LCD to deflect air toward horizontal immediately lowers the mounting height limit.

MAXIMUM SPREAD IN FEET

Unit Size: VB-	40	62	77	104	125	144	164	200	237	285	317	367	495	585	700
Spread (Ft.)	15	17	20	24	26	27	28	32	35	37	45	50	54	57	60

NOTE: The "spread" is the diameter of the comfort zone at floor level. Projected by the Model "VB" unit without the louver cone diffuser. Based on two pounds steam pressure and 60°F entering air.

TECHNICAL DATA

Propylene Glycol, when sizing equipment for systems that will utilize a Propylene Glycol solution consider the factors shown on page 10.

Motor Characteristics

TOTALLY ENCLOSED MOTOR TYPE

VB Unit Model No.	AMP	MCA	HP	RPM
115/1/60				
40	1.23**	1.6	1/40*	1550
62, 77	2.1**	2.6	1/20*	1550
104	1.2**	1.5	1/8*	1070
125, 144, 164	2.3**	2.9	1/6	1100
200, 237	3.6**	4.5	1/4	1100
285	5.4**	6.8	1/2	1100
208-230/460/3/60				
40, 62, 77, 104, 125, 144, 164	0.98-1.1/0.55	1.2-1.4/0.7	1/6	1140
200, 237	1.2-1.4/0.7	1.5-1.8/0.9	1/4	1140
285	1.8-2.0/1.0	2.3-2.5/1.3	1/2	1140
317, 367	3.1-3.2/1.6	3.9-4.0/2.0	3/4	1140
495, 585	5.3-5.0/2.5	6.6-6.3/3.1	1-1/2	1160
700	9.9-9.8/4.9	12.4-12.3/6.1	3	1165
575/3/60				
40, 62, 77, 104, 125, 144, 164, 200, 237	0.6	0.8	1/3	1140
285	0.8	1.0	1/2	1140
317, 367	1.3	1.6	3/4	1140
495, 585	2.0	2.5	1-1/2	1160
700	3.8	4.7	3	1165

*Optional variable speed switch is available.

**These motors have automatic thermal overload protection or impedance protection.

NOTE 1: All motors are constant speed and operate at top speed as indicated in motor data. Models through 1/8 H.P. can be run at reduced speed with addition of optional variable speed switch. This switch is factory-calibrated for low and high speed ratings, with intermediate speeds infinitely controllable. Models 164 through 700 operate at constant speed as indicated in motor data.

NOTE 2: Stated draw is Full Load (FLA). AMP draw varies by motor manufacturer \pm .2 AMPS.

EXPLOSION PROOF WITH THERMAL OVERLOAD MOTOR TYPE

VB Unit Model No.	AMP	MCA	HP	RPM
115/1/60				
40, 62, 77, 104, 125 144, 164	3.8	4.8	1/6	1140
200, 237	4.4	5.5	1/4	1140
285	7.8	9.8	1/2	1140
208-230/460/3/60				
40, 62, 77, 104, 125 144, 164	1.0-1.0/0.5	1.3-1.3/0.6	1/6	1140
200, 237	1.1-1.1/0.55	1.4-1.4/0.7	1/4	1140
285	1.9/0.95***	2.4/1.2	1/2	1140
317, 367	3.1-3.2/1.6	3.9-4.0/2.0	3/4	1145
495, 585	5.0/2.5***	6.5/3.3	1-1/2	1150
700	10.0/5.0***	12.5/6.3	3	1150

*** These motors are 230/460 volts only.

CAUTION: Select appropriate AMP and MCA for the multiple voltage motors. For example, the AMP and MCA for Model 40 with a 230 volt Totally Enclosed motor is 1.1 and 1.4 respectively.

Horizontal and Vertical Unit Heater Piping and Installation

The illustrations below depict different typical piping configurations. Proper selection should be based on the operational characteristics of the source supply. For selection and sizing of piping, traps, filters and other piping specialties, ASHRAE guides and specialty manufacturer's literature should be consulted. We assume that the type and total design of systems has been selected or approved by a qualified engineer. The installation and service manual should be consulted for further information on installation, operation, drainage and system cleaning.

Piping and installation is typical for both horizontal and vertical unit heaters – except side connections (below right).

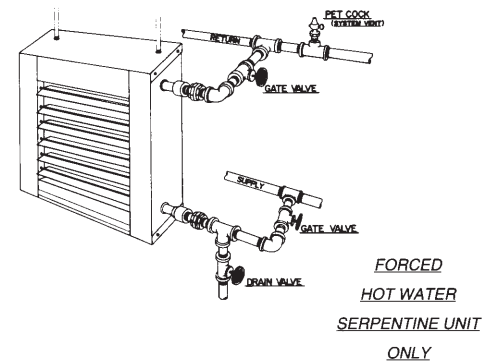
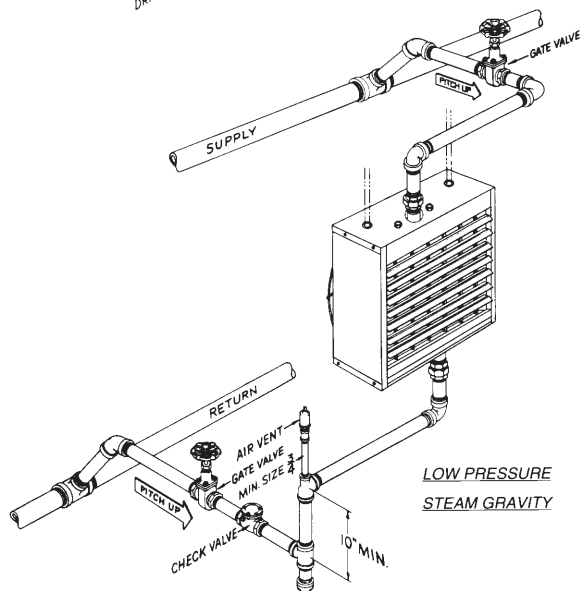
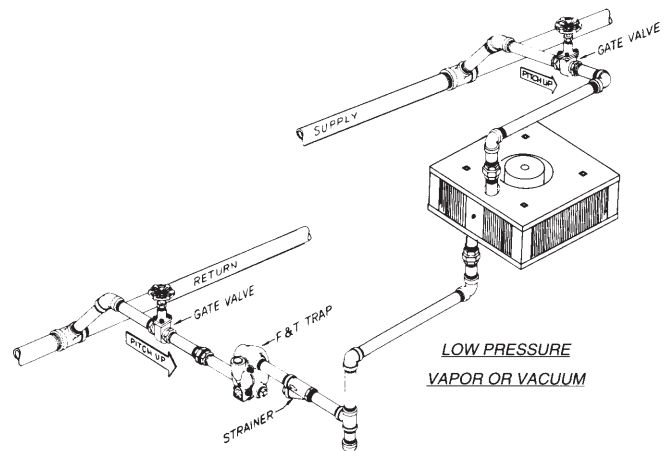
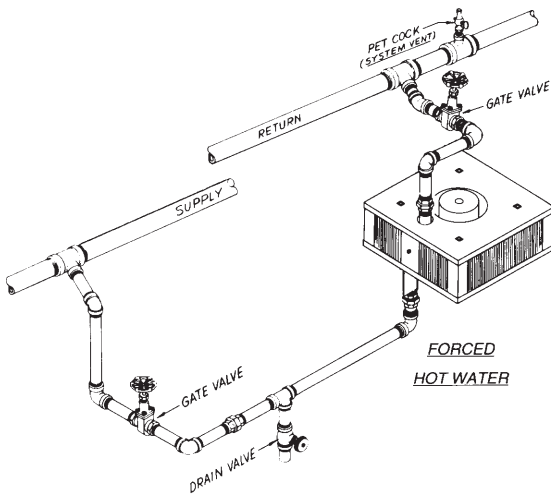
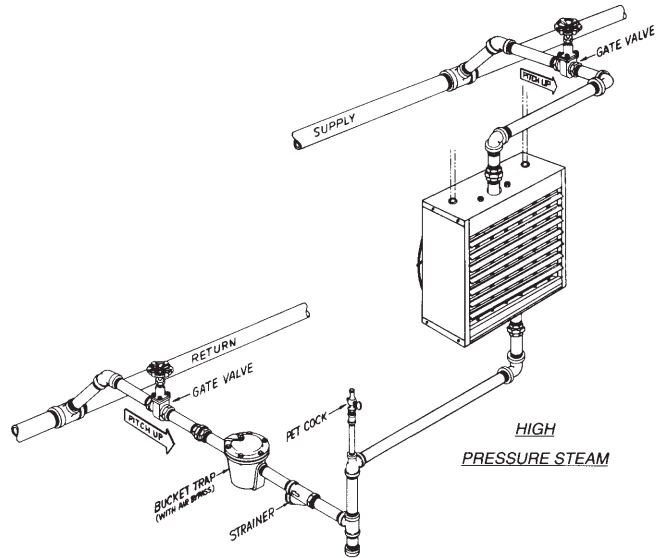

Wiring Diagrams and Warranty

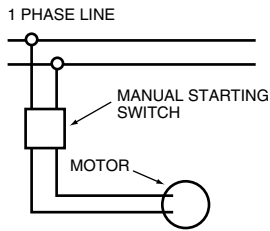

MANUAL CONTROL WITH SINGLE PHASE MOTOR

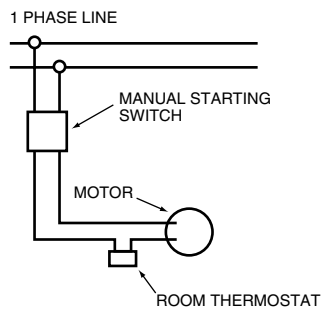

THERMOSTATIC CONTROL WITH MANUAL STARTER

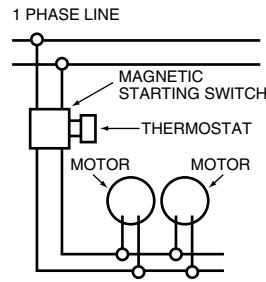

THERMOSTATIC CONTROL USING MAGNETIC STARTER OPERATING SEVERAL UNITS

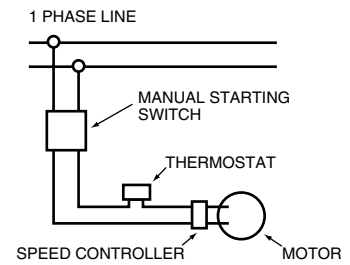

SPEED CONTROLLER WITH MANUAL STARTING SWITCH

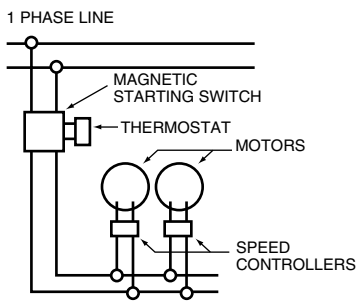

SPEED CONTROLLERS WITH MAGNETIC STARTING SWITCH FOR OPERATING SEVERAL UNITS

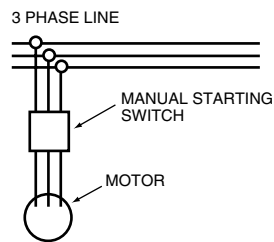

MANUAL CONTROL WITH THREE PHASE MOTOR

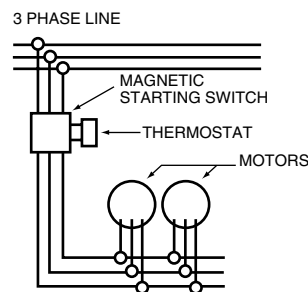

THERMOSTATIC CONTROL OF SEVERAL THREE PHASE UNITS

1. For internal wiring and overload protection on all starters, consult the control manufacturer for details.

2. When using thermostatic control with a manual starter, be sure that the electrical rating of the thermostat is sufficient to carry the motor current.

3. Refer to pages 16 and 28 for motor characteristics of individual unit heaters.

STEAM/HOT WATER UNIT HEATER WARRANTY

The products in this catalog are warranted by Beacon/Morris to be free from defects in material and workmanship for a period of one (1) year from the date of shipment from Beacon/Morris's plant. Beacon/Morris's liability under this warranty is limited to replacing or repairing at our option, F.O.B. our plant any defective component or assembly returned to our factory prepaid and with proper return authorization documents. All repairs or replacements are made subject to factory inspection. No liability is accepted for consequential damages, freight or labor charges.

This warranty does not cover damages or failure due to improper installation or piping, corrosive atmospheric conditions, misuse or negligence by others.

TERMS OF SALE

- No obligation is assumed by this corporation to sell to anyone holding this book any of the items listed herein.
- An order is not a valid order until acknowledged by Beacon/Morris.
- Beacon/Morris reserves the right to make changes in design, material or accessory vendors without notice and without obligation to incorporate such changes in products of prior manufacture.
- Additional sales and freight terms are contained in the price list.

HORIZONTAL HYDRONIC UNIT HEATERS

MODEL NUMBER DESCRIPTION

Digit	H	1	A	A	-	1	2	3	4	5	6	7	8	9	†
Item	Prefix					UT	CT	CA			SV	MT	AS		

(Internal use Only)

1, 2 - Unit Type [UT]

HB - Horizontal

3 - Coil Type [CT]

A - Serpentine

B - Standard (Header Type)

4, 5, 6 - Capacity [CA]

Coil Type [A] Serpentine*

108 - 8,030 BTU/HR 125 - 24,800 BTU/HR

118 - 18,400 BTU/HR 136 - 35,900 BTU/HR

*Based on 200° EWT, 60° EAT, 20° T.D.

Coil Type [B] Standard**

018 - 18,000 BTU/HR 132 - 132,000 BTU/HR

024 - 24,000 BTU/HR 144 - 144,000 BTU/HR

036 - 36,000 BTU/HR 156 - 156,000 BTU/HR

048 - 48,000 BTU/HR 180 - 180,000 BTU/HR

060 - 60,000 BTU/HR 204 - 204,000 BTU/HR

072 - 72,000 BTU/HR 240 - 240,000 BTU/HR

084 - 84,000 BTU/HR 280 - 280,000 BTU/HR

096 - 96,000 BTU/HR 300 - 300,000 BTU/HR

108 - 108,000 BTU/HR 360 - 360,000 BTU/HR

120 - 120,000 BTU/HR

**Based on 2 psi steam

7 - Supply Voltage [SV]

1 - 115/1/60 5 - 230/3/60

3 - 230/1/60 6 - 460/3/60

4 - 208/3/60 Z - Other

8 - Motor Type [MT]

1 - Standard Motor

2 - Explosion Proof

9 - Accessories [AS]

All Field Installed Accessories are to be entered as a separate line item using new catalog number which utilizes "AS" as a prefix. i.e: G6 becomes AS-G6.

FACTORY INSTALLED

M6 - OSHA Fan Guard (1 Phase Motor Only)

M9 - Standard Fan Guard

(3 Phase or Explosion Proof Motors Only)

V1 - Phenolic Coating (Air Dried)

V2 - Phenolic Coating (Baked)

FIELD INSTALLED (AS-____)

G6 - Locking Thermostat Cover

L2-1 - 115/230V Single Phase

Disconnect Switch - Unfused

L2-2 - 208/230V 3 Phase

Disconnect Switch - Unfused

L2-3 - 460/575V 3 Phase

Disconnect Switch - Unfused

Q6H - Vertical Louvers

U1 - Line Voltage Stat "Off/Auto Switch"

U2 - Line Voltage Stat "Auto/Off/Fan Switch"

U3 - Line Voltage Stat

"Auto/Off/Fan Switch Heavy Duty"

U4 - Celsius Line Voltage Thermostat

U5 - Strap on Hot Water Control

U6 - Steam Pressure Control

(Open on rise in pressure)

U7 - Steam Pressure Control

(Close on rise in pressure)

U8 - 5.0 Amp Speed Control Switch

(Capacities [CA] 18-108 Only)

U9 - Manual Starters - 1 Phase

U10 - Manual Starters - 3 Phase

VERTICAL HYDRONIC UNIT HEATERS

MODEL NUMBER DESCRIPTION

Digit	V	1	A	A	-	1	2	3	4	5	6	7	8	9	†
Item	Prefix					UT	CA	CA			SV	MT	AC		

(Internal use Only)

1, 2 - Unit Type [UT]

VB -Vertical

3 - Coil Type

B -Standard

4, 5, 6 - Capacity [CA]*

040 - 40,000 BTU/HR 237 - 237,000 BTU/HR

062 - 62,000 BTU/HR 285 - 285,000 BTU/HR

077 - 77,000 BTU/HR 317 - 317,000 BTU/HR

104 - 104,000 BTU/HR 367 - 367,000 BTU/HR

125 - 125,000 BTU/HR 495 - 495,000 BTU/HR

144 - 144,000 BTU/HR 585 - 585,000 BTU/HR

164 - 164,000 BTU/HR 700 - 700,000 BTU/HR

200 - 200,000 BTU/HR

*Based on 2 psi steam

7 - Supply Voltage [SV]

1 - 115/1/60 6 - 460/3/60

4 - 208/3/60 7 - 575/3/60

5 - 230/3/60 Z - Other

8 - Motor Type [MT]

1 - Standard

2 - Explosion Proof

9 - Accessories [AS]

All Field Installed Accessories are to be entered as a separate line item using new catalog number which utilizes "AS" as a prefix. i.e: G6 becomes AS-G6.

FACTORY INSTALLED

M6 - OSHA Fan Guard

V1 - Phenolic Coating (Air Dried)

V2 - Phenolic Coating (Baked)

FIELD INSTALLED (AS-____)

G6 - Locking Thermostat Cover

L2-1 - 115/230V Single Phase

Disconnect Switch - Unfused

L2-2 - 208/230V 3 Phase

Disconnect Switch - Unfused

L2-3 - 460/575V 3 Phase

Disconnect Switch - Unfused

Q8 - Louver Cone Diffuser

U4 - Celsius Line Voltage Thermostat

U5 - Strap on Hot Water Control

U6 - Steam Pressure Control

(Open on rise in pressure)

U7 - Steam Pressure Control

(Close on rise in pressure)

U8 - 5.0 Amp Speed Control Switch

(Capacities [CA] 040-104 Only)

U9 - Manual Starters - 1 Phase

U10 - Manual Starters - 3 Phase

W1 - T6169C Line Voltage Thermostat w/Subbase

(Light Duty)

W2 - T4051A Line Voltage Thermostat

(Heavy Duty)

W4 - Q651A1009 Stat Subbase Only

(Used with T4051A1003 for "Off/Auto Switch")

260 NORTH ELM STREET
WESTFIELD, MASSACHUSETTS 01085
(413) 562-5423 FAX: (413) 572-3764



 A MESTEK COMPANY
www.beacon-morris.com

7555 TRANMERE DRIVE
MISSISSAUGA, ONTARIO L5S 1L4 CANADA
(905) 672-2991 FAX (905) 672-2883