

# Instruction manual for installation, use and maintenance

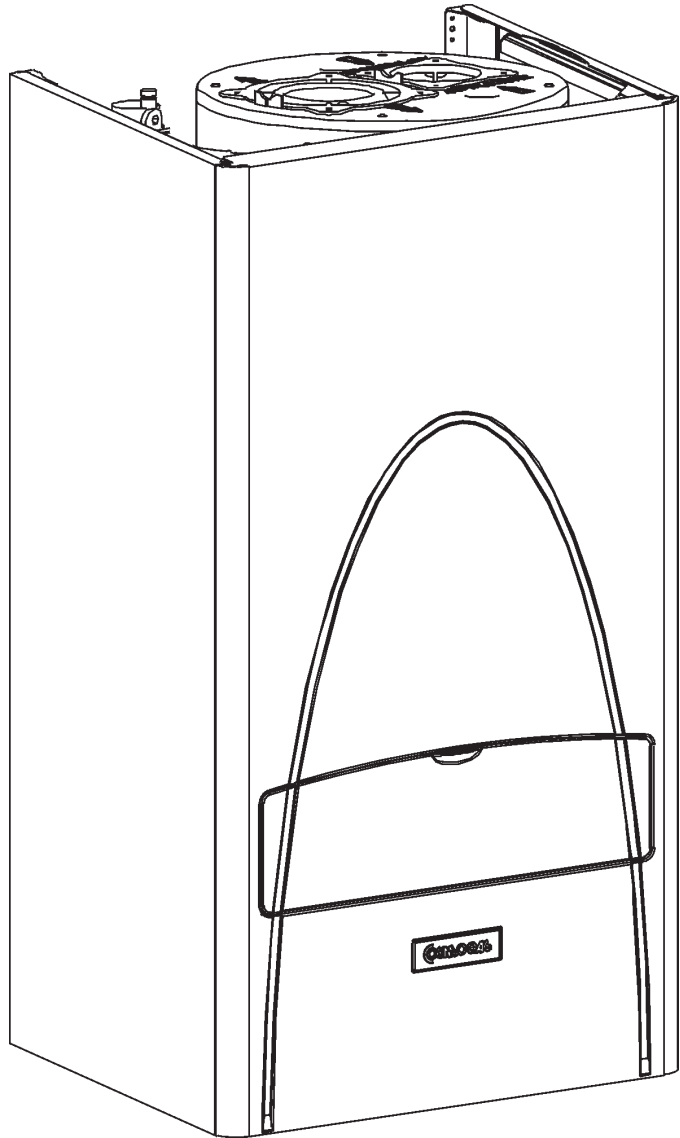

**MODELS:**

**AXIA 20E & AXIA 29E**

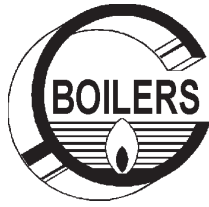

CSD-C-US



# SAFETY INSTRUCTIONS

**WARNING:** If the information in these instructions is not followed exactly, a fire or explosion may result causing property damage, personal injury or death.

- Do not store or use gasoline or other flammable vapors and liquids in the vicinity of this or any other appliance.
- **WHAT TO DO IF YOU SMELL GAS**
  - Do not try to light any appliance.
  - Do not touch any electrical switch; do not use any phone in your building.
  - Immediately call your gas supplier from a neighbor's phone. Follow the gas supplier's instructions.
  - If you cannot reach your gas supplier, call the fire department.
- Installation and service must be performed by a qualified installer, service agency or the gas supplier.



# SAFETY INSTRUCTIONS

- These instructions must be read prior to installation. If the information in these instructions is not followed exactly, a fire or explosion may result, causing property damage, personal injury, or death.
- **Hazards and Your Safety - Hot Water Can Scald!** Water temperature over **125°F (52°C)** can cause severe burns instantly, or death from scalds. Children, disabled, and elderly are at highest risk of being scalded; see instruction manual before setting temperature at water heater! Feel water before bathing or showering. Temperature limiting valves are available, see manual.
- **If there is a smell of gas:** Turn the gas cock off - Air the room - Do not try to light any appliances - Do not use any phone in your building - Do not touch any electrical switch - Extinguish any flames - Call immediately a licensed authorized technician or your local gas company - Follow the gas supplier's instructions - If you cannot reach your gas supplier, call the fire department.
- **If there is a smell of combustion products:** turn the unit off - Air the room - Call a licensed authorized technician.
- **Installation, alterations:** licensed authorized personnel must carry out the installation, calibration or alteration of the gas apparatus. Flue gas ducts must **not** be modified in any way. Any replaced part or packaging parts should never be left within reach of children.
- **Explosive products or easily inflammable products:** do not keep, use or store explosive materials or easily inflammable materials such as Gasoline, Adhesives, Solvents, Paint Thinner, Butane, Liquefied Propane, paper, etc., in the same room as the heater.
- **Maintenance:** the user, according to the heater's operating instructions, has to keep the installation in good condition and guarantee the reliable, safe operation of the heater. At least once a year the user must call in a licensed authorized technician for routine maintenance, before using it for central heating.
- **Servicing Manual:** when the installation and commissioning of the system has been completed, the installer should instruct the homeowner to save the installation manual near the heater so that service technicians may refer to it in the future.
- **Label all wires prior to disconnection** when servicing controls. Wiring errors can cause improper and dangerous operation. Verify proper operation after servicing.
- **Do not use this appliance** if any part has been under water. Immediately call a qualified service technician to inspect the appliance and to replace any part of the control system and any gas control, which has been under water.
- In the event of a breakdown and/or malfunction of the heater, turn off the unit and do not make any attempt to repair it. The heater must be serviced exclusively by a qualified technician. If it is necessary to replace any components, always use original spare parts. Failure to comply with this requirement may compromise the safety of the unit.
- This water heater must only be used for the purpose for which it has been expressly designed: heating of water for closed circuit systems for the central heating of civil and domestic buildings, production of domestic and sanitary hot water for civil use.
- The manufacturer declines all liability, contractual or otherwise, for damages resulting from incorrect installation or use of the heater, or from failure to comply with the instructions provided by the manufacturer, or from non compliance with the applicable local and national regulations in force.
- For safety and environmental reasons, the packing materials must be disposed of at the appropriate sorted refuse collection centres.
- Should overheating occur or the gas supply fail to shut off, turn off the gas valve service switch to the heater.

# TABLE OF CONTENTS

---

<b>1 - GENERAL INFORMATION</b> .....	<b>6</b>
1.1 - Key to the symbols used .....	6
1.2 - Warranty .....	6
<b>2 - GENERAL LAYOUT of the main components</b> .....	<b>7</b>
<b>3 - INSTALLATION</b> .....	<b>8</b>
3.1 - Pre-Installation .....	8
3.2 - Instructions for the user .....	8
3.3 - Clearances for installation .....	8
3.4 - Clearances from combustible material .....	8
3.5 - Choosing the place of installation .....	8
3.6 - Preparing to install the water heater .....	9
3.7 - Installation Template .....	9
3.8 - Supply and Return Piping .....	10
3.9 - Radiant Heating Installation .....	10
3.10 - Installation of two heaters .....	10
3.11 - Installation of three or more heaters .....	10
3.12 - Multi-zone system with several pumps .....	10
3.13 - Multi-zone System .....	10
3.14 - Internal electrical connection settings .....	10
3.15 - Use of glycol .....	10
3.16 - Domestic Hot and Cold water .....	10
3.17 - Water Hardness .....	11
3.18 - Gas supply .....	11
3.19 - Operating at high altitudes .....	11
3.20 - Connecting the supply, return, gas, cold water and hot water .....	12
3.21 - Safety relief valve .....	12
3.22 - Electrical connections .....	13
3.22.1 - Overview .....	13
3.22.2 - Choosing the room thermostat .....	13
3.22.3 - Connecting the room thermostat .....	13
3.22.4 - Connecting the power supply cable .....	14
3.22.5 - Functional electrical diagram .....	15
3.22.6 - Multiwire electric diagram .....	16
3.23 - Venting systems .....	17
3.23.1 - Rotation of the flue discharge/air intake fittings .....	18
3.23.2 - Kit for air intake/flue discharge .....	19
3.23.3 - 80/80 split system .....	20
3.23.4 - 80/80 split system: available accessories .....	21
3.23.5 - 80/80 split system: installation examples .....	22
3.23.6 - 60/100 coaxial system .....	23
3.23.7 - 60/100 coaxial system: available accessories .....	25
3.23.8 - 60/100 coaxial system: installation examples .....	26
3.23.9 - Combustion air supplied from inside .....	27
3.23.10 - Removing the condensation produced by flue gas discharge .....	28
3.24 - Water Connections .....	29
3.25 - Filling the heating system .....	40
3.26 - Ignition .....	40
3.27 - Regulating the domestic hot water .....	40
3.28 - Disassembling the cover panels .....	41

# TABLE OF CONTENTS

---

3.29 - Accessing the internal components .....	41
3.30 - Converting the burner to use a different type of gas .....	42
3.31 - Checking and adjusting the pressure of the gas supply .....	42
3.32 - Checking and adjusting the gas pressure at the burner .....	43
3.33 - Check CO2 level .....	43
3.34 - Adjusting the input rating to the required heat loss .....	44
3.35 - Adjust the input rating to the required maximum efficiency .....	44
<b>4 - MAINTENANCE .....</b>	<b>45</b>
4.1 - General cautions .....	45
4.2 - Cleaning the burner and the heat exchanger (flue-gas side) .....	45
4.3 - Burner flame .....	46
4.4 - Safety relief valves .....	46
4.5 - Flue gas discharge .....	46
4.6 - Combustible material .....	46
4.7 - Draining the heating side of the heater .....	46
4.8 - Draining the domestic side of the heater .....	46
<b>5 - USE .....</b>	<b>47</b>
5.1 - Control panel .....	48
5.2 - Ignition procedure .....	48
5.3 - Summer operation .....	48
5.4 - Winter operation .....	48
5.5 - Adjustments for winter operation .....	49
5.6 - Room thermostat .....	49
5.7 - Resetting the Ignition Module .....	49
5.8 - Low water cut-off device .....	49
5.9 - Manual Reset High-Limit Thermostat .....	49
5.10 - Heating Circulator Pump .....	49
5.11 - Temperature-Pressure gauge .....	49
5.12 - Gas valve service switch .....	49
5.13 - Shut-off procedure .....	49
5.14 - Precautions against freezing .....	50
5.15 - Flue gas discharge .....	50
5.16 - Abnormalities during operation .....	50
<b>6 - TROUBLESHOOTING .....</b>	<b>51</b>
6.1 - Troubleshooting Sequence of operation to light the burner .....	51
6.2 - Troubleshooting Sequence of Operation for a Call for Heat .....	52
6.3 - Troubleshooting Sequence of Operation for a Call for D.H.W. ....	52
<b>7 - SPARE PARTS .....</b>	<b>53</b>
<b>8 - TECHNICAL DATA .....</b>	<b>54</b>
8.1 - Table of the technical data .....	54
8.2 - Curves of residual head for central heating system .....	55
8.3 - Curves burner pressure-input rating .....	55
8.4 - Curves Efficiency-input rating .....	55

# 1 - GENERAL INFORMATION

---

This instruction manual refers to two types of heaters:

**AXIA 20E** - this appliance is a wall mounted, direct vent modulating space/water heater with input power rating from 51,180 Btu/hr (15 kW) to 90,000 Btu/hr (26.4 kW)

**AXIA 29E** - this appliance is a wall mounted, direct vent modulating space/water heater with input power rating from 99,000 Btu/hr (29 kW) to 157,000 Btu/hr (46 kW)

When referring to this instruction manual, be sure of which type of heater you are working with. This can be verified by referring to the data plate marked "Space water heater model". This data plate is located on the bottom side of the heater. Also verify the type of gas for which the heater is set. A label in the front of your heater states "NATURAL GAS", for heaters set to natural gas, or "LP GAS" for heaters set to LP gas.

## 1.1 - Key to the symbols used



**CAUTION!!! electrical shock!**

Failure to observe these precautions may compromise the correct operation of the appliance or cause serious injury to persons or animals, or damage to property.



**CAUTION!!! Generic danger !** Failure to observe these precautions may compromise the correct operation of the unit or cause serious injury to persons or animals, or damage to property.



**CAUTION!!!**

Important or necessary activity

## 1.2 - Warranty

Refer to the enclosed warranty card.

## 2 - GENERAL LAYOUT of the main components

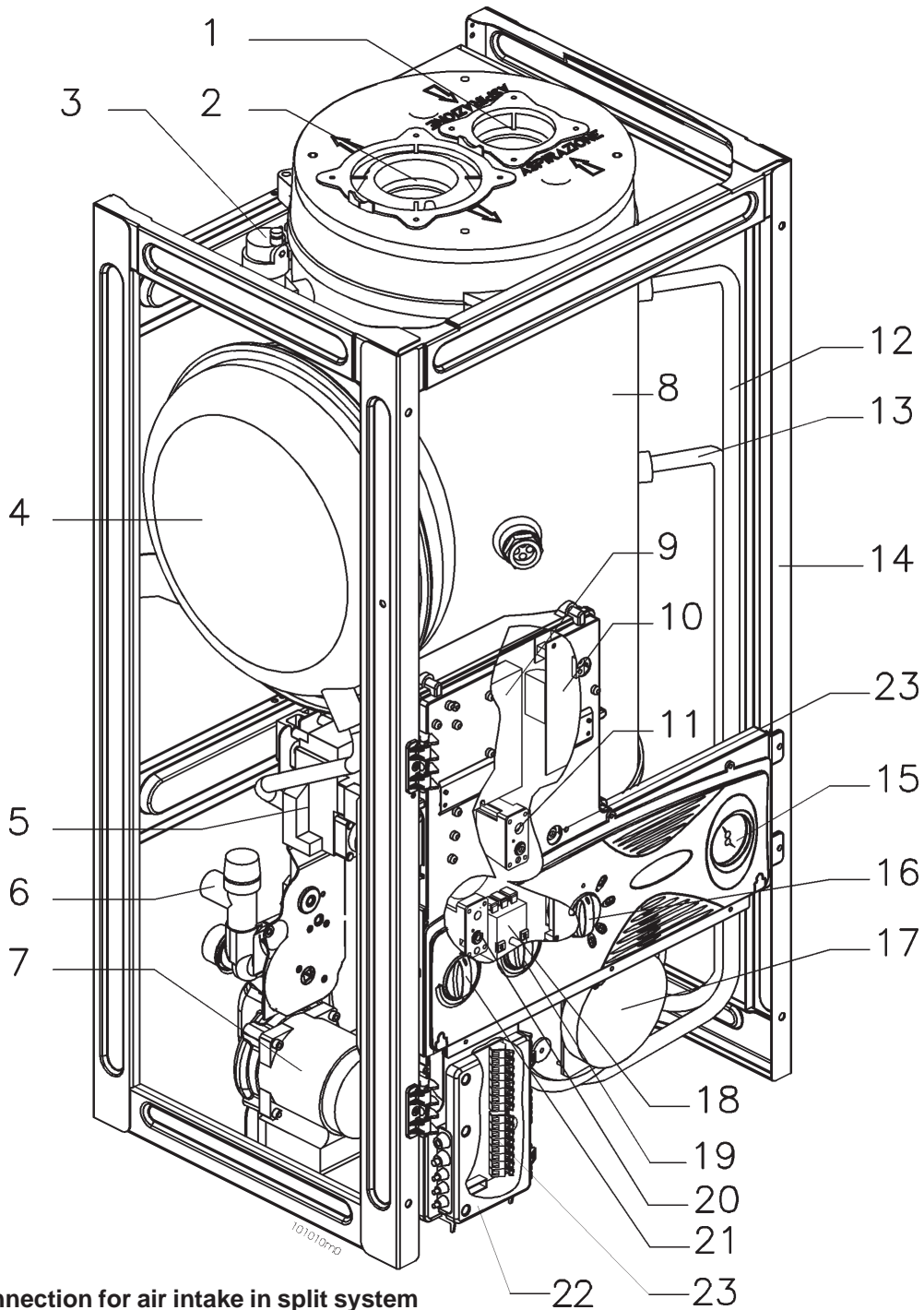

- 1 Connection for air intake in split system
- 2 Connection for coaxial pipe or for flue discharge in split system
- 3 Automatic air vent
- 4 Expansion tank
- 5 Gas valve
- 6 Safety relief valve
- 7 Circulator pump
- 8 Heat exchanger
- 9 Ignition module
- 10 Speed control board
- 11 Domestic hot water priority thermostat
- 12 Domestic hot water pipe
- 13 Domestic cold water pipe

- 14 Frame
- 15 Temperature-pressure gauge
- 16 Multifunction selector
- 17 Blower
- 18 Heater temperature control
- 20 High limit thermostat
- 21 Gas valve service switch
- 22 Junction box
- 23 Electrical control board
- 24 Cold start thermostat (optional)

Figure 1 - General layout of the main components

# 3 - INSTALLATION

## 3.1 - Pre-Installation

Installation must conform to the requirements of the authority having jurisdiction. In the absence of such requirements, installation must conform to:

**National Fuel Gas Code ANSI Z223.1/NFPA 54** and or **CSA B149.1, Natural Gas and Propane Installation Code.**

This appliance is designed for heating water to a temperature below its boiling point at atmospheric pressure.

- It must be hooked up to a heating system and to a sanitary hot water distribution system compatible with the characteristics, performance and power ratings of the water heater itself.
  - Before installation it is necessary to thoroughly flush the heating and plumbing systems, in order to remove any residues or impurities which may compromise the correct functioning of the water heater .
  - This water heater is not suitable for outside installation unless an outside installation kit is installed with the heater. .
- Choose a place that is protected from the atmospheric elements i.e. rain, wind, sun and especially frost, and which complies with the requirements prescribed by the applicable national and/or local regulations.
- Refer to figure 4 for the minimum clearance distances required for installation and subsequent servicing.

## 3.2 - Instructions for the user

The installer must instruct the user on the correct use of the water heater , and in particular must:

- supply the installation and user manual and all the documentation contained in the packing materials;
- instruct the user concerning the special measures to be taken for the discharge of flue gases, and inform the user that these must not be altered;
- inform the user concerning the

control of the water pressure necessary in the system and the necessary measures for filling and for purging;

- inform the user on how to correctly set the temperatures and room thermostats to conserve energy.

## 3.3 - Clearances for installation

Figure 4 shows the proper distances that are allowed for the support bracket and wall. (see figure 2)

## 3.4 - Clearances from combustible material

This appliance may be installed directly onto a wall of combustible material with the following clearance:

Ceiling	8 inches
Front	2 inches
Rear	0 inches
Sides	2 inches
Floor	8 inches

## 3.5 - Choosing the place of installation



**CAUTION!!!** The water heater must be installed on a vertical wall that is able to support its weight.

Heater may also be installed in a closet or alcove.

Choose a location centralized to the piping system with consideration to the vent pipe length. You will need to place the space/water heater so that the controls, drain, inlet/outlet, and gas valve are easily accessed. Care must be exercised when choosing the location of this appliance, where leakage from the safety relief valves, leakage from related piping, or connections, will not result in damage to the surrounding areas,

or to the lower floor of the building. Nothing should be installed between the safety relief valves and the heater. The discharge from the pressure relief valve must be connected to a suitable place for disposal. No reducing, coupling or other restrictions shall be installed in the discharge line. The discharge line should allow complete drainage of both valve and line.

Choose a suitable room and position for installation, taking the following factors into account:

- connection of the flue gas discharge/air intake pipes;
- connection of the gas supply piping;
- connection of the water supply;
- connection of the central heating system;
- connection of the sanitary hot water system;
- electrical connections;
- possible connection for draining the condensation produced by the flue gas discharge system;
- possible discharge connection for the safety relief valve.



## 3 - INSTALLATION

### 3.8 - Supply and Return Piping

The central heating supply and return pipes are marked with different colored caps, (supply red and return blue).

If the heater is to be connected to an existing system it is advisable to wash out and remove any deposits from inside the existing pipes, and install a filter at the lowest point to trap any additional impurities when it is running.

This equipment is designed for use in a closed loop system.

The pressure of the heating system side of the heater must be fitted with devices (automatic water feed/pressure reducing valve not to exceed 30 psi (2 bar)) adapted to function automatically in order to maintain the pressure of the heating side at a level below that of the potable water leaving the heat exchanger.

Installation schematics are found in figures 26 to 40.



**CAUTION!!!** All the schematics in figures 26 to 40 are only samples. Safety apparatus, pipe diameters, and auxiliary accessories must be verified by qualified personnel and in accordance with the national and/or local codes.

### 3.9 - Radiant Heating Installation

When the heater is used in conjunction with radiant heating, it is imperative that the tubing contains an oxygen diffusion barrier. If you are unsure whether or not the tubing has a barrier, a stainless steel plate heat exchanger must be used to protect the heater from oxygen corrosion (See figure 30). Oxygen corrosion will also occur if the heater is used in an open-loop system where new, cold-fill water is introduced into the system. The oxygen will remove itself from solution and react chemically with the ferrous components (i.e. steel), causing them to rust and corrode. **THIS TYPE OF FAILURE IS NOT COVERED BY THE**

WARRANTY!

### 3.10 - Installation of two heaters

To install two heaters in parallel, follow the diagram in figure 28.

### 3.11 - Installation of three or more heaters

Installing three or more heaters in parallel. Follow the diagram in figure 29.

### 3.12 - Multi-zone system with several pumps

When creating a multi-zone system with pump servicing the zone, it is necessary to isolate the operating pressure of the water heater circuit from the pressure of the heating system circuit. For this purpose, install a hydraulic disconnecter between the heater and the system (see fig. 31)

### 3.13 - Multi-zone System

When creating a multi-zone system it is necessary to follow the diagram shown in figure 32.

### 3.14 - Internal electrical connection settings

The water heater comes with a set of electrical terminals for a variety of system configurations, (inside junction box):

- relays for several pumps; the water heater is provided with terminals for connecting a relay that controls several pumps at the same time (see figure 35)

- plate heat exchanger; the water heater is provided with terminals for connecting and controlling a plate

heat exchanger for the production of domestic hot water or for a swimming pool (see figure 36)

- Indirect water heater; the heater is provided with terminals for connecting and controlling an indirect water heater (see figure 33) This function can also be combined with the relay function for multiple pumps (see figure 34)

- Cold start boiler; inside the junction box there are two terminals (see figure 7) marked with the numbers 5 and 6, connected together by a jumper. Simply remove this jumper to enable the heater to also function as a cold start boiler.

### 3.15 - Use of glycol

Toxic chemicals, such as those used for boiler treatment, shall not be introduced into the potable water used for space heating.



**CAUTION!!!** If a non-approved additive is used, it can cause serious health problems or possibly death.

If glycol is used with the heater, the glycol must be recognized as safe or approved by the United States Food and Drug Administration for food contact as listed in Code of Federal Regulations, title 21, part 182 of the Food Additive Regulations. Any additives introduced into the heating system **must** be recognized as safe by the United States Food and Drug Administration.

If glycol is used, it must be used in compliance with the product instructions. In any case, such substances should not be added directly inside the heater, but only through a radiator.

### 3.16 - Domestic Hot and Cold water

The domestic hot water flow restrictor must be installed on the cold water inlet, (Refer to figures 26, 27, 30, 31 and 32). For servicing purposes, install a shut-off valve upstream from the cold water inlet.

The heater's thermostat can be

### 3 - INSTALLATION

regulated to provide domestic hot water between 100°F (38°C) and 176°F (80°C).



**CAUTION!!!** Water

**temperature over 125°F (52°C) can cause severe burns instantly.** Since it is required that the heater water temperature reach above 140°F (60°C) in order for the heating system side of the unit to operate, it is **IMPERATIVE** that a mixing valve be installed external of the heater to further regulate the temperature of the domestic hot water (See figures 26, 27, 28, 30, 31, 32, 33, 36 and 36).



**CAUTION!!!** Failure to install

a domestic side mixing valve will result in severe burns!



**CAUTION!!!** Piping and

components for domestic hot and cold water, shall be suitable for use with potable water, and shall not be connected to any heating system or components previously used with a non-potable water heating appliance.



**CAUTION!!!** The domestic

hot water circuit needs an ASME approved pressure relief valve, set at 150 psi (10 bar), installed as close as possible to the heater. There must be no valves between the relief valve and the heater. The relief valve discharge pipe must not be restricted or plugged (see figure 26)

### 3.17 - Water Hardness

In hard water areas (above 150 p.p.m), it is recommended that a suitable water treatment device (softener with filters) be installed. Excessive buildup of minerals in the heat exchanger can cause a non-warranty failure. Water hardness can be determined by using the standard test or by checking with your local water authority.



**CAUTION!!!** Toxic

chemicals, such as those used for heater treatment, should not come into contact with the potable water used for space heating.

### 3.18 - Gas supply

Before making any gas connections, verify that the heater is being supplied with same gas type as indicated on the rating plate. The rating plate is located on the front panel of the heater.

There are two possible situations:

A – the gas and the supply pressure match the configuration of the heater. In this case, it is possible to proceed with connecting the heater;

B - the gas and supply pressure do not match the configuration of the water heater. In this case it is necessary to convert the heater for the type of gas and pressure of the available supply.

The conversion kit is supplied together with the water heater

- Install a manual gas cock outside

of the heater. Refer to figure 4, for the gas inlet location of the heater. Gas piping to the heater must be sufficient to guarantee a supply of gas to meet maximum requirements. See Table in chapter 8 for max. and min. values of gas pressure (Back of manual).

- All piping must comply with local codes and ordinances or with the National Fuel Gas Code, (ANSI Z223.1 NFPA No. 54), whichever applies.

- The appliance and its individual shutoff valve must be disconnected from the gas supply piping system during any pressure testing of that system at test pressures in excess of ½ psig, (3.5 kPa).

- The appliance must be isolated from the gas supply piping system by closing its individual manual shutoff valve during any pressure testing of the gas supply piping system at test pressures equal to or less than ½ psi, (3.5 kPa).

- The appliance and its gas connection must be leak tested before placing the appliance in operation.

- Before installation it is recommended to perform a thorough internal cleaning of the gas supply line. Figure 4 shows the positioning of the gas connection on the heater.

### 3.19 - Operating at high altitudes

For installations in the United States, the heater is rated for operation at altitudes up to 2000 ft (609 m). For installations at higher altitudes in the United States, follow local codes, or, in the absence of local codes, ANSI Z223.1/NFPA No. 54, The National Fuel Gas Code. For installations in Canada, the heater is rated for installations up to 4500 ft. For installations above this altitude, follow local/provincial codes.

Length of Gas Pipe	Capacity of Gas Pipe Size in kbtu/hr			
	1/2"	3/4"	1"	1 1/4"
10'	132	278	520	1050
20'	92	190	350	730
30'	73	152	285	590
40'	63	130	245	500
50'	\	115	215	440
75'	\	93	175	360
100'	\	79	150	305
150'	\	64	120	250
Additional length to be added for each bend or tee	1.3'	1.7'	2.2'	2.7'

TAB2AXIAUSA

# 3 - INSTALLATION

## 3.20 - Connecting the supply, return, gas, cold water and hot water

In its standard configuration, the heater comes with the fittings illustrated in figure 26.

More information about this matter are in the next pages

## 3.21 - Safety relief valve

An ASME approved safety relief valve, set at **30 psi (2 bar)**, is installed inside the heater.

If the safety relief valve discharges periodically, this may be due to thermal expansion in a closed water supply system.

**CAUTION!!! Do not plug the safety relief valve. There must be no valves between the relief valve and the heater. The relief valve discharge pipe must not be restricted or plugged.**

Connect the safety relief valve outlet "E" (see fig. 5) to pipe "F", (a 3/4" discharge pipe).

If the safety relief valve "E" (see fig. 5) is not connected to the discharge, opening of the valve may result in damage to persons, animals or property.

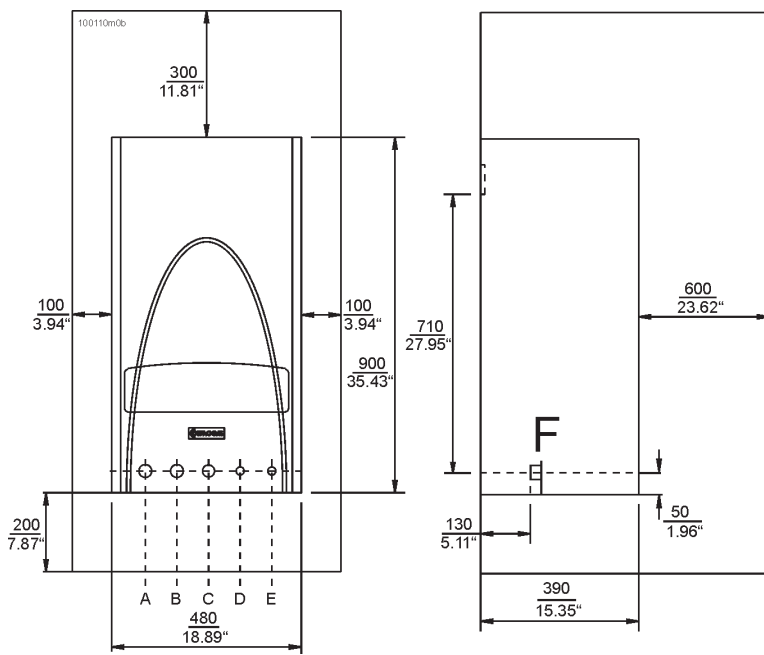

- A = domestic cold water
- B = domestic hot water
- C = gas
- D = heating return
- E = heating supply
- F = Position of the raccords

Figure 4 - Hydraulic and gas connections

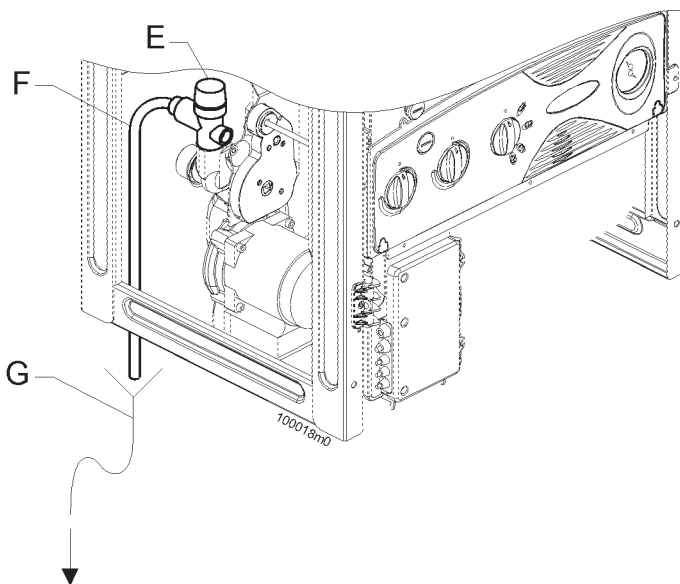

Figure 5 - Safety relief valve discharge connection

## 3 - INSTALLATION

### 3.22 - Electrical connections

#### 3.22.1 - Overview

If installing an external electrical source, the appliance must be electrically grounded in accordance with local codes or, in the absence of local codes, with the *National Electrical Code, ANSI/NFPA 70* and/or the *CSA C22.1, Electrical code*

The heater must be connected to a 115V 60Hz, single phase electrical supply fused to 15 amps, An electrical junction box (see figures 6, 7, 8) is provided for connections for both the line voltage of 115V 60 Hz..



**CAUTION!!!** Label all

wires prior to disconnection when servicing controls. Wiring errors can cause improper and dangerous operation. Verify proper operation after servicing.



**CAUTION!!!** The electrical

safety of the heater is assured only when it has been correctly connected to an efficient grounding system constructed in compliance with the safety regulations in effect. This is an essential safety requirement that must be verified. In case of doubt, have the electrical system thoroughly checked by a qualified technician;



**CAUTION!!!** If the heater is

not correctly connected to a grounding system, it will continually go into the lock-out state.

Have a qualified technician check that the electrical system is adequate for the electrical power, indicated on the rating plate, required by the heater.

The heater must be hooked up to the electrical supply by means of a fixed connection, (not with a removable plug), the use of adapters, multiple sockets or extensions is not permitted. Provide the installation of a main emergency switch immediately upstream from the heater.

Maintain the correct polarity between live and neutral when connecting the heater.

Ensure that the water and heating system pipes are not used as ground plates for the electrical or telephone system.

These pipes are not suitable for this purpose, and in addition this could rapidly lead to serious corrosion damage to the heater, pipes and radiators.

The heater is not provided with any protection against lightning strikes.

- connect the two ends of the cable to terminals 7 and 8;
- connect the cable, using a screwdriver to press down on the terminal block levers as shown in figure 8.

#### 3.22.2 - Choosing the room thermostat

The heater is designed to function with any type of room thermostat or programmable thermostat provided with contacts for connecting the heater cables, having the following characteristics:

- close = call for heating;
- open = don't call for heating
- not electrically supplied;
- minimum electrical characteristics  
24 Vac, 2.5A

#### 3.22.3 - Connecting the room thermostat

The room thermostat must always be located in a point of the house where the temperature is not subject to sudden changes.

To connect the wires of the room thermostat, proceed as follows (refer to figures 6, 7 and 8):

- use a two-core wire with a minimum cross section of 18 AWG;
- remove the heater front cover panel following the instructions given in chapter 3.28;
- back off the three screws "B" (see fig. 6) from box "A";
- open the door "A" (see fig. 6);
- choose a free cable clamp "C" (see figure 8) that is not used by other conductors;
- unscrew "D" screws (see fig. 8) of the cable clamp "C" and pass the cable inside;

### 3 - INSTALLATION

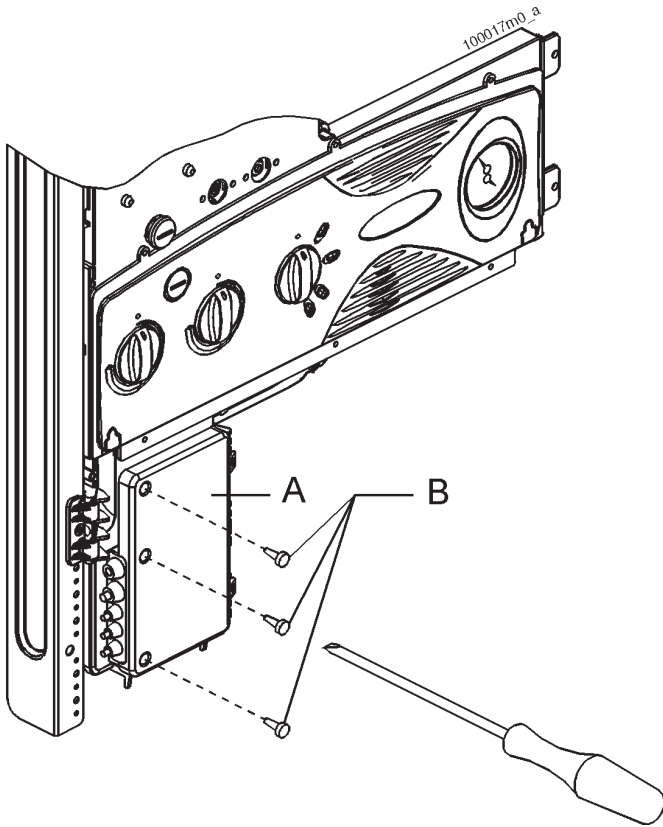

Figure 6 - Opening the electrical connection box

#### 3.22.4 - Connecting the power supply cable

To connect the electrical power cable, proceed as follows (refer to figures 6, 7, and 8):

- use a three-core cable with double isolation and a minimum cross section of 18 AWG (1.5 mm<sup>2</sup>);
- open the heater cover panels following the instructions given in chapter 3.28;
- unscrew the three screws "B" from box "A";
- open the door "A" as shown in figure 7;
- unscrew screws "C" + "D" on cable clamp and pass the cable inside;
- To connect the cables, use a screwdriver to push down on the levers of the terminal block as shown in figure 8.



**CAUTION!!!** if the "L1" live conductor is inverted with the "N" neutral conductor, the heater will go into the lock-out condition.



**CAUTION!!!** if the ground system is not efficient the heater will go into the lock-out condition.

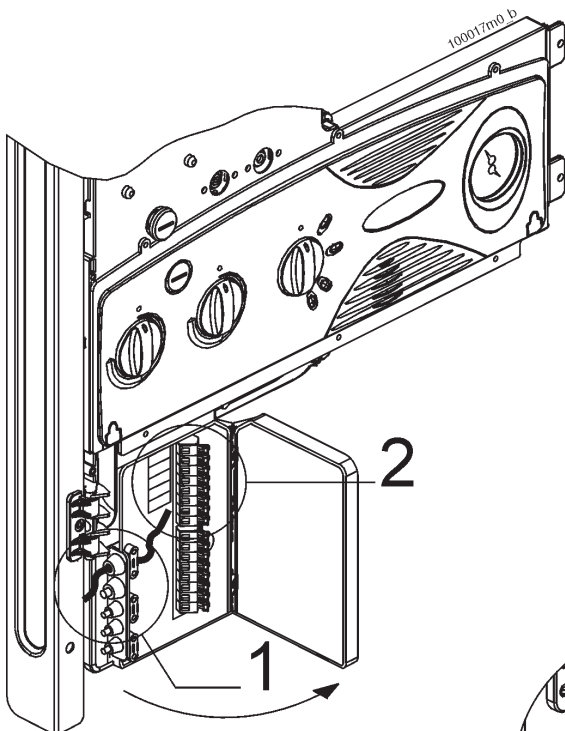

Figure 7 - Opening the junction box

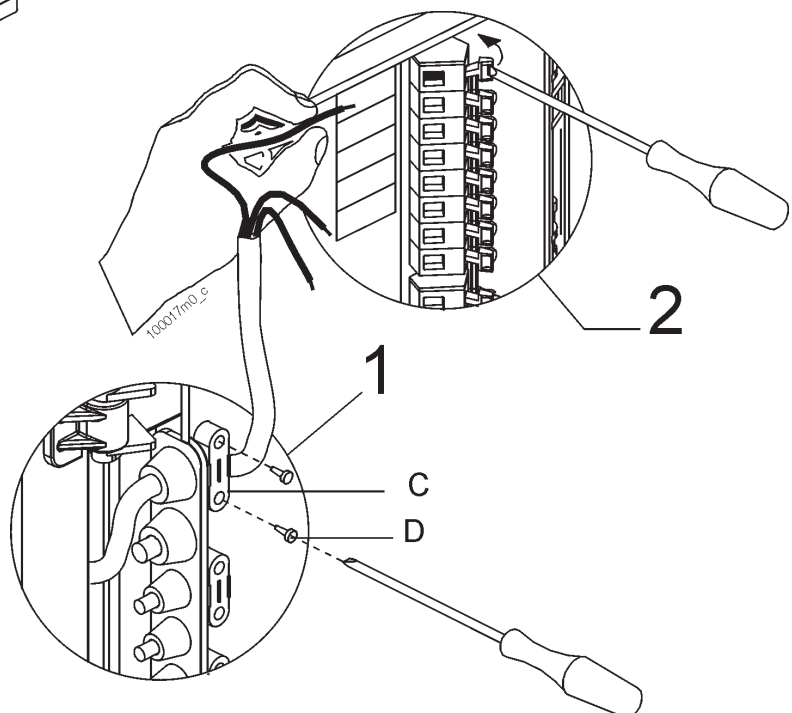
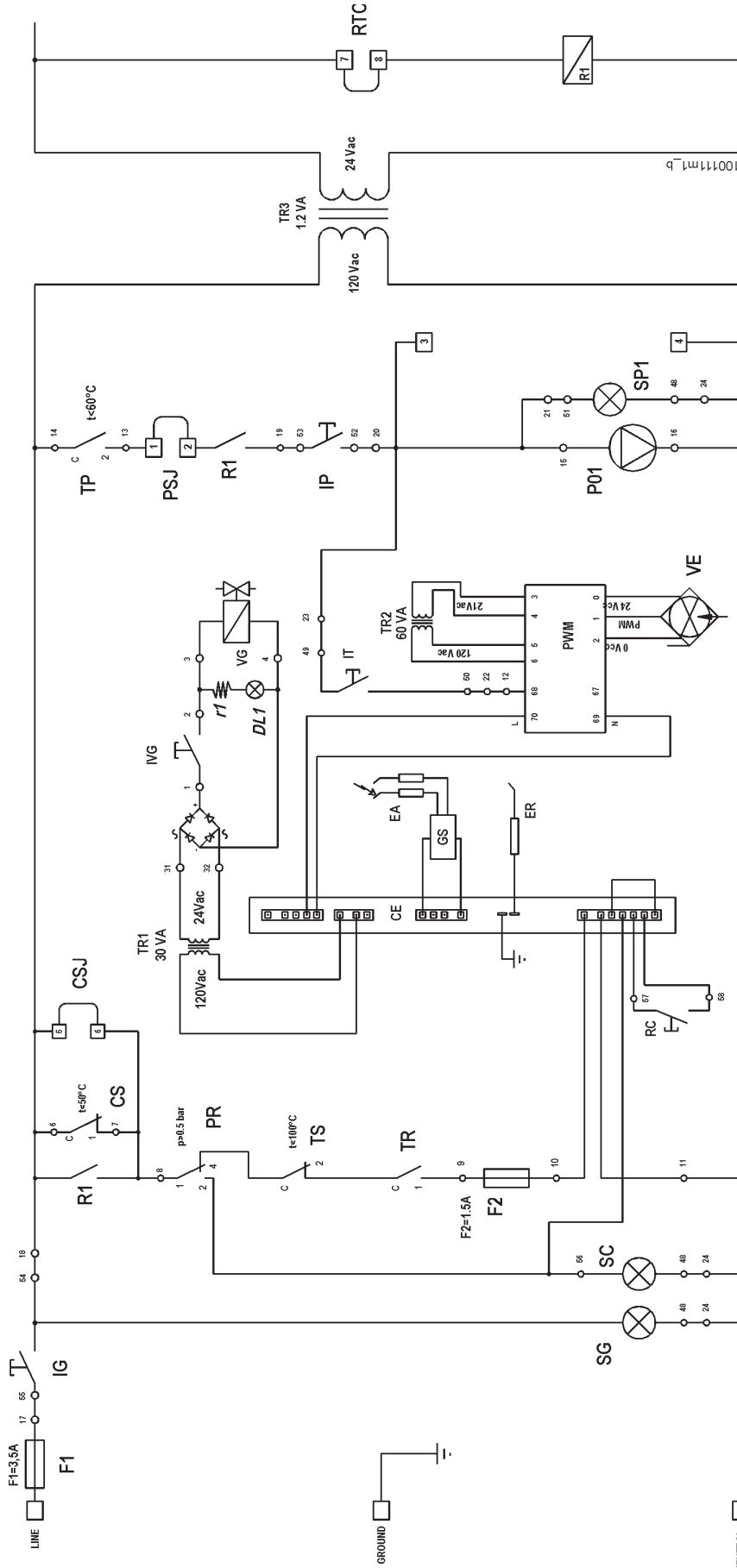

Figure 8 - Connecting the power supply

# 3 - INSTALLATION

## 3.22.5 - Functional electrical diagram



- CE = Ignition module
- CS = Thermostat for C.S.B. (optional)
- CSJ = Cold start boiler jump
- CB = Control board
- DL1 = Gas valve lamp
- EA = Ignition electrodes
- ER = Detection electrode
- F1 = Fuse
- F2 = Fuse
- GS = Sparks generator
- IG = Power switch
- IP = Heat and hot water selector
- IT = high or low power selector
- IVG = Gas valve service switch
- P01 = circulator pump
- PR = Low water cut-off
- PSJ = Connection for plate heat exchanger or indirect water heater
- PWM = Blower speed control
- R1 = Relay on control board
- RC = Reset for ignition module
- RTC = Room thermostat connection
- SB = switches board (multiselector)
- SC = Low water cut-off and lock out lamp
- SG = Electrical power lamp
- SP1 = circulator pump light
- TP = Domestic hot water priority thermostat
- TR = Heater temperature control
- TR1 = Transformer for gas valve
- TR2 = Transformer for blower
- TR3 = transformer for room thermostat circuit
- TS = High limit thermostat
- VE = Blower
- VG = Gas valve

# 3 - INSTALLATION

## 3.22.6 - Multiwire electric diagram

Legend: see chapter 3.22.5

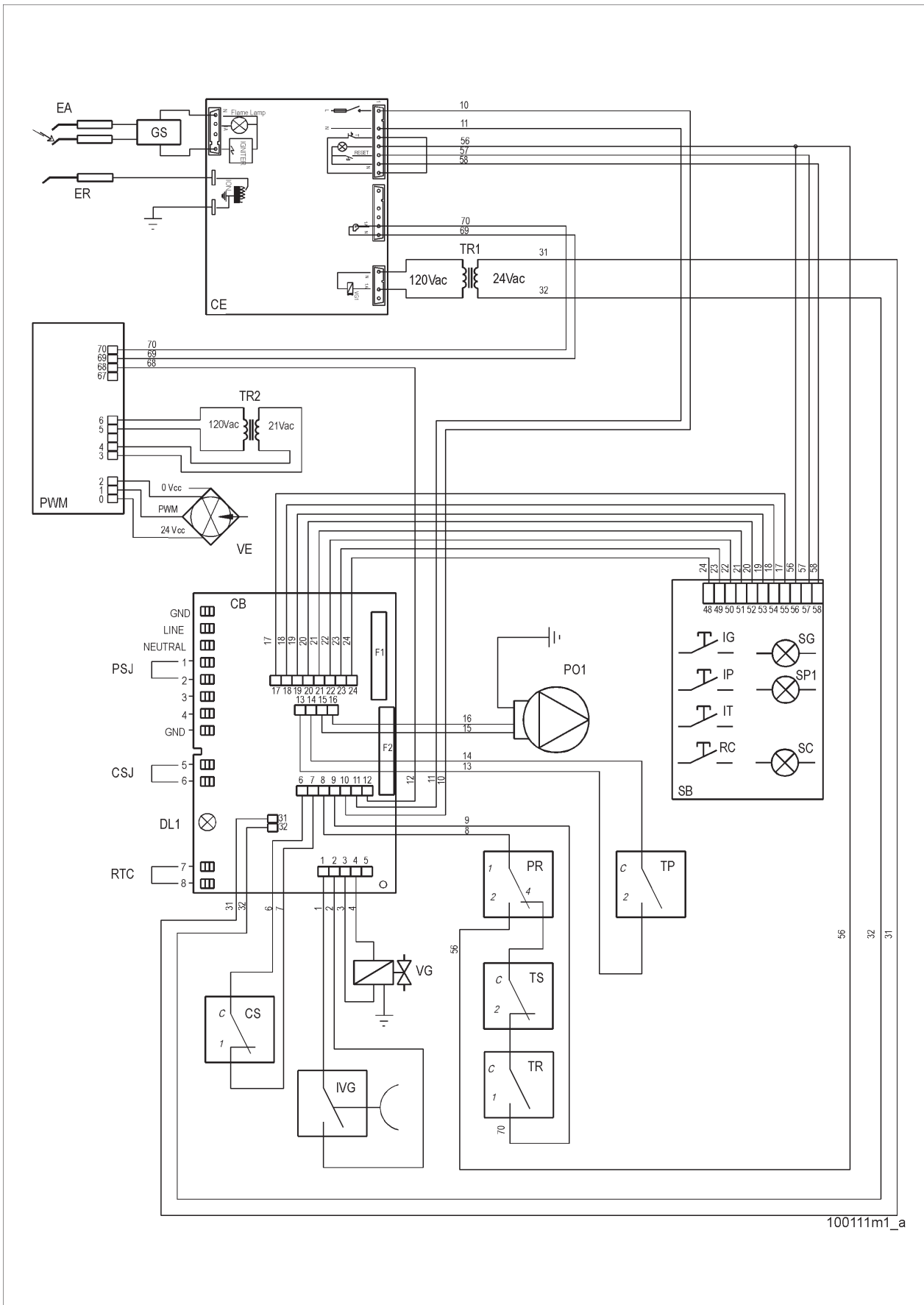

100111m1\_a

### 3 - INSTALLATION

### 3.23 - Venting systems

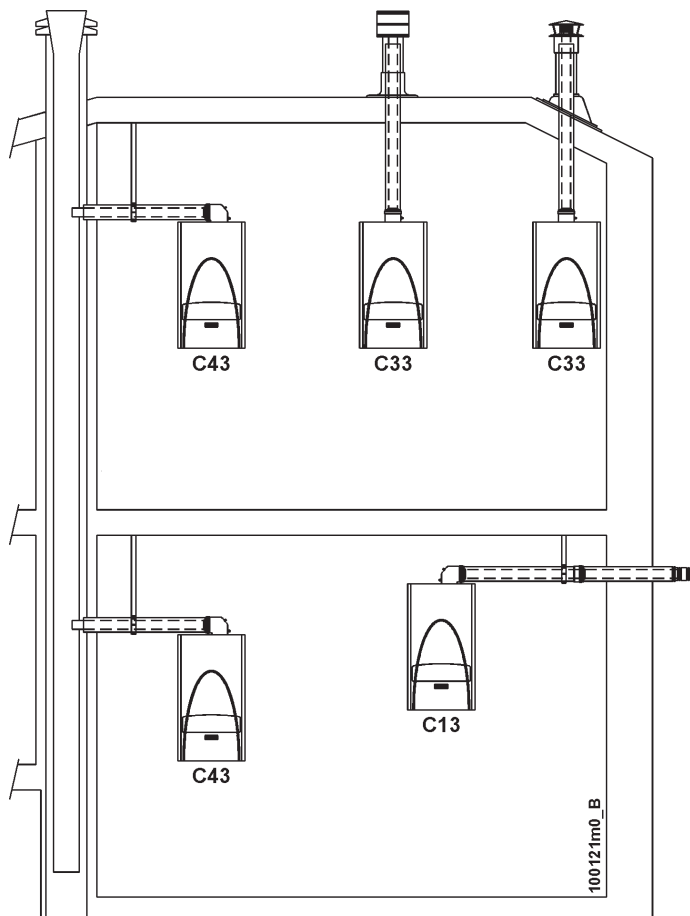
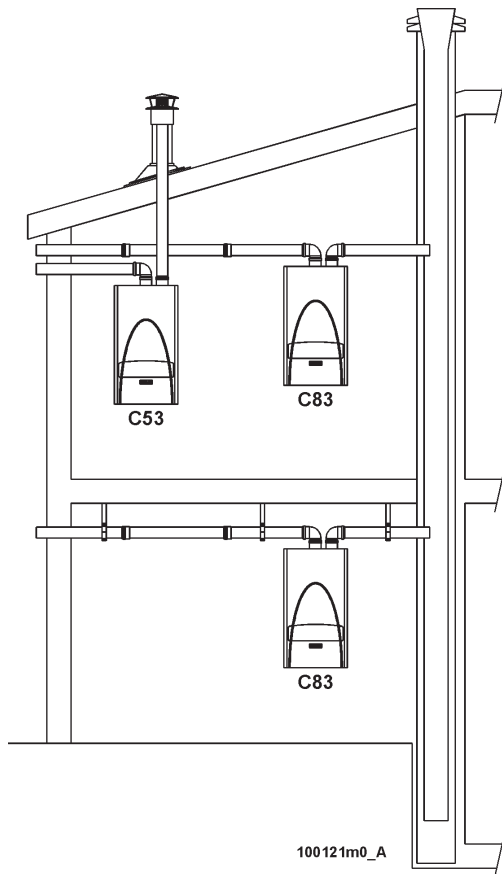

This heater can be fitted with either a concentric or split type venting system. The approved types of flue gas discharge configurations for this heater are shown in figure 9

Particular attention must be taken when installing the vent pipes that go through the wall to the outside. It must always be possible to carry out routine maintenance operations of the flue. The vent pipe must be installed in such a way that it can be removed, if needed, in the future. Hence, a suitable sheath should be prepared in which to insert the vent pipe. Both venting systems are suitable for venting through a wall 1" (25 mm) to 24" (609 mm) thick.

You must place the terminal in an open area, and follow the following guidelines:

- Make certain that exhaust gas does not re-circulate back into the intake pipe.
- To prevent anyone from walking into the exhaust vent, maintain a 7 ft (2.13 m) clearance from ground level in walkways, patio areas, alleys, or otherwise public areas.
- Maintain a minimum 3 ft (0.9 m) clearance from any window or doorway;
- Never install a heat saver or similar product to capture waste heat from exhaust;
- Follow local gas codes in your region or refer to National Fuel Gas Code, or Can B149.1 INSTALLATION CODES.
- Maintain at least 4ft (1.2 m) clearance to electric, gas meters and exhaust fans.
- Always place screens in openings (in intake and exhaust) to prevent foreign matter from entering the heater.
- The vent terminals, (concentric, split type exhaust), must be a minimum of 12" (0.3 m) above ground level.
- If split type vent will be venting into a chimney, make certain that no other appliances are vented into it. This power-vented heater must not share a chimney. Vent exhaust terminal should be inserted into, but not beyond, inner wall of chimney.
- Do not vent into transient pipe. **Warranty will be void.**
- Do not place vent terminal where flue products can cause corrosion.
- Due to the high efficiency of the heater, condensation may form in the discharge piping as a result of the cooling of the flue gases. It is therefore necessary to take every precaution to prevent this condensation from going inside the heater, by collecting it and conveying it outside the building. Follow the instructions for conveying the condensation provided in chapter 3.23.10.

Figure 9 - Approved types of flue gas discharge systems

## 3 - INSTALLATION

### 3.23.1 - Rotation of the flue discharge/air intake fittings

The connection of the flue pipes to the heater can be rotated through 360°, in increments of 90°. This makes it possible to choose between 4 different relative positions (see figure 10) of the discharge and intake pipes, allowing for great versatility of installation.

To carry out this operation (refer to figure 10):

- remove the fixing screws “A” from the top cover “B”.
- rotate the top cover to the desired position.
- reinsert the fixing screws “A” and lock them down without excessive force.

**Note:** “C” indicates the front of the heater in the top views.

In any position of rotation of the cover, the intake and discharge fittings can be rotated on themselves, allowing for optimal positioning of the connections for the combustion analysis and/or for the condensation discharge.

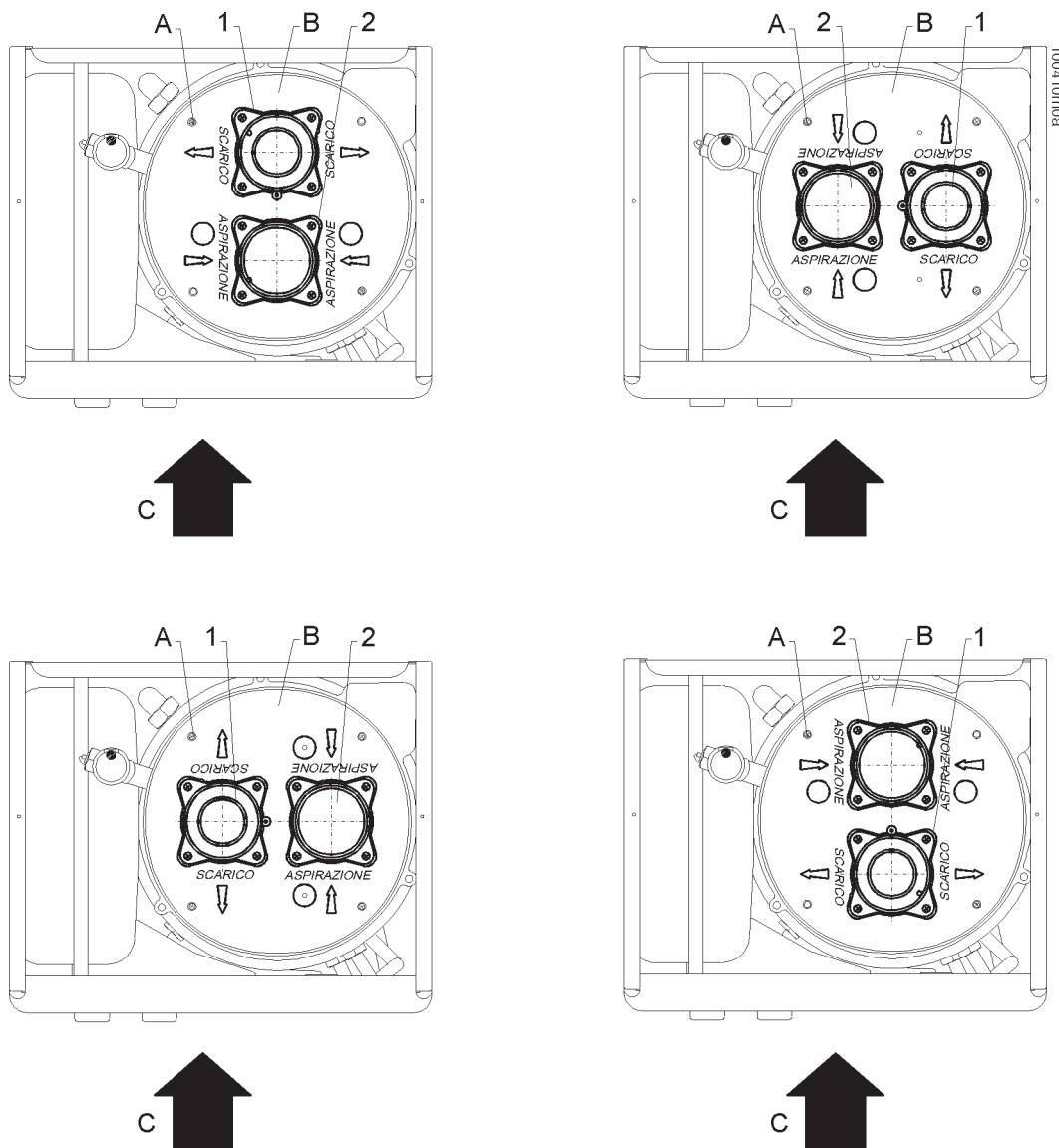

Figure 10 - Possibility of rotating the discharge and intake

## 3 - INSTALLATION

---

### 3.23.2 - Kit for air intake/flue discharge

To assist the installer, COSMOGAS has created flue kits, complete with all the necessary components for flue discharge and air intake. The four kits available are as follows:

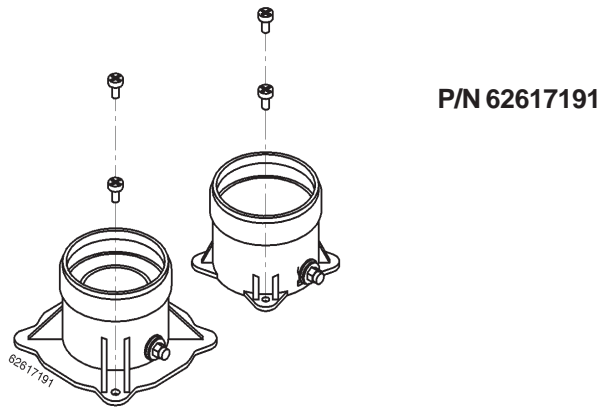

**P/N 62617191. Split vent kit.** This kit is used if you are taking the intake air from a different point than the flue gas discharge point. If you need additional extensions or elbows or other accessories, refer to figures 14, 15 and 16.

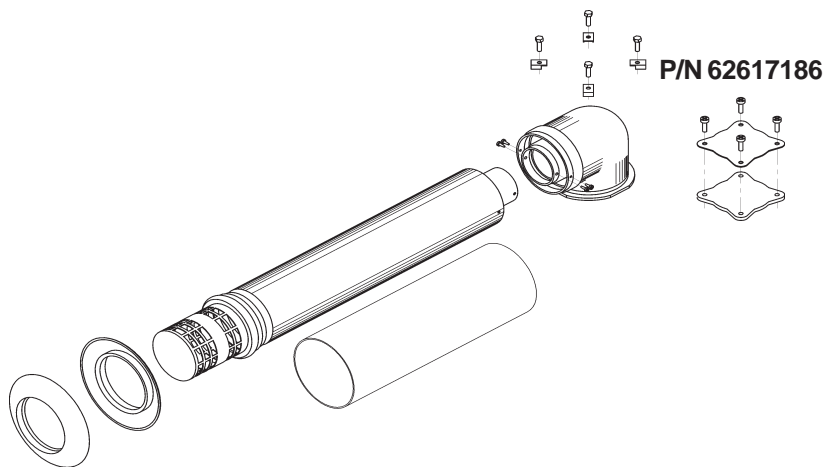

**P/N 62617186. Coaxial Vent & Elbow Kit.** This kit is used if you are taking in and discharging air from/to the outside of the building with a concentric vent. The pipe's discharge length is 3ft (1 m). If you need extensions, elbows or other accessories, refer to figure 22.

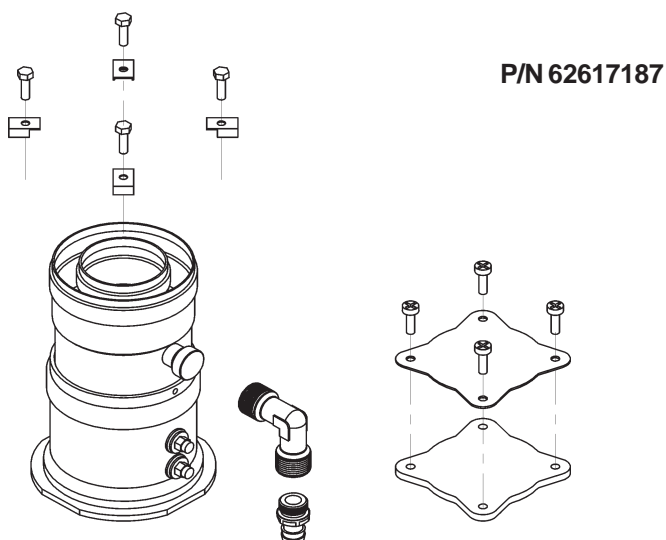

**P/N 62617187. Coaxial Vent & Straight Adapter Kit.** This kit is used to discharge air from/to the outside of the building. The pipe's discharge length is 3ft (1 m). If you need extensions, elbows or other accessories, refer to figure 23.

### 3 - INSTALLATION

#### 3.23.3 - 80/80 split system

The heater is not supplied with fittings for the flue gas discharge/air intake connections. To connect the heater to an 80/80 split system it is necessary to order the special kit and install it as shown in figure 11. On the flue gas discharge side, it is recommended to install stainless steel pipes which are more resistant to the formation of condensation. Take particular care with the installation of the pipe sections that pass through the wall to the outside; these must always allow for normal maintenance actions, therefore install the pipes inside a liner to enable them to be pulled out.

Make sure that vent pipe is pitched down from the unit toward the outside wall 1/4" (6 mm) per foot (0.3 m). This will prevent any water condensate from running back into the heater.

Also make sure that air intake pipe is pitched down from the unit toward the outside wall 1/4" (6 mm) per foot (0.3 m). This will prevent any water rain go into the heater. The heater is equipped with a condensation collector which, if used, must be connected to a discharge pipe (see fig. 12 details G, H, L, M). Details G, H, L, M are not supplied with the heater.

The condensation collector is designed to discharge the liquid produced by a single heater. If more than one heater is installed, each one must be equipped with its own condensation discharge pipe.

The flue gas discharge/air intake system can be extended up to the maximum distance indicated in chapter 8 at the end of the manual. Every 90° bend has an equivalent loss to 3ft (1 m) of straight piping. Every 45° bend has an equivalent loss to 1.5ft (0.5 m) of straight piping. If the air intake and flue gas discharge terminals are positioned on the same wall, they must be at a minimum distance of 3ft (1 m) from each other. The center line of the vent opening must be at least 12" (305 mm) above grade and at least 12" (305 mm) from

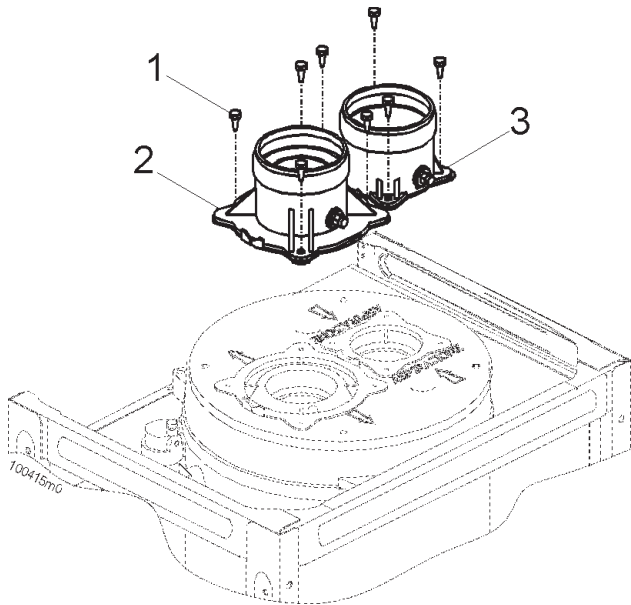

Figure 11 - Installation of the 80/80 split system

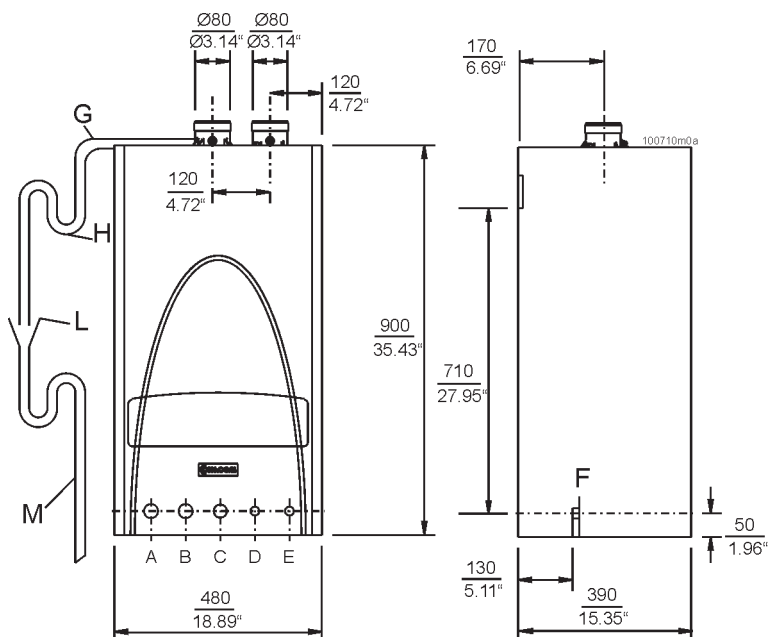

Figure 12 - Overall dimensions

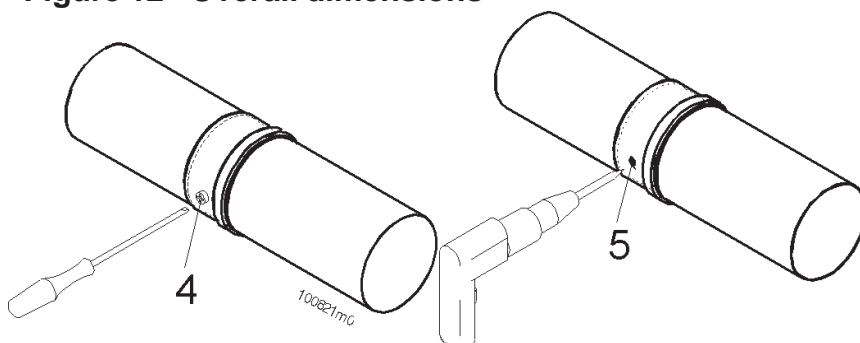

Figure 13 - Fixing of the flue gas discharge and air intake pipes

# 3 - INSTALLATION

any other building openings (doors, windows, etc.) Do not place vent terminal where flue products can cause corrosion.



**CAUTION!!! All venting MUST be secured with screws, and MUST be sealed from flue or air leakage, see figure 13.**



**CAUTION!!! The discharge vent temperature is above 250°F (121°C) while functioning, therefore it is essential that a thermal insulation protection sheath be used in the wall opening.**

## 3.23.4 - 80/80 split system: available accessories

Some of the most commonly used accessories for installing the split vent 80/80 flue gas discharge/air intake system are listed below (the number after the P/N is used to refer to the part in the following drawings)

- 62617086 - N°42 - 3ft (1000 mm) M/F extension in white painted aluminium;
- 62617058 - N°18 - 90° elbow M/F in white painted aluminium;
- 62617059 - 45° elbow M/F in aluminium, white
- 61302003 - intake grid in stainless steel
- 61302011 - N° 29 - Stainless steel roof terminal
- 61302004 - N° 30 - Horizontal discharge terminal
- 62617098 - N° 38 - T fitting in stainless steel
- 62617157 - N° 35 - condensation trap
- 60702011 - N° 48 - silicone washer

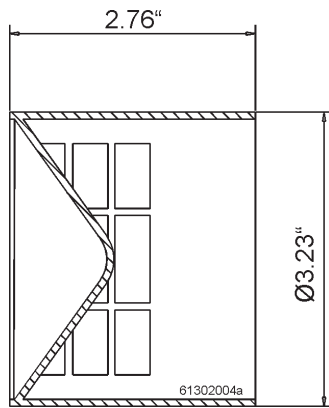

P/N 61302004

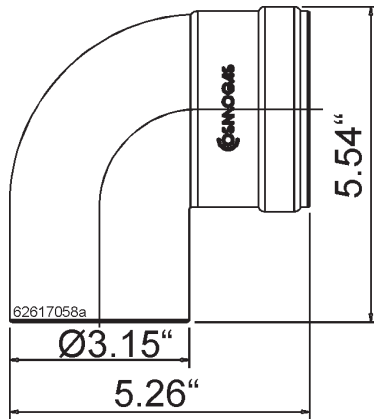

P/N 62617058

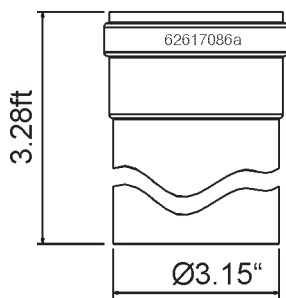

P/N 62617086

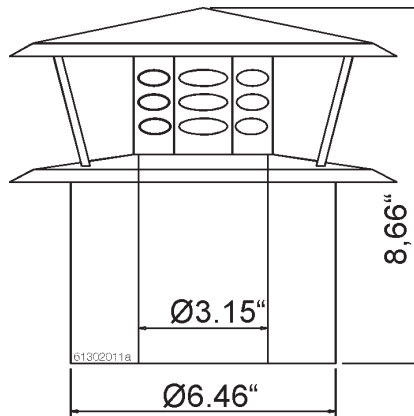

P/N 61302011

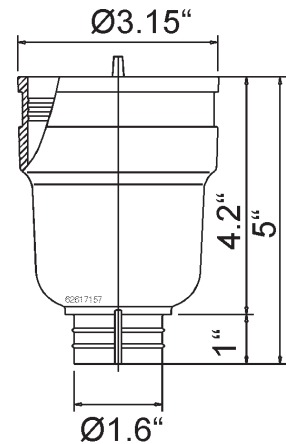

P/N 62617157

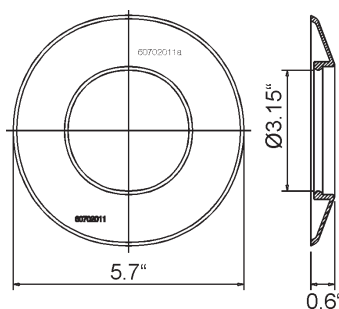

P/N 60702011

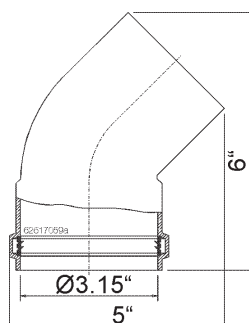

P/N 62617059

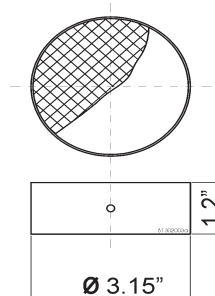

P/N 61302003

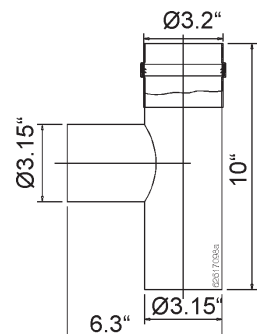

P/N 62617098

### 3 - INSTALLATION

#### 3.23.5 - 80/80 split system: installation examples

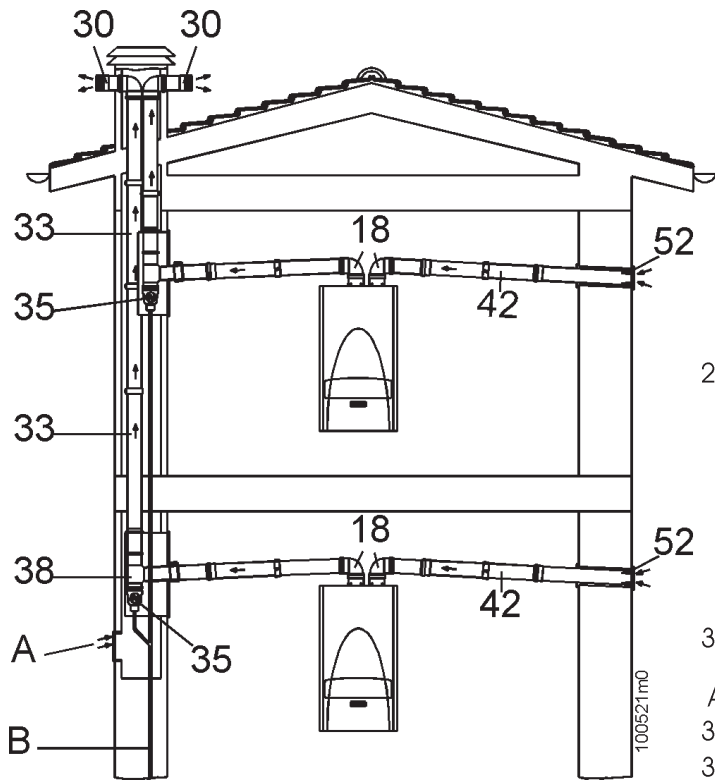

Figure 14 - Installation example

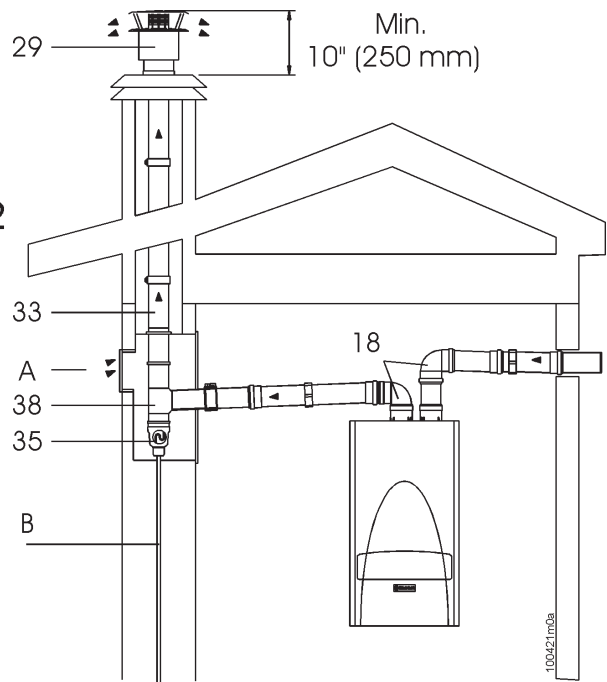

Figure 15 - Installation example

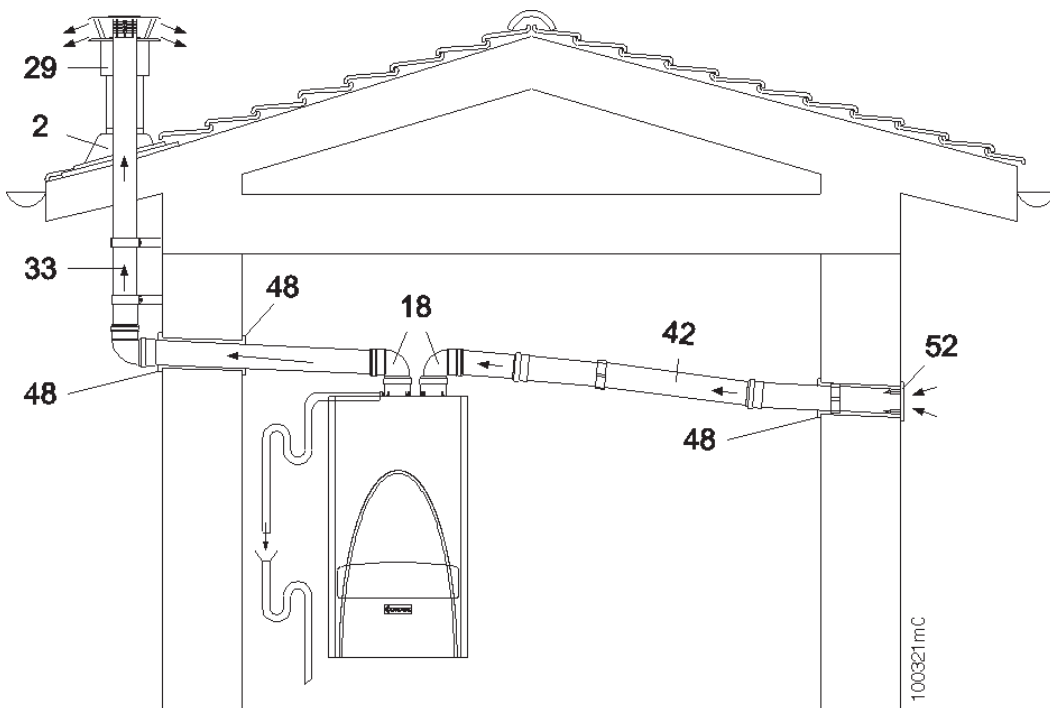
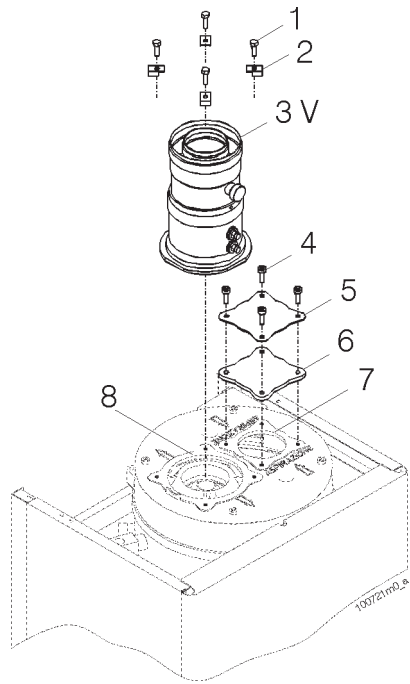

Figure 16 - Installation example

### 3 - INSTALLATION



**Figure 17 - Installation of the vertical coaxial system**

### 3.23.6 - 60/100 coaxial system

The heater does not come with fittings for the flue gas discharge / air intake connection. To connect the heater to a coaxial 60/100 system it is necessary to order the special kit for vertical flue gas discharge and install it as shown in figure 17 or the kit for horizontal flue gas discharge and install it as shown in the figure 18

To install the vent connection on top of the heater proceed as follows:

refer to figure 17 if you have a vertical flue gas discharge, or refer to figure 18 if you have a horizontal flue gas discharge;

- close the ventilation opening "7" with the seal "6", the flange "5" and the bolts "4";
- insert the "3V" (vertical discharge) or the "3O" (horizontal discharge) fitting in the opening "8" ;
- in the case of the "3O" fitting, it can be rotated in every direction in steps of 90°.

Fix the "3V" or "3O" fitting to the opening "8" using the brackets "2" and the bolts "1".

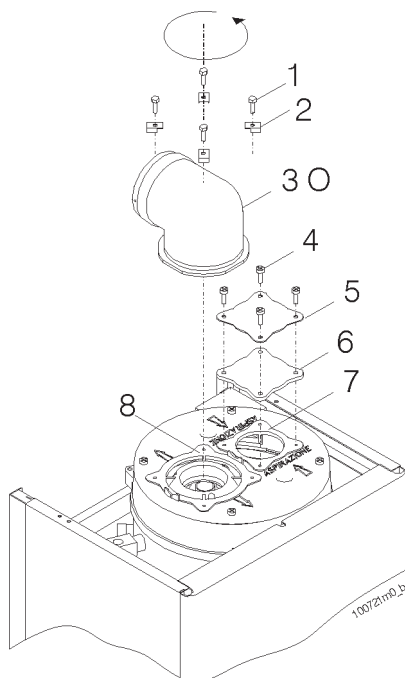

**Figure 18 - Installation of the horizontal coaxial system**

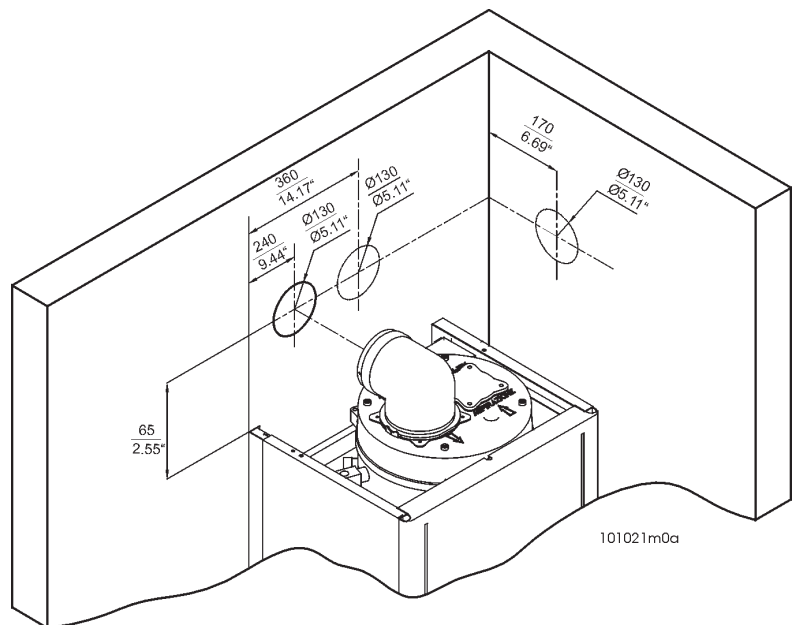

**Figure 19 - Positioning of the holes for horizontal coaxial flue gas discharge**

### 3 - INSTALLATION

**FIRST**, insert the vent inner pipe into the vent elbow and tighten using self-tapping screws “N”

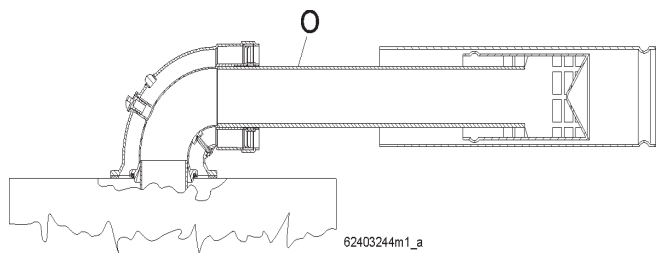

**SECOND**, fit the outer pipe and secure it with proper screws “P”

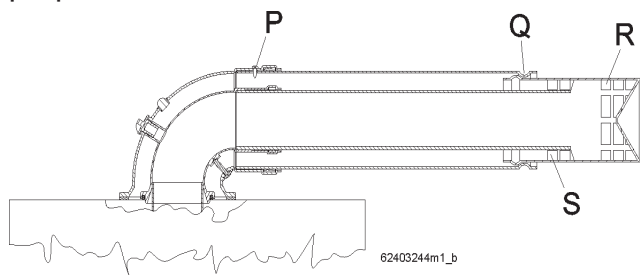

- N = Screws provided
- O = Inner pipe
- P = Screws provided
- Q = This position shall be respected
- R = Discharge grid
- S = Intake grid

**Figure 20 - Correct installation of the coaxial pipe**

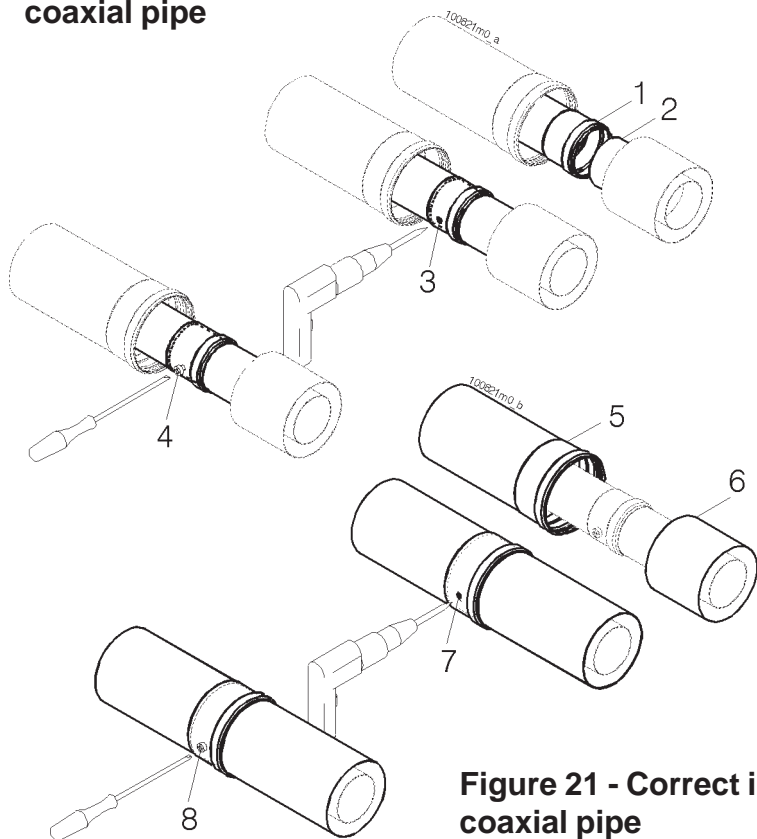

**Figure 21 - Correct installation of the coaxial pipe**



**CAUTION!!!** Be careful when

installing coaxial venting

Proper assembly and installation of venting elbows and tubing must include the use of self-tapping screws to permanently secure in place the internal and external discharge tube (see figure 20 item P and N). Self-tapping screws are used to insure that the discharge vent tube remains in place and not allow discharge gases to re-enter the heater. Failure to secure the internal discharge tube may result in the heater backfiring and causing permanent damage to the heat exchanger. Heaters which have been damaged for this reason are not covered in our limited warranty.

The stainless steel (End terminal) wind guard must fit properly and inter-lock into slip joint of intake pipe (see Figure 20 item Q).

It is imperative that the internal discharge pipe first be secured in place with self-tapping screws (see figure 20 item N) and before attaching and securing the external vent pipe (see figure 20 item P). Also, ensure that the two grids (R and S on the Figure 20) of the end terminal come completely out of the outer pipe. If the intake grid (see figure 20 item S) is hidden the heater will not receive enough air for combustion and would fail to ignite.

- Take particular care with the installation of the piping sections that pass through the wall toward the outside; these must always allow for normal maintenance actions, therefore install the pipes inside a liner to enable them to be pulled out
- Horizontal stretches should always have an inclination of at least 2% in the direction of condensation evacuation devices or toward the point of discharge into the atmosphere.
- The flue gas discharge / air intake system can be extended up to the maximum distance indicated in chapter 6 at the end of the manual. Every 90° bend has an equivalent loss to 3ft (1 m) of straight piping. Every 45° bend has an equivalent loss to 1.5ft (0.5 m) of straight piping.

### 3 - INSTALLATION

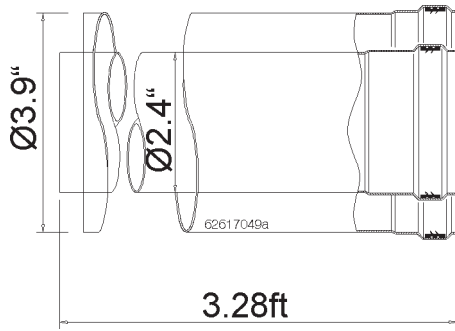

P/N 62617049

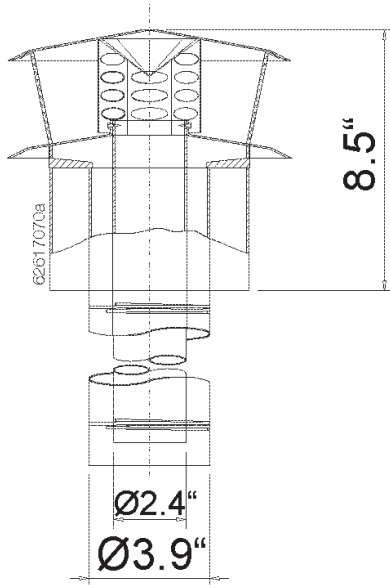

P/N 62617070

### 3.23.7 - 60/100 coaxial system: available accessories

For connecting the 60/100 coaxial discharge system, the following accessories are available on request: (the number after the P/N is used to refer to the part in the following drawings)

62617049 - N° 14, 3ft (1000 mm) extension

62617070 - N° 1, 3ft (1000 mm) roof terminal

62617087 - N° 5, 3ft (1000 mm) wall terminal

62617077 - N° 6, 90° M/F bend

62617159 - N° 15, 45° M/F bend

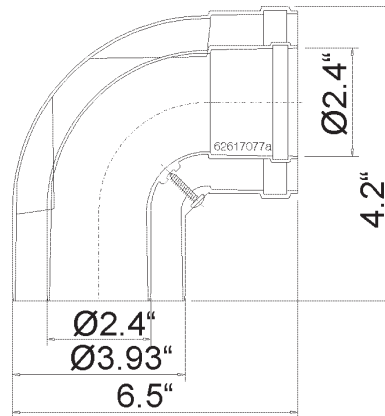

P/N 62617077

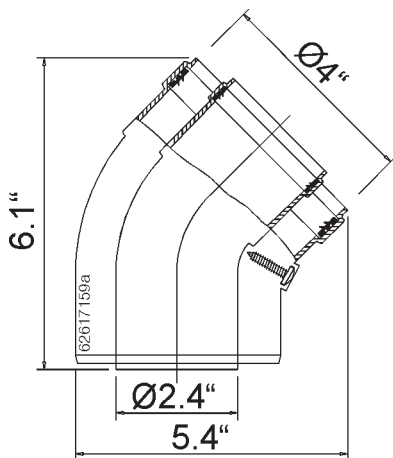

P/N 62617159

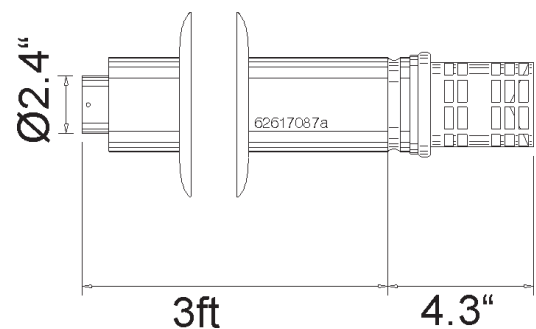

P/N 62617087

# 3 - INSTALLATION

## 3.23.8 - 60/100 coaxial system: installation examples

Figure 22 - Installation examples of the coaxial pipe

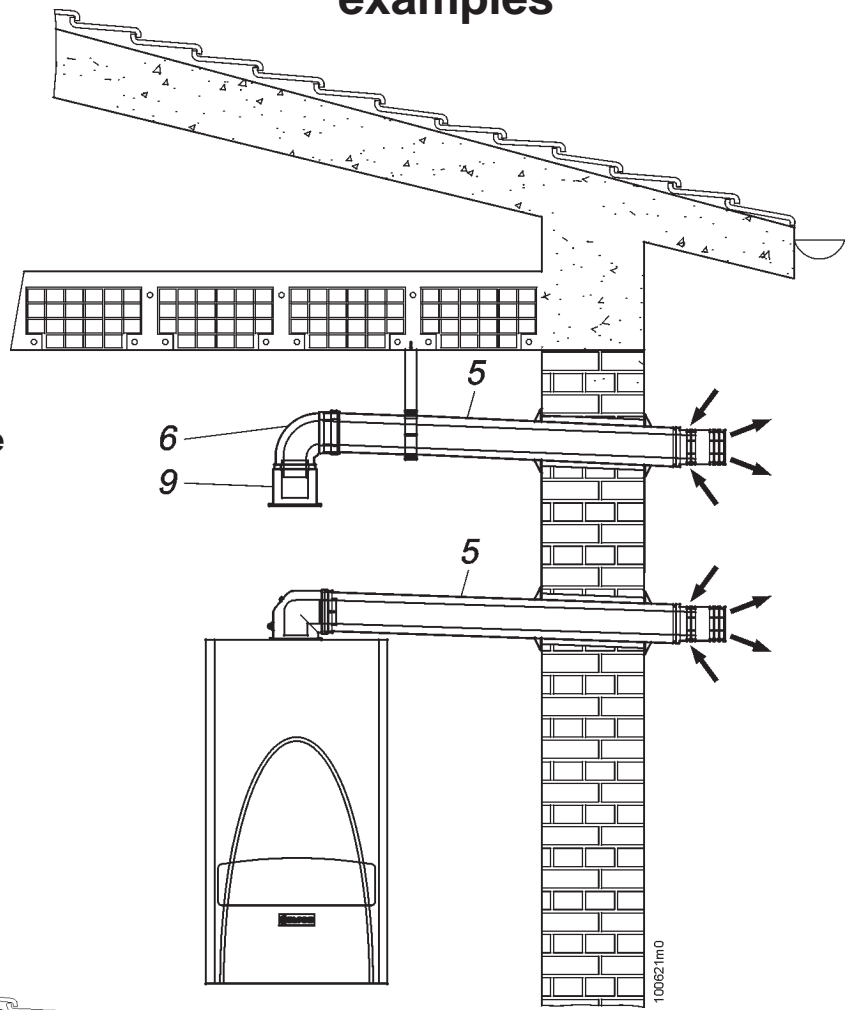

100621.m0

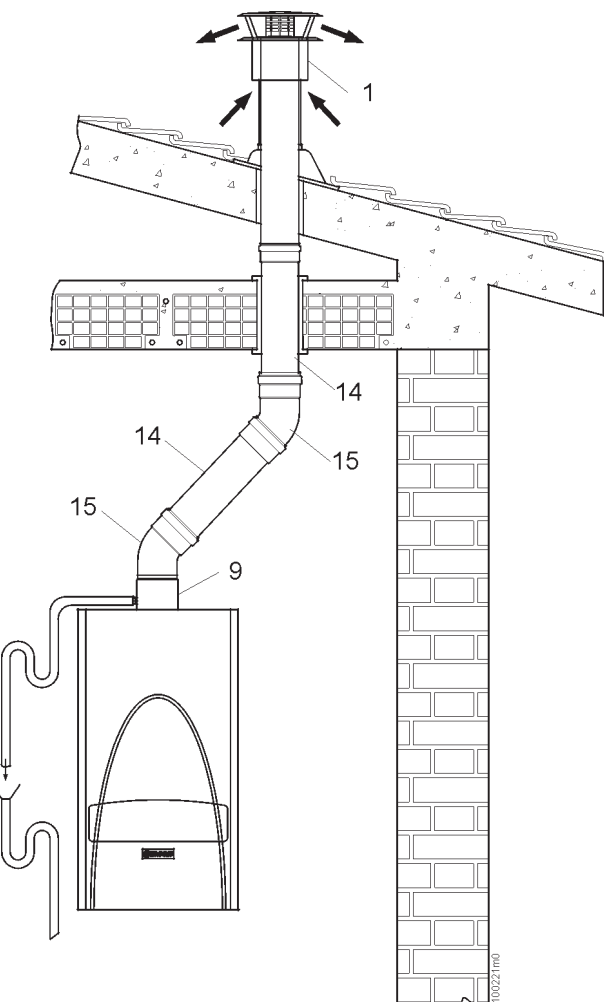

100621.m0

Figure 23 - Installation examples of the coaxial pipe

### 3 - INSTALLATION

#### 3.23.9 - Combustion air supplied from inside

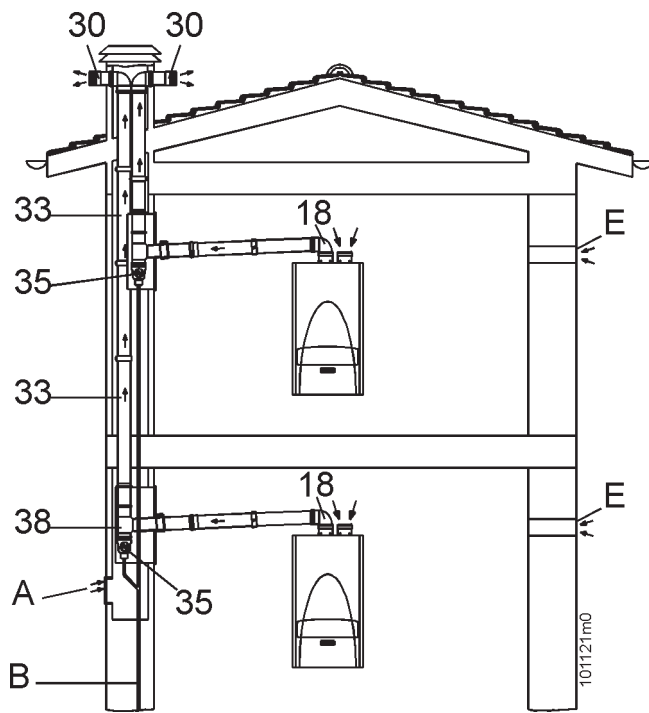

**Figure 24 - Installation examples of the air supplied from inside with a split system**

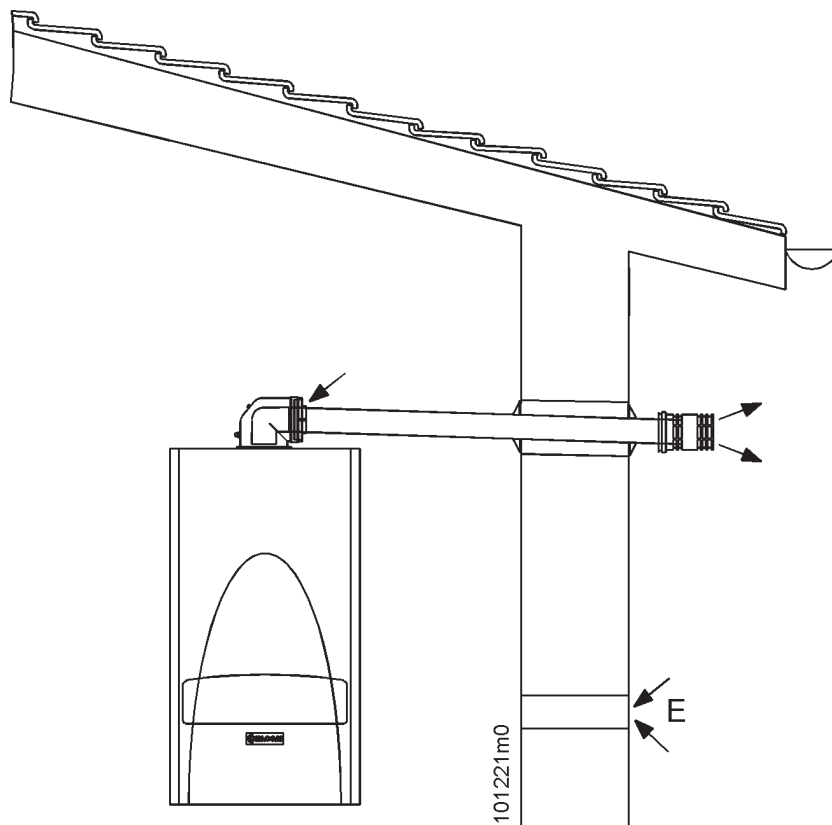

**Figure 25 - Installation examples of the air supplied from inside with a coaxial system**

If the heater is installed in a large open area such as a full basement or alcove, the combustion air can be supplied without the intake pipe, (See fig.24 and 25). The heater will draw all air for combustion through the top of the unit from the space around the heater. Ventilation should be adequate to provide sufficient air to properly support combustion. Air for combustion and room ventilation must be obtained from spaces freely communicating with the outdoors (see fig. 24 and 25 item E). Air openings to the room should not be obstructed. For heaters in confined rooms, two permanent openings must be provided - one within 12" (304 mm) of the ceiling and one within 12" (304 mm) of the floor. Each opening must be at least one square inch per 1,000 Btu/hr (0.29 kW) heater input, but not less than 100 square inches (645 cm<sup>2</sup>). These openings must freely connect with areas having adequate infiltration to the outside.

When all air provided is supplied from the outdoors, the openings, as described above, should be of the size listed below for each particular arrangement:

- All duct work shall be the same size as the opening to which it is to be connected.
- One square inch (6 cm<sup>2</sup>) of free area per 4,000 Btu/hr (1.17 kW) of heater input for direct outdoor air supply through an outside wall or vertical duct directly outside.
- One square inch (6 cm<sup>2</sup>) of free area for every 2,000 Btu/hr (0.59 kW) of heater input for direct outdoor air through horizontal ducting.

**CAUTION !!!** The discharge pipe temperature is above 250°F (121 °C) while functioning, therefore it is essential that a thermal insulation protection sheath be used in the wall opening.

### 3.23.10 - Removing the condensation produced by flue gas discharge

Due to the high efficiency of this heater, condensation will form in the discharge piping as a result of the cooling of the flue gases. It is therefore necessary to take every precaution to prevent this condensation from going inside the heater, by collecting it and removing it from the room.

The condensation must be emptied in such a way as to avoid the release of flue gases into drains or the environment. For this purpose, use appropriate traps such as the one illustrated in the figures 14, 15, 16, and 23 or similar.

In particular, the system for emptying condensation must:

- be connected to the domestic sewage system through an air trap to prevent the pressurisation of the system or the return of foul odours from the sewers;
- be executed using a tube having an internal diameter of at least 1/2" (13 mm);
- be installed so as to prevent the liquid from freezing; therefore take care with any outdoor sections; discharging into gutters or downpipes is forbidden;
- have a continuous downward incline toward the point of discharge; avoid high points which may put the piping under pressure.

Another technique used to remove the condensation is to simply incline the pipe toward the outside of the building, so that the condensation discharges outside (see fig. 14, 22, 25).

### 3 - INSTALLATION

### 3.24 - Water Connections

Each heater contains a kit of accessories to help the installer make the water connections. An example of these connections and all the accessories supplied with the heater is shown on the figure 26a:

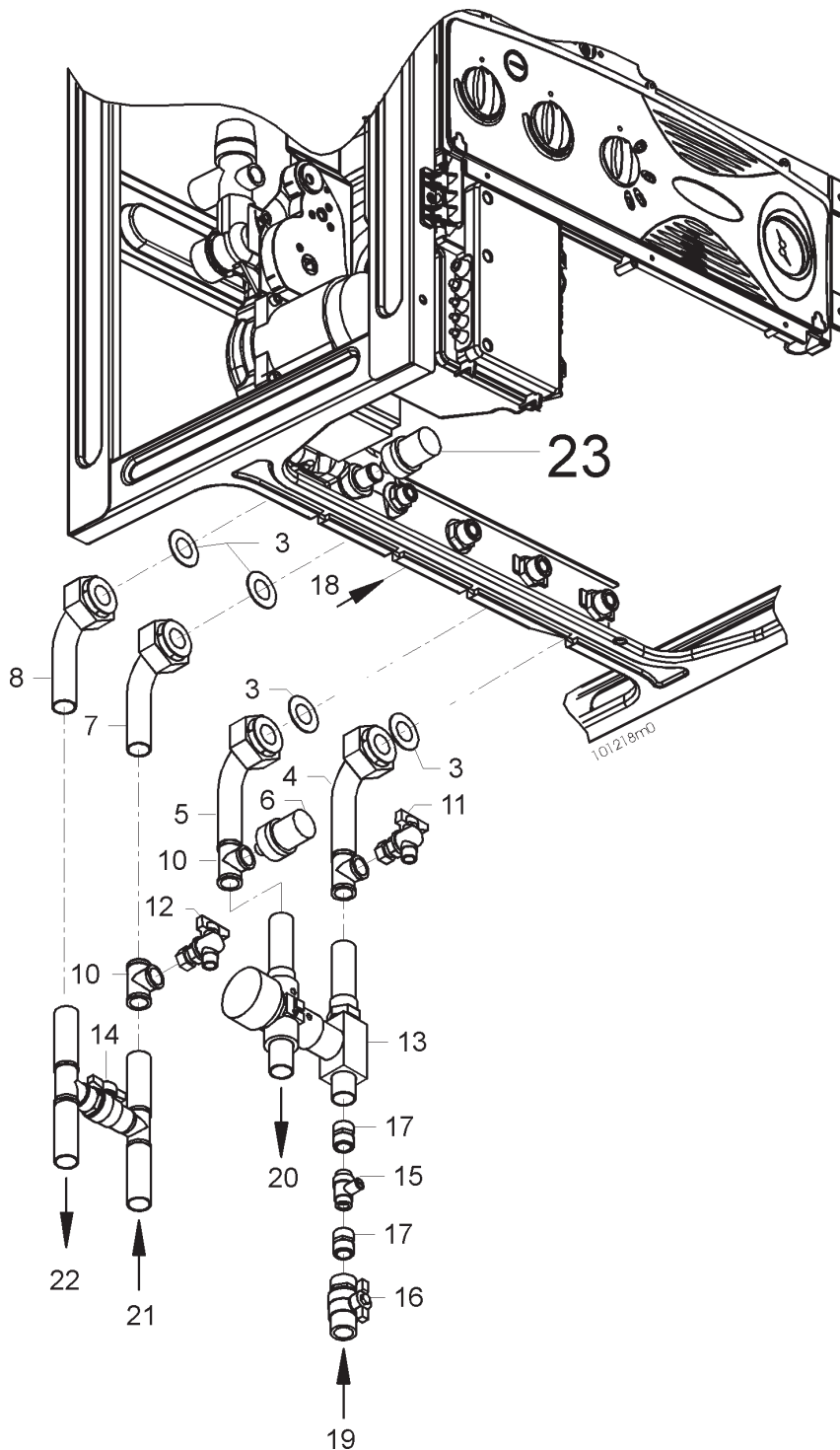

- 3) 1" Gasket
- 4) Domestic cold water connection
- 5) Domestic hot water connection
- 6) ASME Pressure relief valve 150 psi (not provided)
- 7) Heating return connection
- 8) Heating supply connection
- 9) ASME pressure relief valve 30 psi
- 10) Connections (not provided)
- 11) Domestic drain cock (not provided)
- 12) Heating drain cock (not provided)
- 13) Mixing valve (not provided)
- 14) By-pass valve (not provided)
- 15) Flow selector
- 16) Ball valve (not provided)
- 17) Fitting 1/2" NPT/Copper (not provided)
- 18) Gas supply (3/4")
- 19) Cold water inlet
- 20) Hot water outlet
- 21) Central heating return
- 22) Central heating supply
- 23) Low water cut-off

Figure 26 - Water connections

**CAUTION!!!**  
**COMPONENTS:**  
**6, 10, 11, 12, 13, 14, 16, 17**  
**ARE NOT PROVIDED!**

### 3 - INSTALLATION

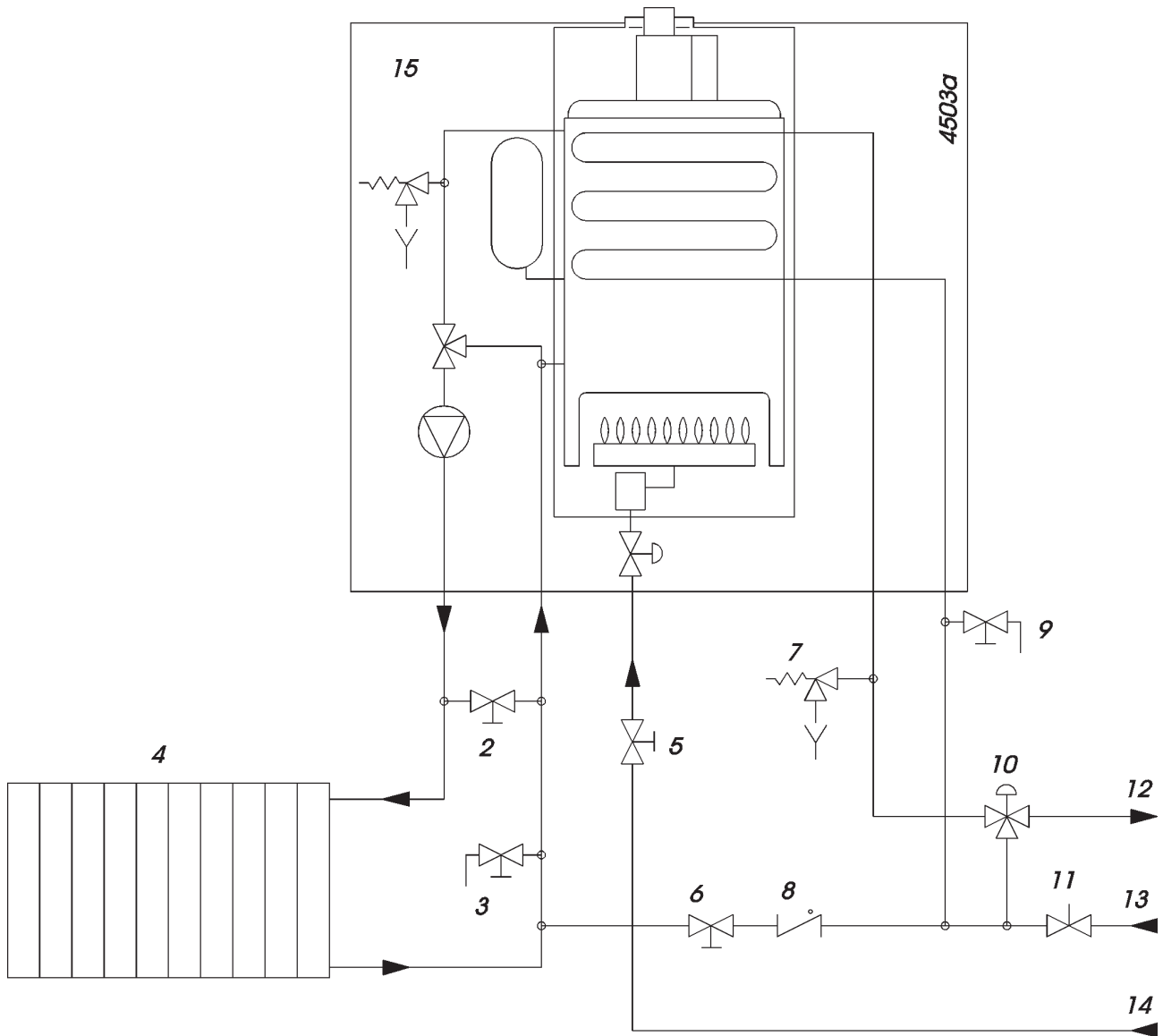

- |  |                       |
|--|-----------------------|
| 1 -                                      | 8 Back-flow preventer |
| 2 By-pass valve                          | 9 Sanitary drain cock |
| 3 Heating drain cock                     | 10 Mixing valve       |
| 4 Radiators                              | 11 Flow restrictor    |
| 5 Gas cock                               | 12 Hot water outlet   |
| 6 Automatic feed                         | 13 Cold water inlet   |
| 7 Safety Pressure relief valve (150 psi) | 14 Gas supply         |

Figure 27 - Hydraulic diagram of installation with radiators

### 3 - INSTALLATION

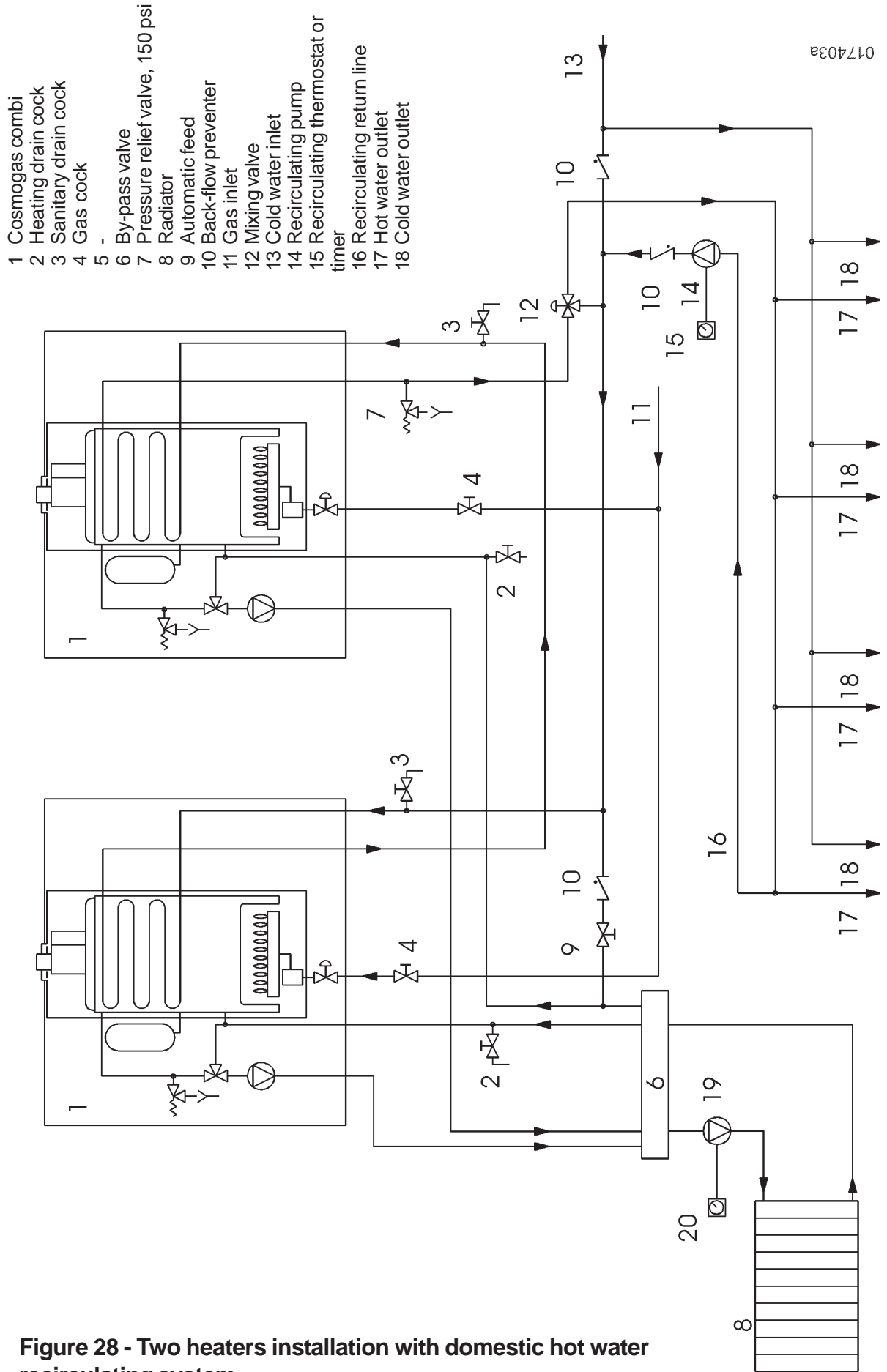

Figure 28 - Two heaters installation with domestic hot water recirculating system

# 3 - INSTALLATION

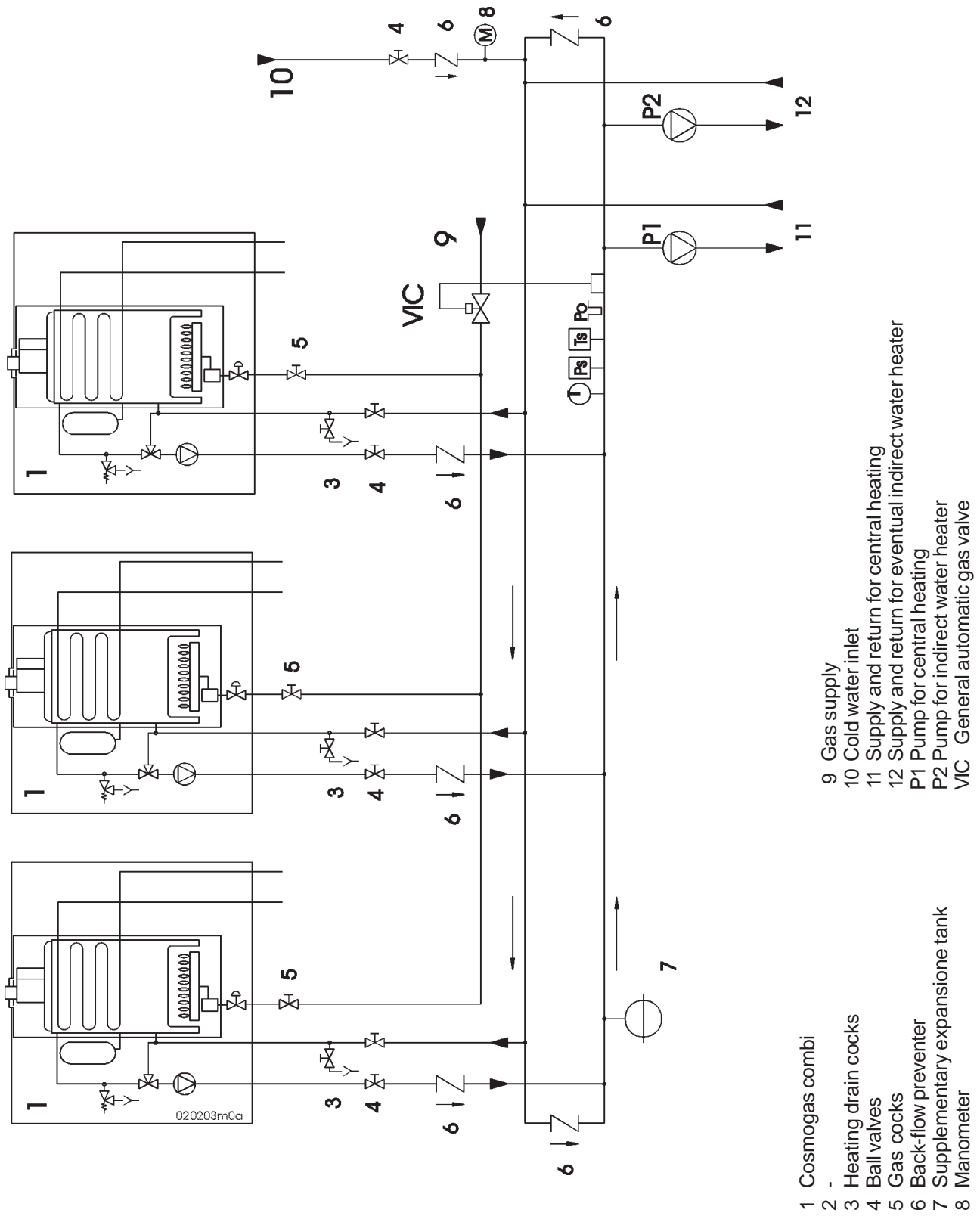
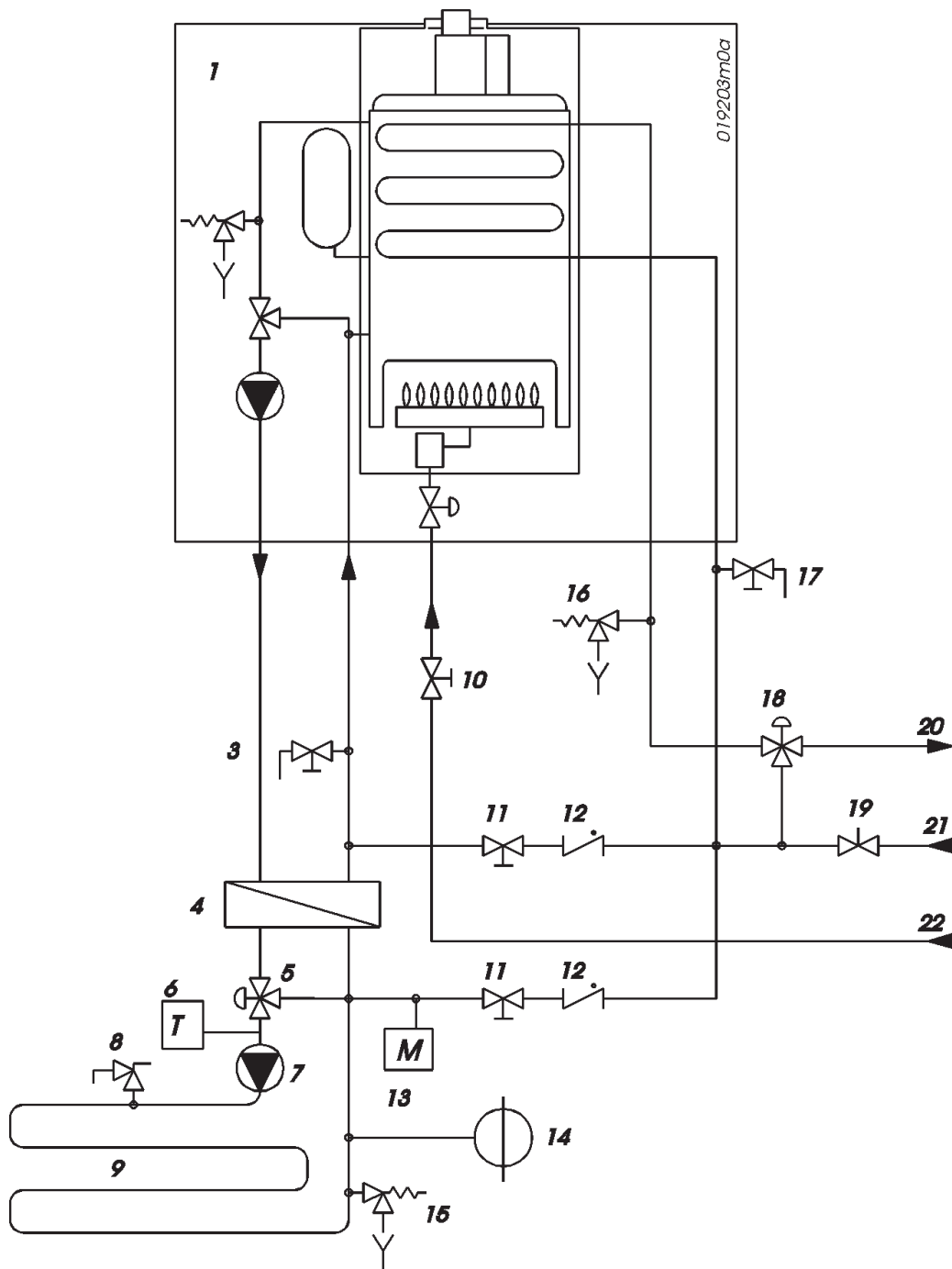

Figure 29 - Three or more heaters installation with connection for indirect water heater

### 3 - INSTALLATION



- |  |                                   |
|--|-----------------------------------|
| 1 Cosmogas combi                                     | 11 Automatic feed                 |
| 2 -  | 12 Back flow preventer            |
| 3 Heating Drain cock                                 | 13 Pressure gauge                 |
| 4 Plate heat exchanger                               | 14 Additional expansion tank      |
| 5 Three ways valve                                   | 15 Relief valve, 30 psi           |
| 6 Floor protection thermostat<br>set to 104°F (40°C) | 16 Pressure relief valve, 150 psi |
| 7 Supplementary pump                                 | 17 Sanitary drain cock            |
| 8 Air vent   | 18 Mixing valve                   |
| 9 Radiant heating                                    | 19 Flow restrictor                |
| 10 Gas cock  | 20 Hot water outlet               |
|  | 21 Cold water inlet               |
|  | 22 Gas inlet                      |

Figure 30 - Example of heater installation for radiant heating

### 3 - INSTALLATION

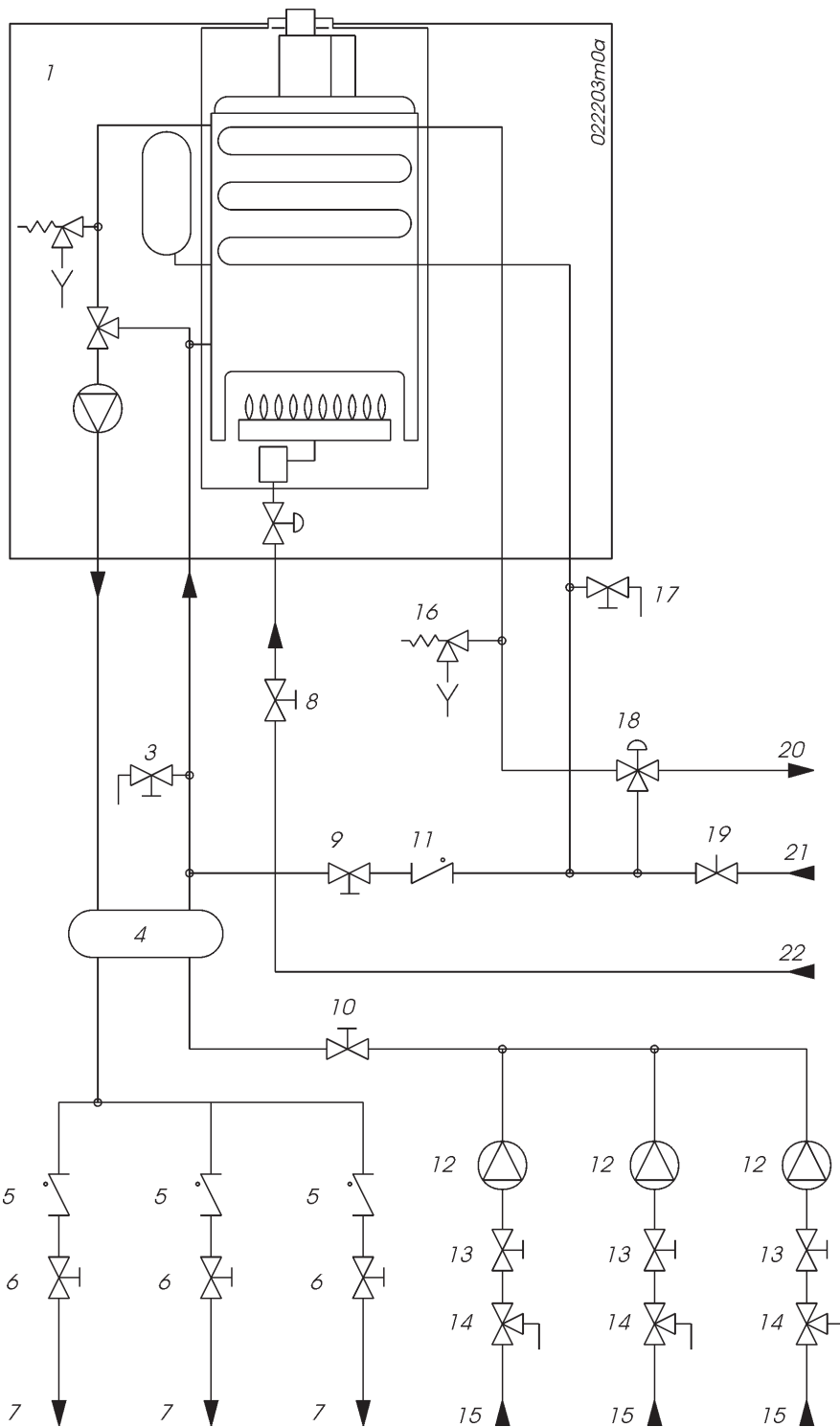

- |   |                                    |
|---|------------------------------------|
| 1 Cosmogas combi                        | 12 Added system pump               |
| 2 -                                     | 13 Optional ball valve             |
| 3 Heating drain cock                    | 14 Tees with drains to bleed zones |
| 4 Pressure disconnector                 | 15 Return piping from zones        |
| 5 Flow checks                           | 16 Pressure relief valve 150 psi   |
| 6 Optional ball valve to isolate heater | 17 Sanitary drain cock             |
| 7 Supply piping to zones                | 18 Mixing valve                    |
| 8 Gas cock                              | 19 Flow restrictor                 |
| 9 Automatic feed                        | 20 Hot water outlet                |
| 10 Optional ball valve                  | 21 Cold water inlet                |
| 11 Back-flow preventer                  | 22 Gas inlet                       |

**Figure 31 - Zoning with pumps - Multizone hydronic piping**

# 3 - INSTALLATION

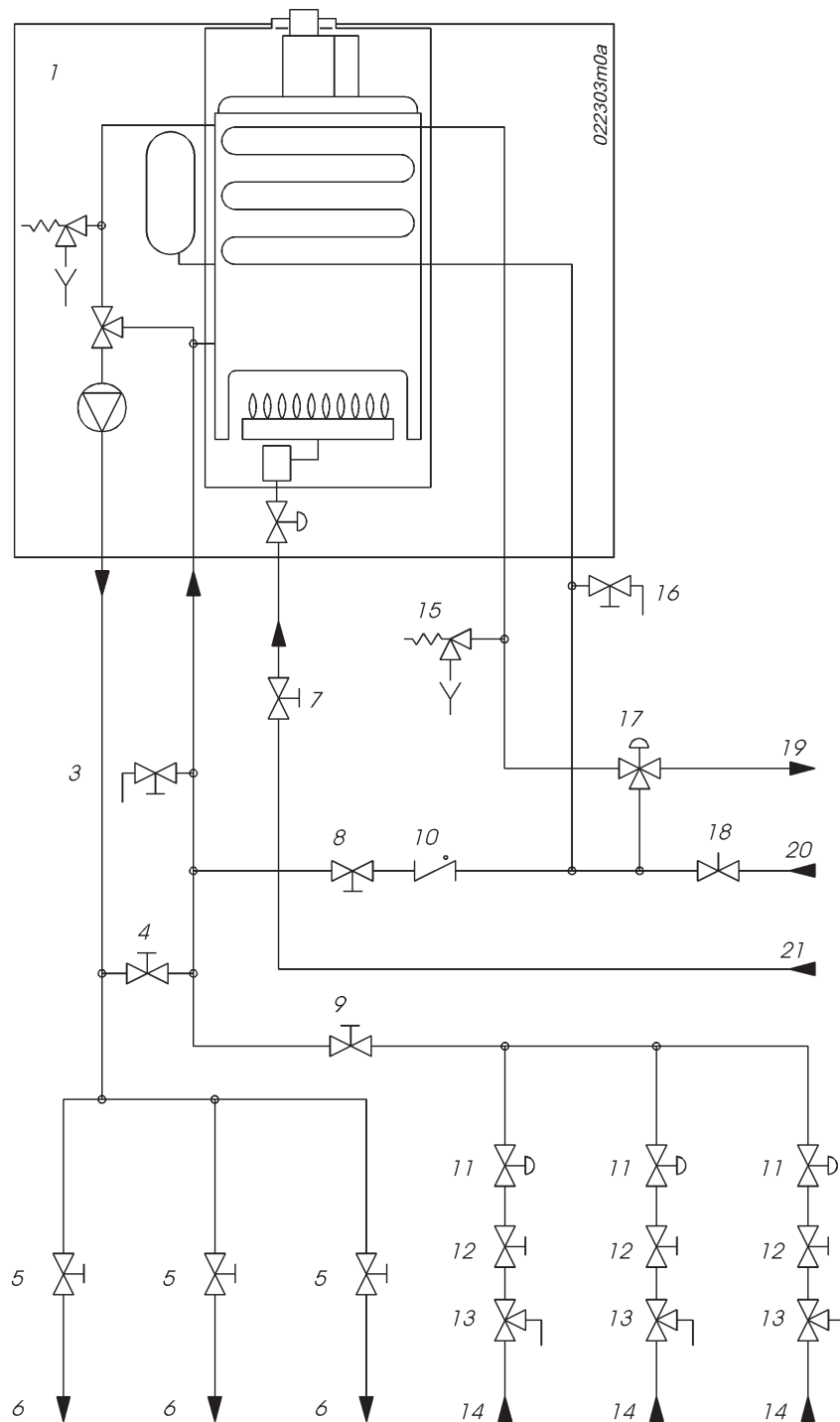

- |   |                                    |
|---|------------------------------------|
| 1 Cosmogas combi                        | 11 Zone valves                     |
| 2 -                                     | 12 Optional ball valve             |
| 3 Heating drain cock                    | 13 Tees with drains to bleed zones |
| 4 By-pass valve                         | 14 Return piping from zones        |
| 5 Optional ball valve to isolate heater | 15 Pressure relief valve, 150 psi  |
| 6 Supply piping to zones                | 16 Sanitary drain cock             |
| 7 Gas cock                              | 17 Mixing valve                    |
| 8 Automatic feed                        | 18 Flow restrictor                 |
| 9 Ball valve                            | 19 Hot water outlet                |
| 10 Back-flow preventer                  | 20 Cold water inlet                |
|   | 21 Gas inlet                       |

Figure 32 - Zoning with zone valves - Multizone hydronic piping.

# 3 - INSTALLATION

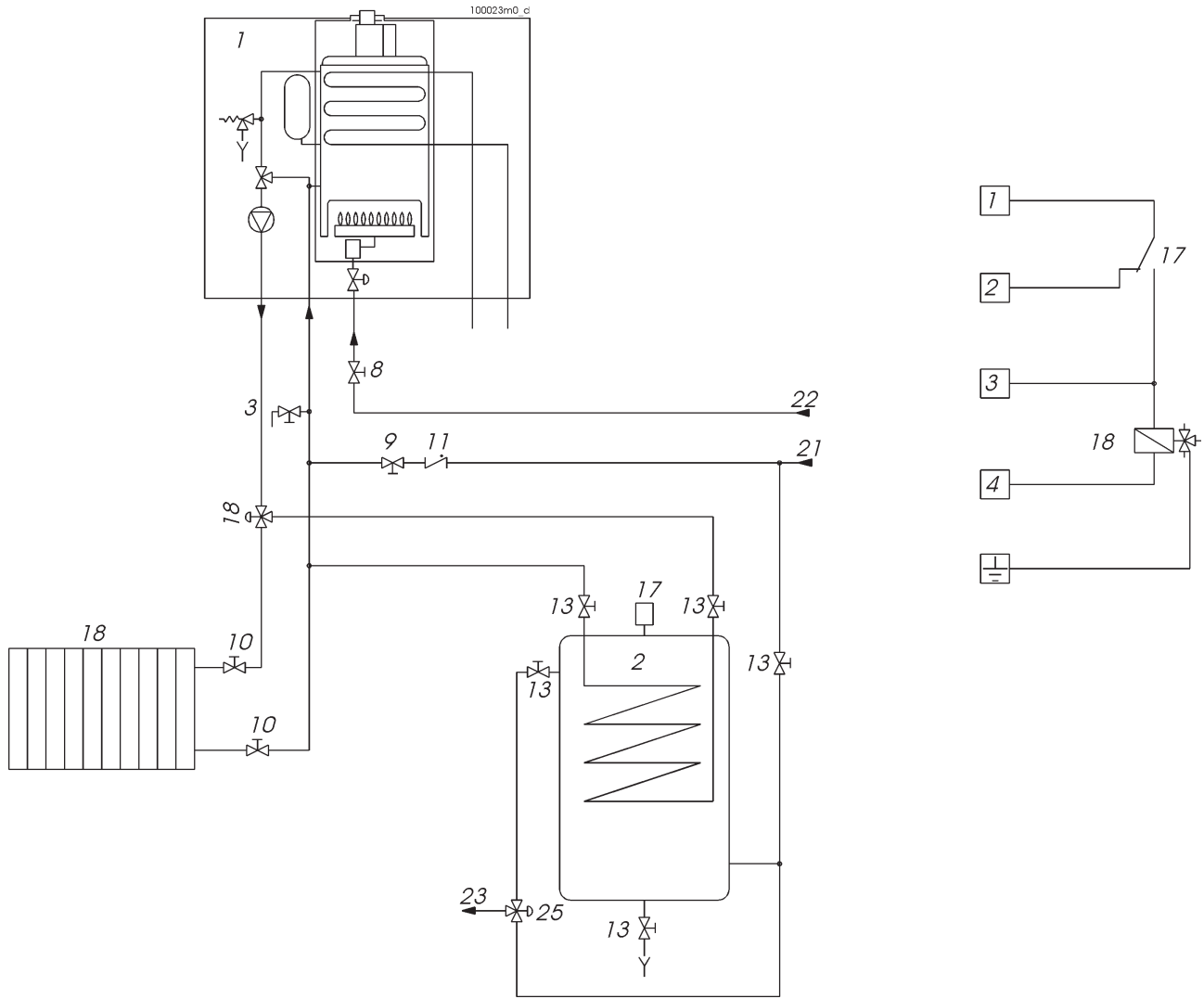

- |  |   |   |
|--|---|---|
| <p>1</p> <p>2</p> <p>3</p> <p>4</p> <p>com</p> <p>GROUND</p> | <p>1 Cosmogas combi</p> <p>2 Indirect water heater</p> <p>3 Heating drain cock</p> <p>4 -</p> <p>5 Back-flow preventer</p> <p>6 Ball valve to isolate the heater</p> <p>7 Supply piping to zones</p> <p>8 Gas cock</p> <p>9 Feeding cock</p> <p>10 Ball valve</p> | <p>11 Back-flow preventer</p> <p>12 Circulating pumps</p> <p>13 Ball valve to isolate zones</p> <p>14 Tees with drains to bleed zones</p> <p>15 Return piping from zones</p> <p>16</p> <p>17 I.W.H Aquastat or plate heat exchanger aquastat</p> <p>18 Electrical three ways valve</p> <p>19 Plate heat exchanger</p> <p>20 Hot water outlet</p> <p>21 Cold water inlet</p> <p>22 Gas inlet</p> <p>23 Hot water outlet from I.W.H.</p> <p>24 Radiators</p> <p>25 Mixing valve</p> <p>R Relays</p> |
|--|---|---|

This legend is valid also for the next three drawings

Figure 33 - Indirect Water Heater installation

# 3 - INSTALLATION

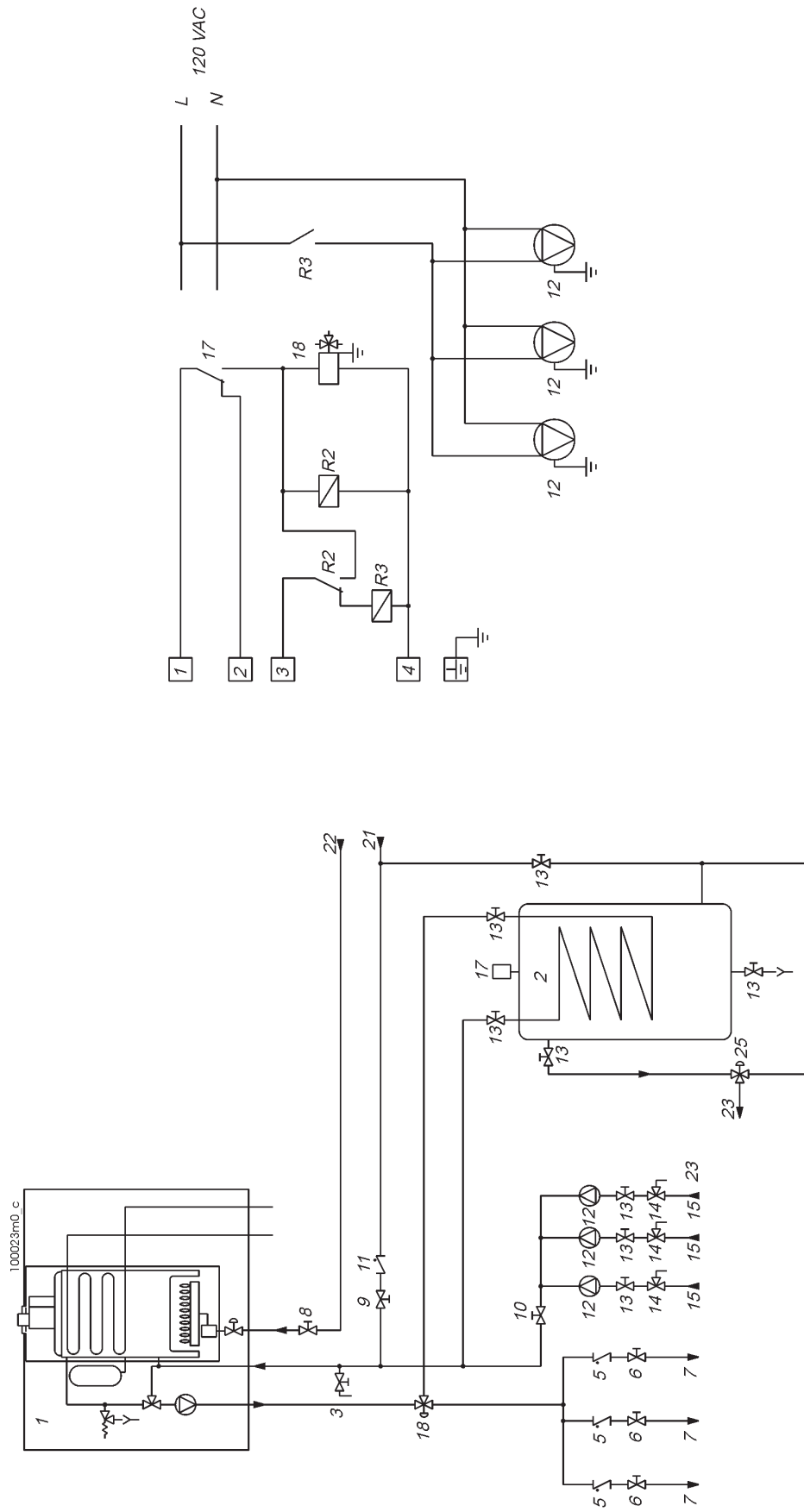

Figure 34 - Indirect Water Heater and more pumps installation

# 3 - INSTALLATION

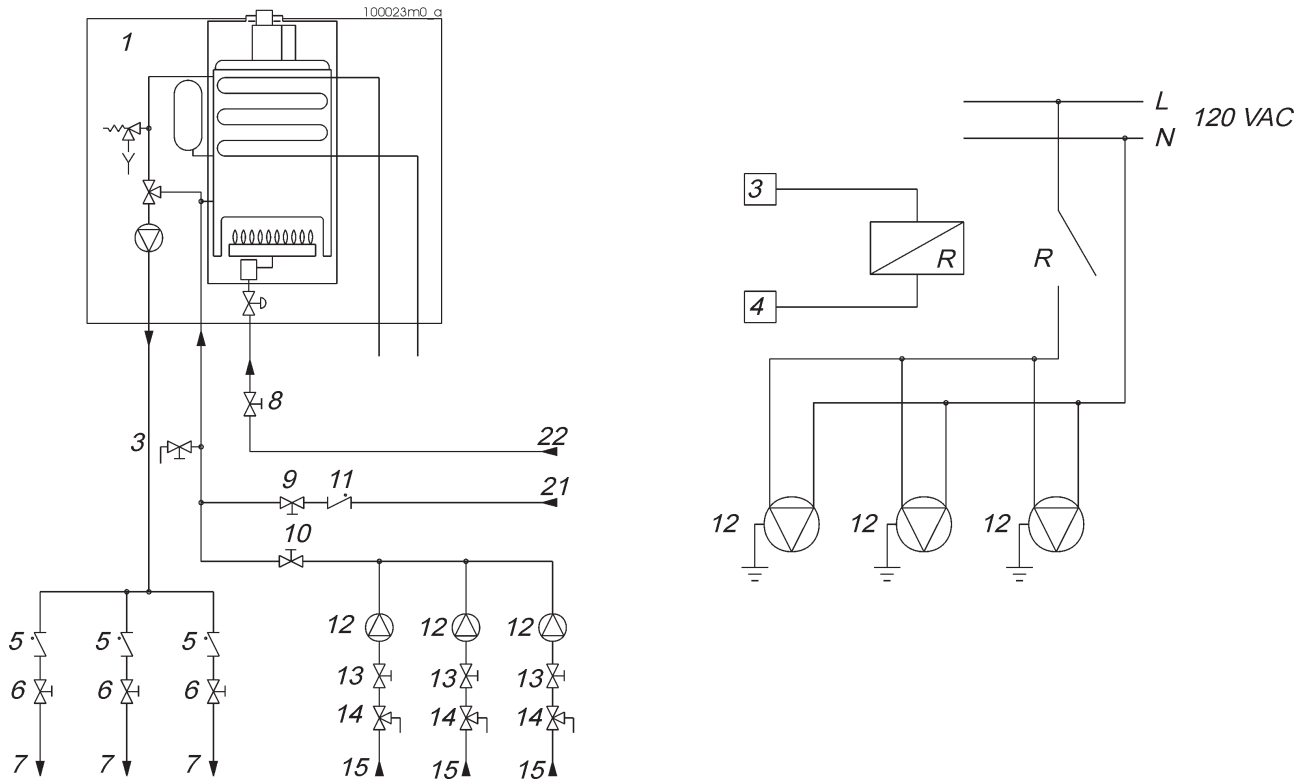

Figure 35 - More pumps installation

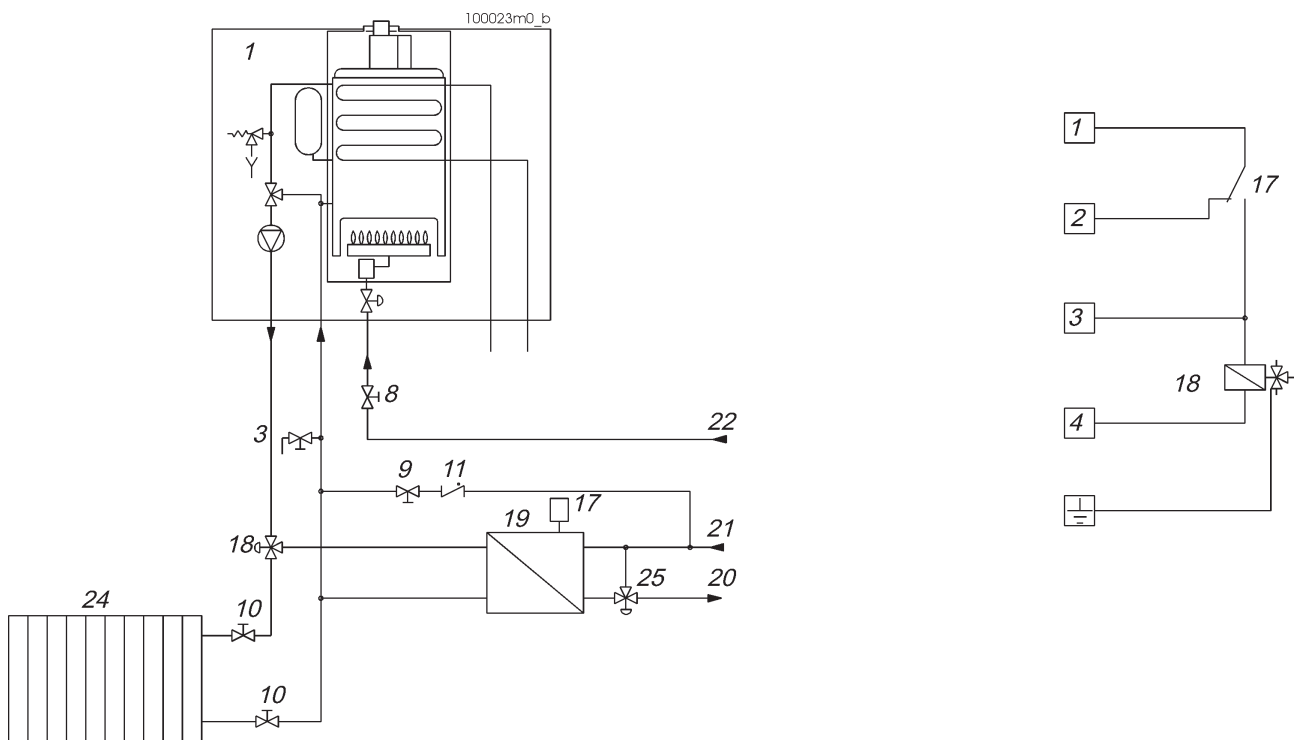

Figure 36 - Plate heat exchanger installation

# 3 - INSTALLATION

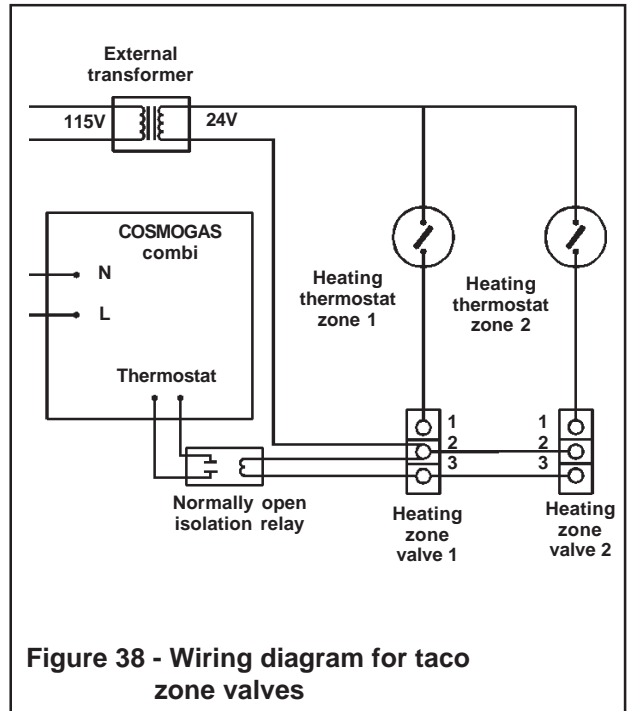
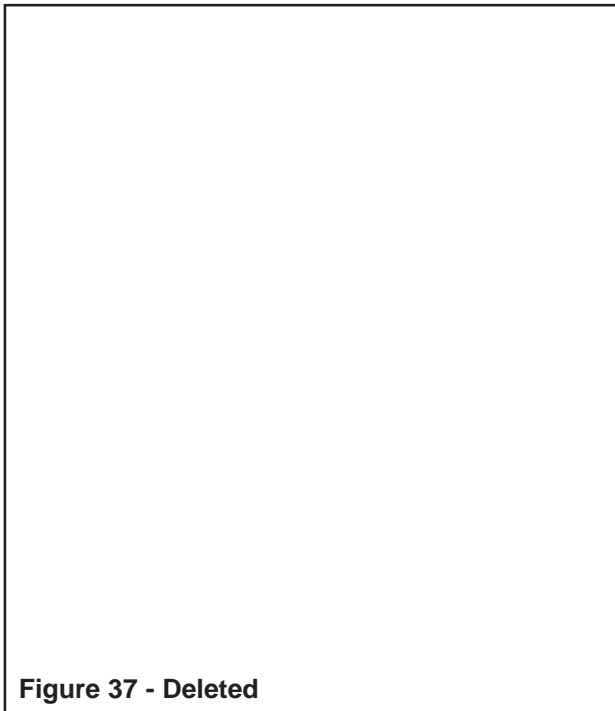

Figure 38 - Wiring diagram for Taco zone valves

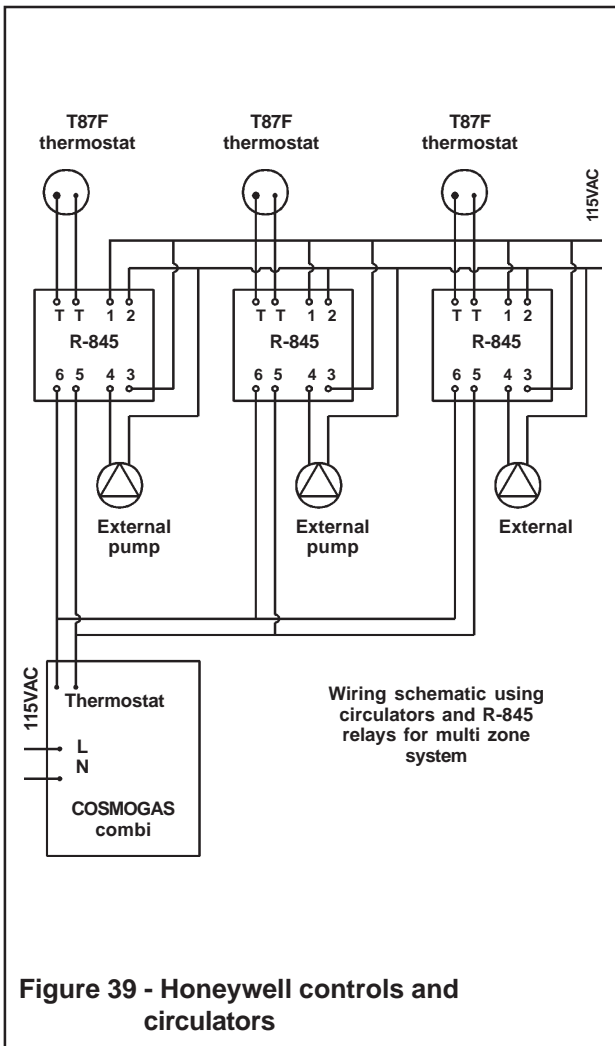

Figure 39 - Honeywell controls and circulators

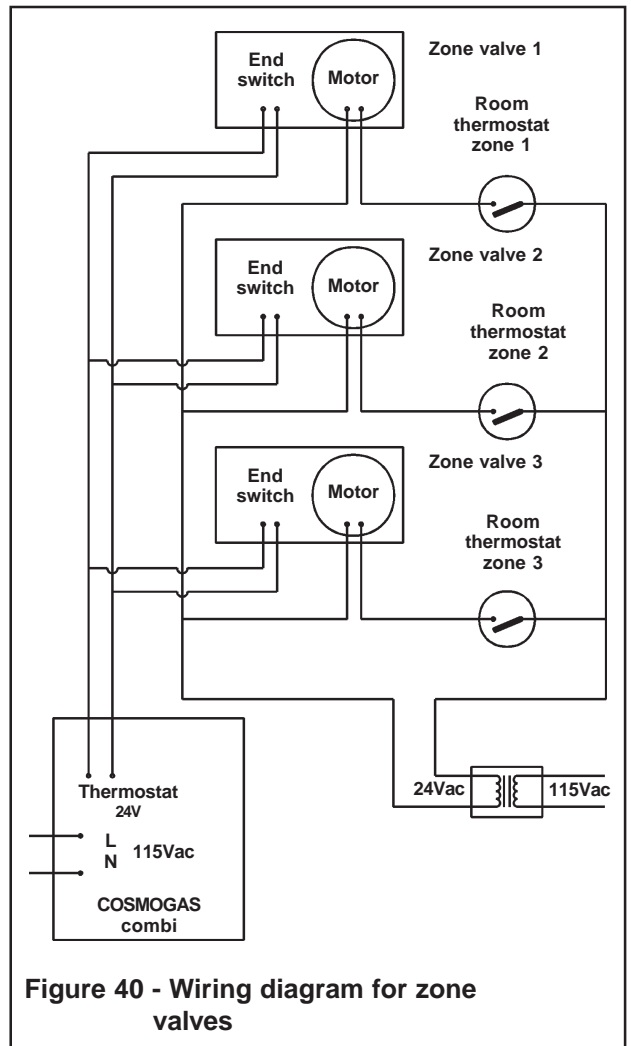

Figure 40 - Wiring diagram for zone valves

## 3 - INSTALLATION

### 3.25 - Filling the heating system

Fill the heating system using only cold water from the main water supply; proceed as follows:

Check that the system has been filled and purged.

The indicator on the pressure gauge "6" (see fig.48), should read between 15 and 25 psi (1 and 1.7 bar).

If the pressure gauge reads below 15 psi (1 bar), open the automatic feed using the fast fill feature and allow the system to fill, until the pressure gauge reads 25 psi (1.7 bar)

To properly purge the heating system of air it is imperative that these basic instructions be followed.

The automatic feed should have a fast fill feature. There must be an isolation valve installed so that when it is closed it will direct the incoming water flow through the system and heater in the normal flow pattern and out a drain cock installed at the end of the loop.

- a) Attach a hose to the heating drain cock and run the hose to a suitable drain.
- b) Open heating drain cock.
- c) Open the automatic feed using the fast fill feature and allow the system to fill purge. On multi-zone systems, each zone must be purged separately with the other zones shut off.

unscrew the air vent cap located in top of heater (see figure 1 item 3).

### 3.26 - Ignition

Open the gas cock.

Switch on the electrical on/off switch to the heater.

Rotate selector "4" (see fig. 48) to position "C" (Domestic hot water plus heating).

The circulation pump starts only when the heater temperature exceeds 140°F (60°C) and when the room thermostat calls for heating.

If the pump indicator "C" (see fig.

45) is illuminated but the pump is not running, this might indicate that the pump is frozen in place, remove the screw cap on the pump and rotate with a screwdriver to try releasing it.

If the pump indicator is illuminated but the radiators fail to heat up adequately, this might be an indication that there is air in the system. Re-purge the system until air is eliminated.

### 3.27 - Regulating the domestic hot water

The heater temperature control knob is adjusted to its lowest temperature position when shipped from the factory. Prior to starting the heater, it should be adjusted to a minimum starting point of 140°F (60°C) as shown on the heater's temperature control. After installing the heater, it is necessary to regulate the flow rate of the domestic hot water so as to give a 75°F (42°C) rise. For this function, you need to use a flow meter and a thermometer. Place the flow meter, under a hot water faucet, closest to the heater and open the faucet until water temperature is stabilized. The difference between cold and hot water should be approximately 75°F (42°C). Increase or decrease the water flow by regulating the incoming cold water to the heater with the DHW flow restrictor (see figure 23, items 15).

When water temperature requirements for heating are higher than the temperature of the domestic hot water, (120° F (49°C)) you must temper the domestic hot water output to reduce the potential hazard of scalding. **It is IMPARATIVE that a mixing valve be installed external of the heater to further regulate the temerature of the domestic hot water.**

### 3 - INSTALLATION

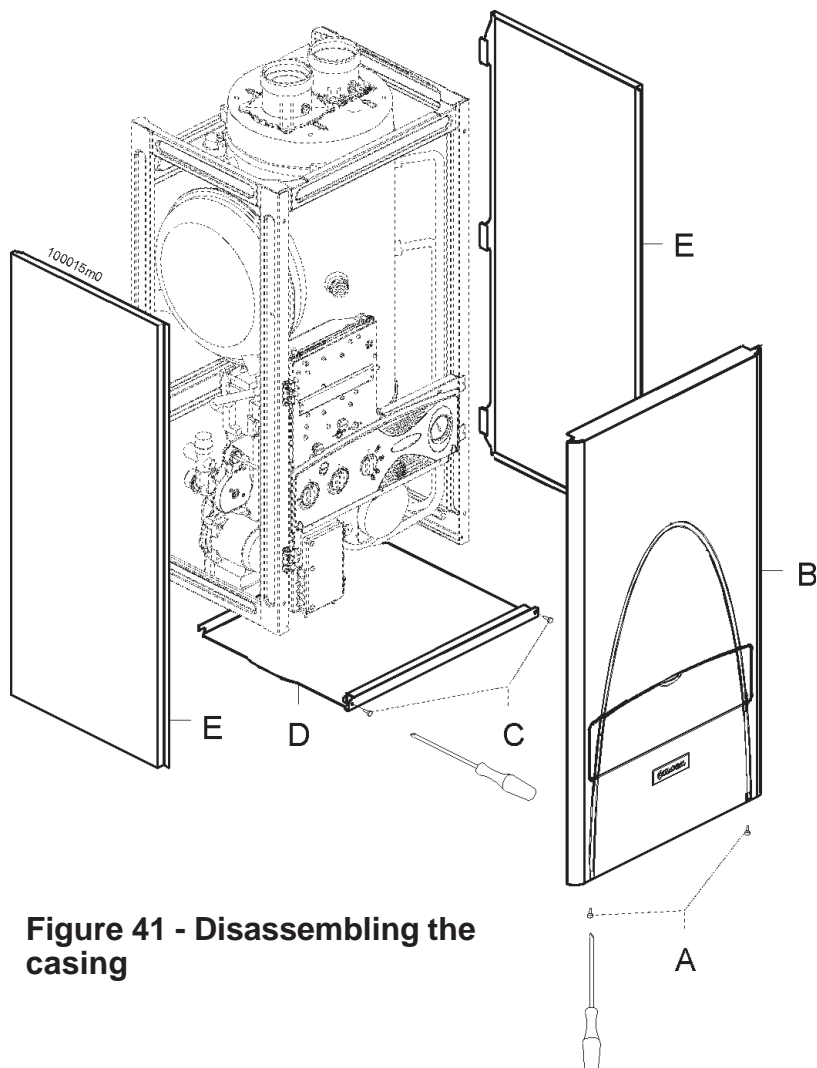

**Figure 41 - Disassembling the casing**

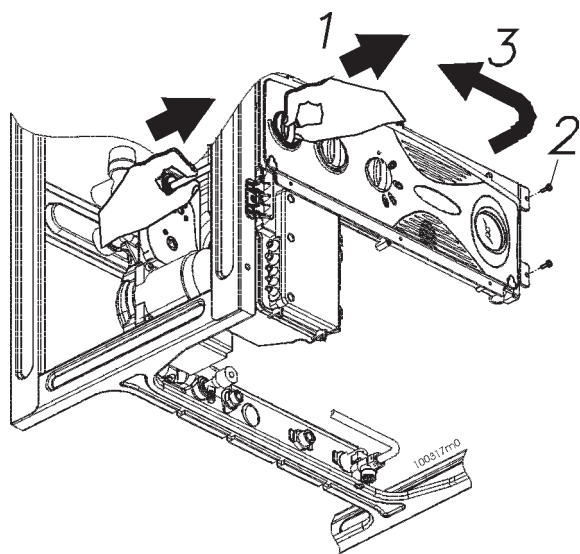

**Figure 42 - Instrument panel opening**

### 3.28 - Disassembling the cover panels

To disassemble the cover panels, proceed as follows (refer to figure 41):

- unscrew the two “A” screws from the bottom of the front panel;
- pull the bottom of the front panel “B” out about 2 in. (5 cm);
- lift the front panel “B” out to release;
- release side panels “E” by swinging out front portion approximately 2 in. (5 cm);
- unscrew the “C” screws from the bottom panel and pull down panel section “D”.

### 3.29 - Accessing the internal components

To access the internal components of the heater: gas valve, blower, pump, etc., proceed as described below, (refer to figure 42):

- unsew two screws labeled “2”;
- swing open the instrument panel in the direction of arrow “3”.

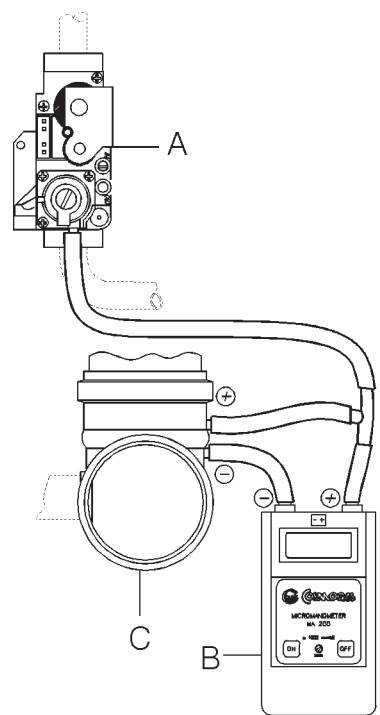

**Figure 43 - Checking the gas pressure at the burner**

## 3 - INSTALLATION

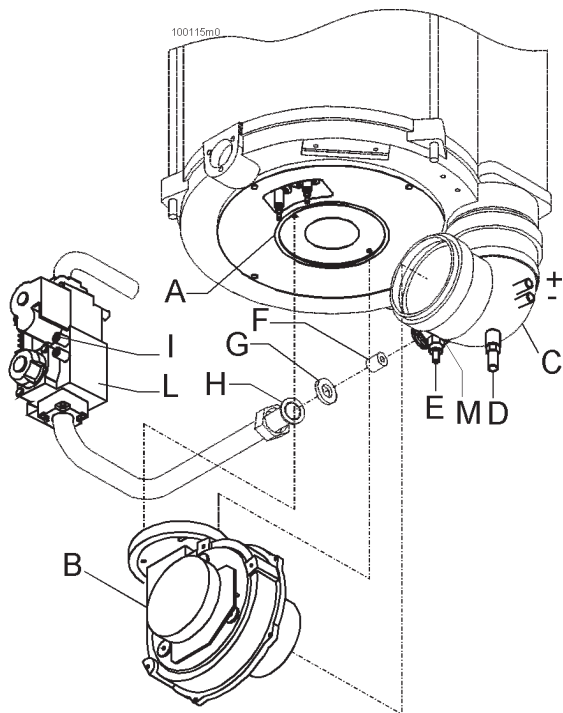

- A - Burner
- B - Blower
- C - Fitting for blower
- D -
- E -
- F - Gas injector
- G - Gasket
- H - Gas pipe
- I - Inlet gas pressure probe
- L - Gas valve
- + and - = burner pressure probes

**Figure 44 - Premixing components**

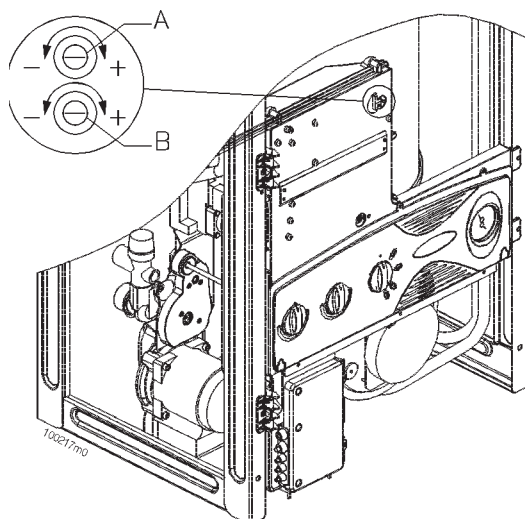

- A - Maximum power regulator
- B - Minimum power regulator

**Figure 45 - Maximum and minimum power regulators**

### 3.30 - Converting the burner to use a different type of gas

The conversion of the burner to use a different type of gas must be carried out by a qualified technician.



**CAUTION!!!** If the available

gas supply does not match the type of gas with which the heater can function, it is necessary to convert the appliance.

To convert the heater from one gas type to another (NAT to LP or LP to NAT). The conversion kit is supplied together with the water heater.

### 3.31 - Checking and adjusting the pressure of the gas supply

The pressure of the gas supply must match the values given in the table in chapter 8 at the end of the manual. To check the pressure, proceed as follows:

- close the gas cock;
- remove the heater cover panels
- unscrew the pressure probe "I" (see figure 44);
- connect a pressure gauge with a resolution of at least 0.05 In.W.C. (0.1 mbar);
- open the gas cock;
- switch on the heater and compare the pressure reading with the value given in table 8.1 (Section 8- Technical Data)
- close the pressure probe
- perform a leakage test

If the pressure does not fall within the maximum and minimum range given in table 8.1, it is necessary to operate upstream of the heater to bring the pressure within the prescribed range.



**CAUTION!!!** Also check

the supply pressure when the burner is off. In this condition the pressure must not, in any circumstances, exceed the maximum pressure given in table 8.1.

### 3.32 - Checking and adjusting the gas pressure at the burner

The gas pressure of the burner must match the values given in the table in chapter 8. The heater operates between two power levels, and therefore there are 2 values of burner pressure that must be checked, one for the maximum input rate and one for the minimum input rate.

To check the pressure proceed as follows:

- remove the heater cover panels
- remove the screw from the pressure probe “-” (minus) on elbow “C”, see figure 44;
- remove the silicone tube from the pressure coupling “+” (plus) on elbow “C”, see figure 44;
- connect a pressure gauge with a resolution of at least 0.05 in.W.C. (0.1 mbar), making a T connection as shown in figure 43;
- be sure to maintain the correct polarities between the connections;
- turn on the heater, keeping selector “4” in position “C” (see figure 48) and compare the measured value with that given in table 8.1 under the heading “(Natural or LP) gas maximum burner pressure”;
- with the heater at a temperature higher than 140°F (60°C), rotate selector “4” to position “D” (see figure 48) and compare the measured value with that given in table 8.1 under the heading “(Natural or LP) gas minimum burner pressure”.

If the above values do not match those given in table 8.1, it is necessary to operate as follows to adjust the pressure.

- use regulator “A” (see figure 45) to adjust the maximum pressure with selector “4” in position “C” (see figure 48);
- use regulator “B” (see figure 45) to adjust the minimum pressure; Be sure that the heater is at a temperature higher than 140°F (60°C), selector “4” is in position “D” and that “C” lamp is lit (see figure 48)

After making any adjustments, reassemble the unit, being careful to seal the regulators “A” and “B” (see figure 45) with a drop of red paint or similar method.

### 3.33 - Check CO2 level

During normal operation at altitudes below 2000 ft (659 m), the CO<sub>2</sub> (carbon dioxide) content of the heater flue gases is given in table 8.1 at the end of the manual. A different value from that shown may result in a malfunction. To check this value it is necessary to analyze the exhaust fumes using a combustion analyzer; proceed as follows:

- connect a combustion analyzer to the special coupling on the flue gas discharge fitting;
- rotate selector “4” (see figure 48) to the “B” position (sanitary hot water);
- open the hot water valve until the temperature inside the water heater reaches and maintains temperature at approximately 160±10°F (70±5°C)
- compare the measured value with that shown in chapter 8 “CO<sub>2</sub> content”

## 3 - INSTALLATION

---

### 3.34 - Adjusting the input rating to the required heat loss

The input rating of the heater can be varied anywhere between the minimum and maximum setting of the heater to meet the required heat loss of the space being heated.

To adjust the input rating see diagram in paragraph 8.3 showing the correlation between the input rating with the gas pressure to the burner.

This diagram can be applied to both NATURAL gas and LP gas.

To proceed follow these instructions:

- remove the heater cover panels;
- remove the screw from the pressure probe “-” (minus) on elbow “C”, see figure 44;
- remove the silicone tube from the pressure coupling “+” (plus) on elbow “C”, see figure 44;
- connect a pressure gauge with a resolution of at least 0.05 in.W.C. (0.1 mbar), making a T connection as shown in figure 43;
- be sure to maintain the correct polarities between the connections;
- turn on the heater, keeping selector “4” in position “D” (see figure 48). Heating energy saving position;
- After the heater reaches a temperature above 140°F (60°C), light “C” (see figure 48) should be lit;

In this state you can adjust the input rating in the follow manner:

- verify the required heat loss
- compare the diagram in chapter 8.3 to the correct burner pressure for your required heat.
- use regulator “B” (see figure 45) to adjust the minimum burner gas pressure to the correct input rating for your heat loss. Be sure when you make this adjustment that lamp “C” is lit.

NOTE: Your domestic hot water output will always function at the maximum input rating.

### 3.35 - Adjust the input rating to the required maximum efficiency

The input rating of the heater can be varied anywhere between the minimum and maximum setting of the heater to meet the required heat loss of the space being heated.

The efficiency of the heater changes in relation to the adjusted input rating. The diagram in paragraph 8.4 shows the correlation between the input rating and the efficiency.

When adjusting your input rating follow paragraph 3.34, taking into consideration this parameter.

## 4 - MAINTENANCE

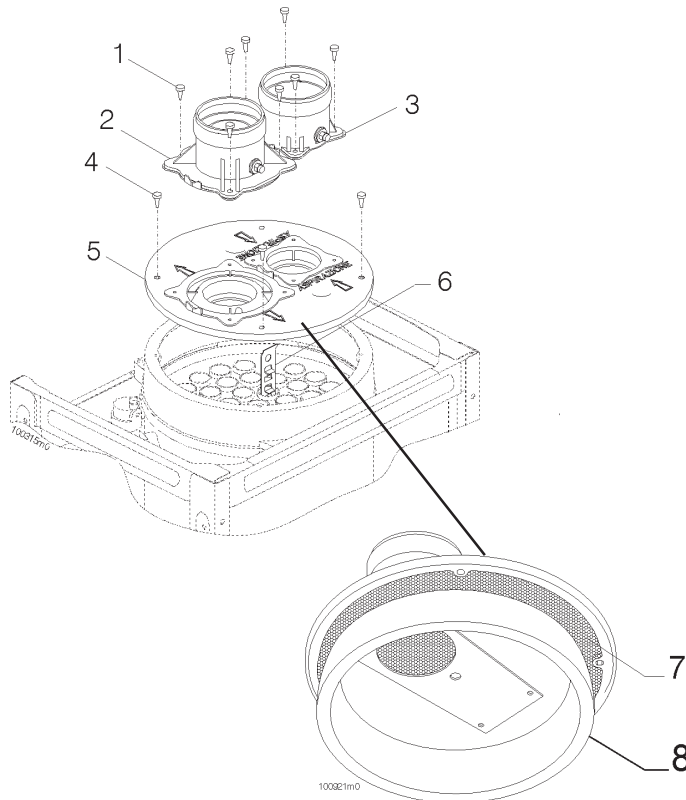

**Figure 46 - Disassembling the upper part of the heat exchanger**

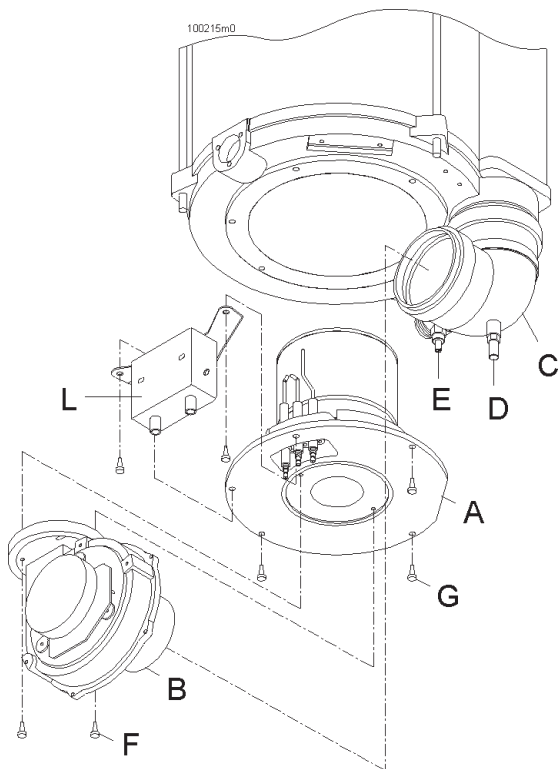

**Figure 47 - Disassembling the lower part of the heat exchanger**

### 4.1 - General cautions



**CAUTION !!!** Maintenance must be performed by a qualified installer, service agency or the gas supplier. Maintenance should be carried out at least once a year, before the start of the winter season

### 4.2 - Cleaning the burner and the heat exchanger (flue-gas side)

To correctly clean the burner and the heat exchanger (flue-gas side) proceed as follows (referring to figures 46 and 47):

- disconnect the heater from the electricity supply;
- shut off the gas supply;
- remove the heater panels;
- remove blower "B";
- disconnect the cables from the ignition and detection electrodes;
- disassemble burner "A";
- in the opening created by removing the burner, place a collector for the soot that may drop from the combustion chamber;
- disconnect the intake and discharge pipes from the heater, by means of the fittings "2" and "3";
- remove the top cover "5". Be careful with the seal between the combustive air circuit and the flue gas circuit;
- remove turbulators "6";
- pass a cylindrical brush, with plastic bristles, inside the flue gas pipes (the pipes in which turbulators "6" were installed) and brush turbulators "6";
- using a vacuum cleaner, remove the unburnt residues from the burner and from the ignition and flame control electrodes. Also vacuum the inside of the combustion chamber;
- clean the surface of burner "H" on which combustion takes place. This surface must first be washed with running water, then blown with compressed air at a pressure between 45 and 116 psi (3 and 8 bar);



**CAUTION !!!** Clean the burner in a position that avoids the risk of water splashing on the heater and/or on any electrical appliance or equipment that is vulnerable to moisture and/or water.

- clean air filter "7";
- reassemble the components, carrying out the above steps in reverse order;
- open the gas cock;
- reconnect the normal electricity supply;
- check for any gas leaks between the fittings that were removed previously, and in particular the connection of fan "B" and burner "A"

## 4 - MAINTENANCE

---

### 4.3 - Burner flame

Periodically check the appearance of the burner flame. It should be uniformly distributed over the entire surface of the burner, it should be light blue in color, and the surface where combustion takes place should be black with incandescent red spots.

### 4.4 - Safety relief valves

If the safety relief valves discharge periodically, this may be due to thermal expansion in a closed water supply system.

Contact the water supplier or local plumbing inspector on how to correct this situation. Do not plug the safety relief valves.

### 4.5 - Flue gas discharge

Periodically check the state of the flue gas discharge and air intake system

Check and clean any filters installed on the air intake terminal. Inspect the entire flue gas discharge line for any foreign matter (bees' nests, birds' nest, etc.) To determine any blockage in the venting check the pressure at the burner (see chapter 3.32) if the pressure is low there may be an obstruction in either the flue gas discharge or air intake pipe.

### 4.6 - Combustible material

Check that the room where the water heater is installed is free from combustible materials, gasoline or other flammable vapors and liquids

### 4.7 - Draining the heating side of the heater

To drain the heating side of the heater proceed as follows:

- turn off the heater;
- turn on the domestic hot water to cool the heater until the temperature indicated by the thermometer is less than 104°F

(40°C);

- close the main cold water supply valve;
- remove the cover panels (see chapter 3.28);
- connect a rubber hose to the heating drain valve "12" (see figure 26) and place the opposite end in a drain.
- open the drain valve "12";
- open the radiator air vents. Start from the radiators positioned highest and then continue with the lower ones.
- After draining all the water, close the radiator air vents and the drain valve "12";



**CAUTION !!!** Do not recover and/or reuse the water drained from the heating circuit for any purpose whatsoever, as it may be contaminated.

### 4.8 - Draining the domestic side of the heater

To drain the domestic side of the heater, proceed as follows:

- close the main domestic cold water supply valve of the home;
  - open all the hot and cold water faucets in the house;
- make sure that at least one of these valves is at a lower level than the heater.



**CAUTION !!!** before the system can be reused, it must be filled by following the procedure described in chapter 3.25, being sure, after having filled the system, to run the domestic hot and cold water for approximately 1 minute from every valves in the home. This is necessary to flush the system of any water contaminated by the heating circuit.



# IMPORTANT INFORMATION FOR THE USER

### - What to do when the smell of gas is present

- Turn the gas cock off and ventilate the room.
- Call a licensed authorized technician and, if necessary your local gas company.
- Follow the gas supplier's instructions.
- If you cannot reach your gas supplier; call the fire department.

- If water is leaking from the domestic water side:

- turn off the main cold water supply valve
- call a licensed authorized technician.

- In case of malfunction or improper operation, turn off the heater. The user must neither replace nor repair any parts.

- Should overheating occur or the gas supply fail to shut off, turn off the gas valve service switch to the heater.

- A routine maintenance contract, with a licensed authorized technician, will guarantee the heater works properly as well as ensuring a longer life.

- The user must call in a licensed authorized technician to carry out necessary routine maintenance on the heater at least once a year, before it is used for central heating.

- The technician will explain to the user how the heater works and how to operate it.

- The user must know how to fill (see chapter 3.25) and drain (see chapter 4.7 and 4.8) the circuit; he must also know how to control and correct if necessary the pressure in the central heating system (see chapter 3.25).

- After reopening the main gas cock, always wait a few minutes before switching the heater on.

- Do not leave the heater switched on unnecessarily when it will not be used for prolonged periods; in such cases, close the gas cock and turn off the electrical

power switch. Refer to the instructions in chapter 5.14 if there is risk of freezing.

- Do not touch the flue gas discharge pipe during operation of the heater and for some time afterward, as it is very hot.

- Use a damp cloth for cleaning the heater jacket. Do **not** use any abrasive detergents.

- Prior to ignition, it is necessary to carry out a few checks.

- Check that the appliance is electrically connected to a voltage of **115V 60Hz**. Grounding is compulsory likewise the installation of a switch with fuse immediately upstream from the heater.
- Check that the heater is connected properly to the flue, it must not be clogged. The height and cross section must both be adequate.

## 5 - USE

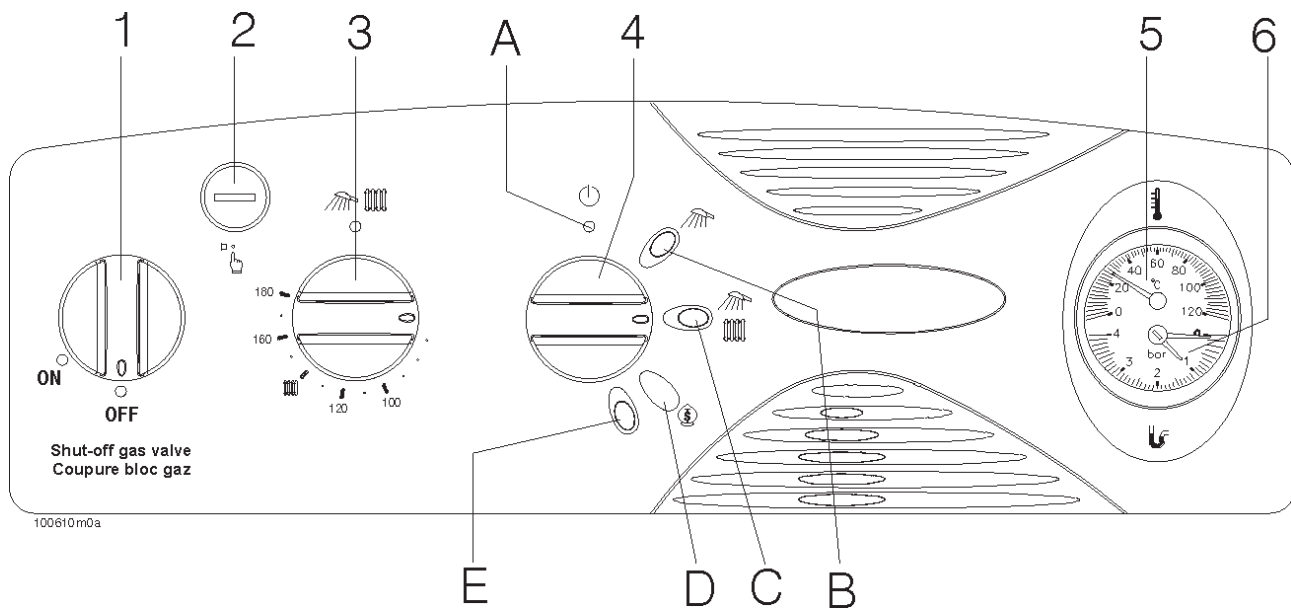

- 1 - Gas valve service switch
- 2 - High limit thermostat reset button
- 3 - Heater temperature control knob
- 4 - multifunction selector:
  - A - OFF position
  - B - Summer position, only DHW (green light ON)
  - C - Winter position. DHW and space heating only when "C" orange light is ON
  - D - Winter position, for safe money. DHW and space heating only when "C" orange light is ON
  - E - Reset ignition module
- 5 - temperature gauge
- 6 - pressure gauge

Figure 48 - Instrument panel

### 5.1 - Control panel

All references to controls from this point onward, unless specified otherwise, are referring to figure 48.

### 5.2 - Ignition procedure

- Open the gas cock;
- Switch on the electrical on/off switch
- Rotate selector "4" to the desired position (summer, "B" or winter, "C" or "D").
- Set the heater temperature control "3" to between 140° and 150°F (60° and 65°C).

The ignition module will cause the burner to ignite.

If the burner fails to ignite within 5 seconds, the heater automatically

makes a second attempt; if it again fails to ignite the heater will go into a lock-out condition and the red indicator "E" illuminates, to indicate that the heater is in lock-out. Turn knob "4" counterclockwise to position "E" to reset ignition module. Only a brief pause is required on position "E", and selector "4" will automatically return from position "E" to position "D". The heater will automatically attempt to ignite again.

**If the burner goes out after a few seconds of operation and the lock-out indicator "E" illuminates, it means that the electrical line-neutral polarity has been inverted.**



**CAUTION!!!** If the lock-out condition reoccurs frequently, call a qualified technician to have the heater repaired. Do not attempt to repair the heater yourself.

### 5.3 - Summer operation

To disable the heating function for a prolonged period, leaving only the sanitary hot water function, turn selector "4" to the summer setting (position "B") and adjust the heater temperature control "3" to between 120° and 130°F (50 and 55 °C).

### 5.4 - Winter operation

For winter operation, there are two possible positions of selector "4": "C" and "D".

In position "C" the heater always operates at maximum input rate. In position "D" the heater operates

## 5 - USE

at minimum input rate, in order to conserve energy.

To use the heater more efficiently, it is recommended to set selector "4" to position "D". If the winter is particularly cold, and the desired temperature inside the home can no longer be maintained, set selector "4" to position "C". During winter operation, both the heating and the sanitary hot water functions are active.

### 5.5 - Adjustments for winter operation

To adjust the heater for winter operation, proceed as follows:

- Set the temperature control thermostat "3" to between 140° and 150°F (60° and 65°C).
- Rotate the selector "4" to position "D" or "C", as explained in the preceding chapter.

Water is circulating inside the radiators by means of a pump installed inside the heater.

**The circulation pump runs only when the temperature inside the heater exceeds 140°F (60°C)** approximately and selector "4" is in position "C" or "D".

The pump may make some noise when it first starts. This is due to the presence of residual air inside the heating system, and goes away by itself without any action. In any case, check that the air vent cap (figure 1, detail 3) is partially unscrewed.

### 5.6 - Room thermostat

To control the room temperature and for improved energy conservation, we recommend installing a time-programmable thermostat (a device that can turn the heating on and off and/or lower or increase the room temperature according to the time of day). For the installation of such a unit, call a qualified technician.

The heater is designed to support connection to devices of this type.

### 5.7 - Resetting the Ignition Module

The ignition module, (fig.1, item 9), carries out numerous checks on heater functioning: on the burner and on the flame detection system. When the ignition module detects that one of these components is malfunctioning, it stops the heater. When the heater goes into the lock-out state, the indicator "E" illuminates.

To restart turn knob "4" in a counterclockwise direction to position "E". Only a brief pause is required on position "E", and selector "4" automatically returns from position "E" to position "D". If this operation has been done and if the heater does not start up or if this situation repeats often, call a licensed authorized personnel.

### 5.8 - Low water cut-off device

This device (see figure 26) is triggered when the water pressure inside the heating circuit (indicated by pressure gauge "6"), drops below 8 PSI (0.5 bar). When this occurs, indicator "E" illuminates and the heater shuts off. To restore normal functioning, the pressure gauge "6" reading must be brought back above 15 PSI (1 bar) To do this, follow the instructions given in paragraph 3.25.

### 5.9 - Manual Reset High-Limit Thermostat

This device turns the burner off completely if heater temperature exceeds 210°F (99°C). The user can detect this because the burner will not turn on even if the heater temperature is low and the red light indicator "E" is ON.

To restore the heater to its normal functioning condition follow this sequence:

- allow the heater to cool down to 104°F (40°C);
- unscrew and remove the protection cap of high limit thermostat reset button "2";
- press the button. Use a pen or a

skinny object to manually reset (the high limit thermostat will not reset unless the button is completely pressed).

If the high limit thermostat continues to trigger, call a licensed authorized personnel.

### 5.10 - Heating Circulator Pump

The circulator pump will **only** start working when heater temperature reaches approximately 140°F (60°C) and selector "4" is in the "C" or "D" position.

Initially, the circulator pump might make noises, which are due to pockets of air left inside the water circuit; they will disappear soon without having to do anything. In any case, check that the cap on the automatic air vent, (fig. 1, item 3) is open.

### 5.11 - Temperature-Pressure gauge

The temperature-pressure gauge "5" and "6" is a dual device that measures:

- the internal temperature of the heater "5" (thermometer);
- the pressure of the heating circuit "6" (manometer)

### 5.12 - Gas valve service switch

This service switch "1" is used by a service technician to prevent the gas valve from operating electrically.

Should overheating occur or the gas supply fail to shut off, turn "OFF" the gas valve service switch "1".

### 5.13 - Shut-off procedure

If the heater is to be shut-off for a relatively brief time (a few weeks and there is no risk of freezing) simply place selector "4" in the off position "A".

If there is the risk of freezing during your absence, leave the heater with selector "4" in position "D" and the heater temperature control "3" set to 150°F (65°C).

If there is a room thermostat

installed, make sure it is programmed to start the heater when the room temperature drops below 47°F (8°C)

If the heater will not be used for a prolonged period (over one year) we recommend draining the heating and domestic circuit using the procedure described in chapter 4.7 and 4.8, and closing gas supply cock.

### 5.14 - Precautions against freezing

The heater is not protected against freezing. If the heater is switched off and there is the possibility of exposure to temperatures below 32°F (0°C), the system must be drained as follows:

- Carry out the procedure for draining the domestic water circuit described in chapter 4.8.
- Carry out the procedure for draining the heating circuit described in chapter 4.7.

### 5.15 - Flue gas discharge

This heater has high efficiency and emissions with low pollution levels. For this reason, especially in the winter, white smoke will come out of the discharge pipe. This is not a cause for worry, as it is only steam which condenses in contact with the cold air.

### 5.16 - Abnormalities during operation

If the heater fails to start, check that:

- The gas supply is open;
- The main electrical power switch is in the on position;
- The selector “4” is not in the off position “A”;
- The heater is not in the lock-out state (red light “E” is ON)

If during winter operation the domestic hot water works but the heating doesn't, check that:

- The room thermostat is programmed for a higher temperature than that of the

room where it is installed, and that it is programmed to call for heating (setback thermostats)

- any valves installed on the heating supply and return connections are open;
- Selector “4” is turned to position “C” or “D” to call for heating;
- Selector “3” is at least at 140°F (65°C);
- Open the radiator valves to bleed the air;



**CAUTION!!!** If after these checks the heating system is still cold, do not attempt to repair it but call a qualified technician.

# 6 - TROUBLESHOOTING

## 6.1 - Troubleshooting Sequence of operation to light the burner

All references to controls in this schema, unless specified otherwise, are referred to figure 48.

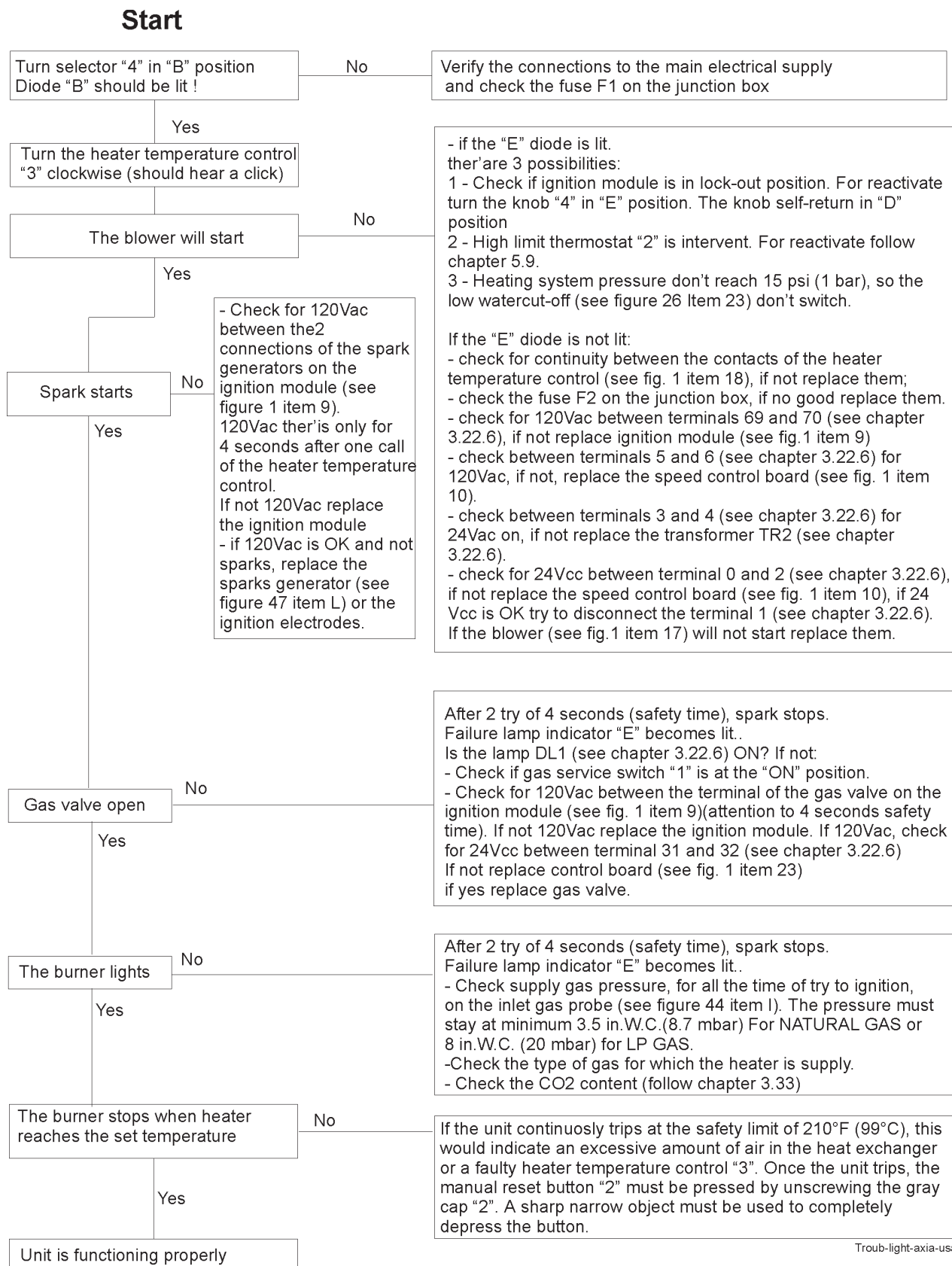

# 6 - TROUBLESHOOTING

## 6.2 - Troubleshooting Sequence of Operation for a Call for Heat

All references to controls in this schema, unless specified otherwise, are referred to figure 48.

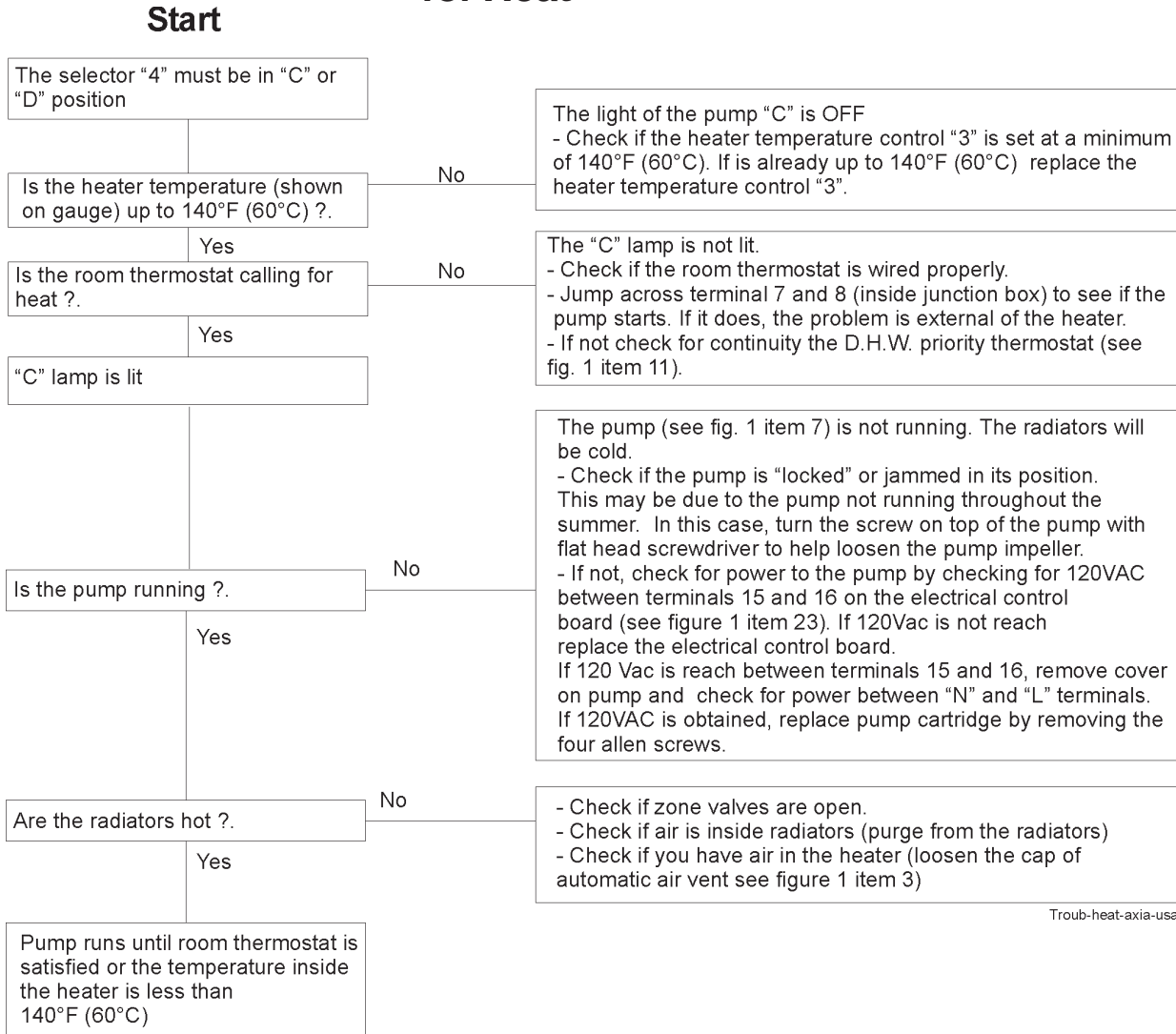

## 6.3 - Troubleshooting Sequence of Operation for a Call for D.H.W.

All references to controls in this schema, unless specified otherwise, are referred to figure 48.

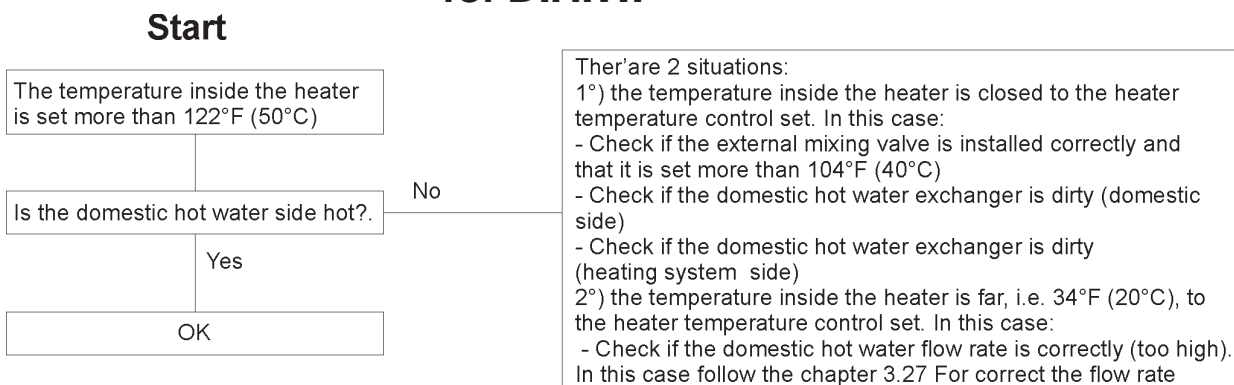

## 7 - SPARE PARTS

---

Ref. to	Descriptions	P/N for AXIA 20E	P/N for AXIA 29E
Figure 1			
3	Automatic air vent	61206002	61206002
4	Expansion tank	62202001	62202001
5	Gas valve	61201032	61201032
6	Safety relief valve	61205010	61205010
7	Circulator pump	62301025	62301025
8	Heat exchanger	62644201	62644203
9	Ignition module	62110064	62110064
10	Speed control board	60507034	60507034
11	Domestic hot water priority thermostat	62101030	62101030
12	Domestic hot water tube	62624073	62624073
13	Domestic cold water tube	62624086	62624086
15	Temperature-pressure gauge	62115002	62115002
16	Multifunction selector	60507044	60507044
17	Blower	62644009	62644009
18	Heater temperature control	62101044	62101044
20	High limit thermostat	62101029	62101029
21	Gas valve service switch	60506026	60506026
23	Electrical control board	60507039	60507039
6 (figure 46)	Turbulator	60416012	60416012
23 (figure 26)	Low water cut-off	62113016	62113016
H (figure 47)	Burner	62644005	62644010
L (figure 47)	Spark generator	60510015	60510015
M and N (figure 47)	Ignition cables (P/N for each)	60504078	60504078
O (figure 47)	Detection cable	60504137	60504137
P (figure 47)	Left ignition electrode	60505017	60505017
Q (figure 47)	Right ignition electrode	60505016	60505016
R (figure 47)	Detection electrode	60505018	60505018
TR1 (chapter 3.22.5 and 3.22.6)	TR1 transformer	60510013	60510013
TR2 (chapter 3.22.5 and 3.22.6)	TR2 transformer	60510014	60510014

Spare parts are available from your local authorized wholesale distributor.  
For a location of the one nearest you call Embassy Industries, Inc. at 631-694-1800.

# 8 - TECHNICAL DATA

## 8.1 - Table of the technical data

Heater model		AXIA 20E	AXIA 29E
CSA certification number		1286455 (LR 114696)	1286455 (LR 114696)
Heating and domestic nominal input rating	Btu/hr (kW)	90,000 (26.4)	160,000 (46.9)
Heating and domestic nominal output rating	Btu/hr (kW)	76,500 (22.4)	136,000 (39.9)
Min. heating input rating	Btu/hr (kW)	50,000 (14.7)	90,000 (26.4)
Min. heating output rating	Btu/hr (kW)	42,500 (12.5)	76,500 (22.4)
Thermal efficiency	%	85	85
Combustion efficiency	%	87	87
Minimum supply natural gas pressure	in W.C. (mbar)	3.5 (8.7)	3.5 (8.7)
Maximum supply natural gas pressure	in W.C. (mbar)	10.5 (24.9)	10.5 (24.9)
Minimum supply LP gas pressure	in W.C. (mbar)	8 (19.9)	8 (19.9)
Maximum supply LP gas pressure	in W.C. (mbar)	13 (32.4)	13 (32.4)
Manifold natural gas nominal pressure	in W.C. (mbar)	2.17 (5.5)	1.89 (4.8)
Manifold natural gas minimum pressure	in W.C. (mbar)	0.79 (2)	0.79 (2)
Manifold LP gas nominal pressure	in W.C. (mbar)	2.28 (5.8)	1.97 (5)
Manifold LP gas minimum pressure	in W.C. (mbar)	0.79 (2)	0.79 (2)
Burner natural gas flow rate	gal/hr (m3/h)	654 (2.48)	1177 (4.38)
Burner LP gas flow rate	gal/hr (m3/h)	258 (0.98)	457 (1.73)
Injector natural gas diameter	mm/100	500	900
Injector LP gas diameter	mm/100	390	540
Maximum heating temperature	°F (°C)	180 (82)	180 (82)
Minimum heating temperature	°F (°C)	140 (60)	140 (60)
Maximum heating pressure	PSI (bar)	30 (2)	30 (2)
Minimum heating pressure	PSI (bar)	7.3 (0.5)	7.3 (0.5)
Expansion tank	gal (lit.)	2.64 (10)	2.64 (10)
Maximum domestic temperature	°F (°C)	180 (82)	180 (82)
Minimum domestic temperature	°F (°C)	100 (38)	100 (38)
Maximum domestic pressure	PSI (bar)	150 (10.3)	150 (10.3)
Minimum domestic pressure	PSI (bar)	1 (0.07)	1 (0.07)
DHW output with rise at 75°F (42°C) Continuous	gal/min (lit./min)	2.1 (7.7)	3.7 (13.6)
*DHW output with rise at 75°F (42°C) Intermittent	gal/min (lit./min)	2.6 (9.8)	4.6 (17.4)
Electrical supply		120 V, 60 Hz	120 V, 60 Hz
Amperes less than	A	2	2
Split vent-air intake features			
Diameter	in (mm)	3.15 (80)	3.15 (80)
Maximum length	ft (m)	100 (30,5)	100 (30,5)
Minimum length	ft (m)	1 (0.3)	1 (0.3)
Equivalent length of one 90° elbow	ft (m)	3 (0.9)	3 (0.9)
Concentric vent air intake features			
Diameter air-intake tube	in (mm)	3.94 (100)	3.94 (100)
Diameter flue discharge tube	in (mm)	2.36 (60)	2.36 (60)
Maximum length coaxial tube	ft (m)	19 (5.8)	19 (5.8)
Minimum length coaxial tube	ft (m)	1 (0.3)	1 (0.3)
Equivalent length of one 90° elbow	ft (m)	3 (0.9)	3 (0.9)
Flue temperature	°F (°C)	266 (130)	266 (130)
CO2 content with natural gas	%	9	9
CO2 content with LP gas	%	11.5	11.5
NOx content (at 0% of O2)	ppm	<30	<30
CO content (at 0% of O2)	ppm	<20	<20
Dimensions			
Height (H)	in (mm)	35.4 (900)	35.4 (900)
Width (L)	in (mm)	18.9 (480)	18.9 (480)
Depth (P)	in (mm)	15.35 (390)	15.35 (390)
Expansion tank capacity	gal (lit.)	2.64 (10)	2.64 (10)
Weight	lb (kg)	140 (65)	143 (67)

\*Intermittent flow, is a tapping of maximum 10 minutes. After you must wait 3 minutes to charge boiler again.

# 8 - TECHNICAL DATA

## 8.2 - Curves of residual head for central heating system

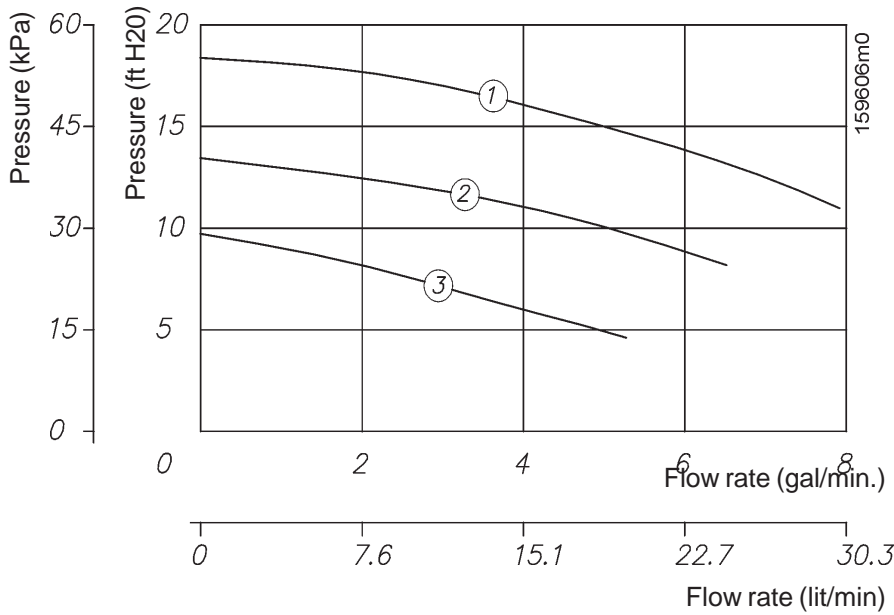

Where:

- 1 = first speed
- 2 = second speed
- 3 = third speed

## 8.3 - Curves burner pressure-input rating

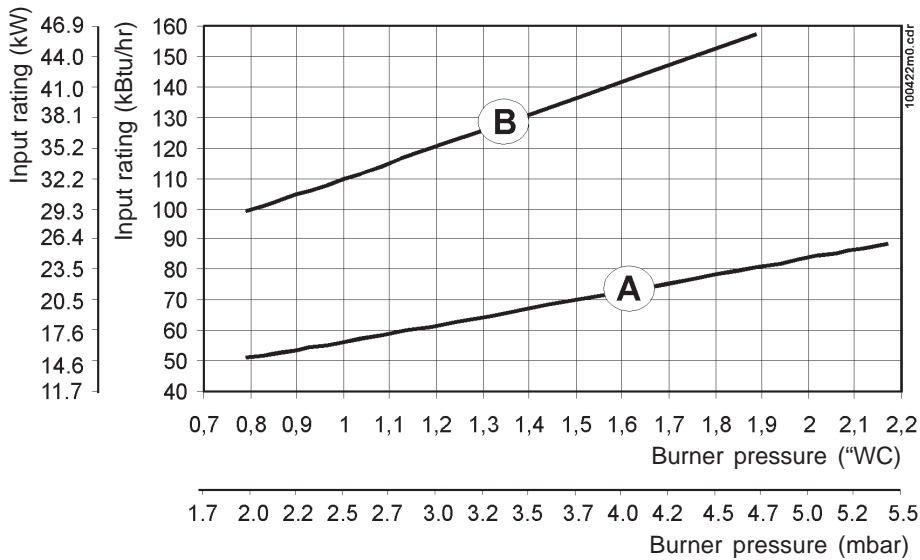

Where:

- A = AXIA 20E
- B = AXIA 29E

## 8.4 - Curves Efficiency-input rating

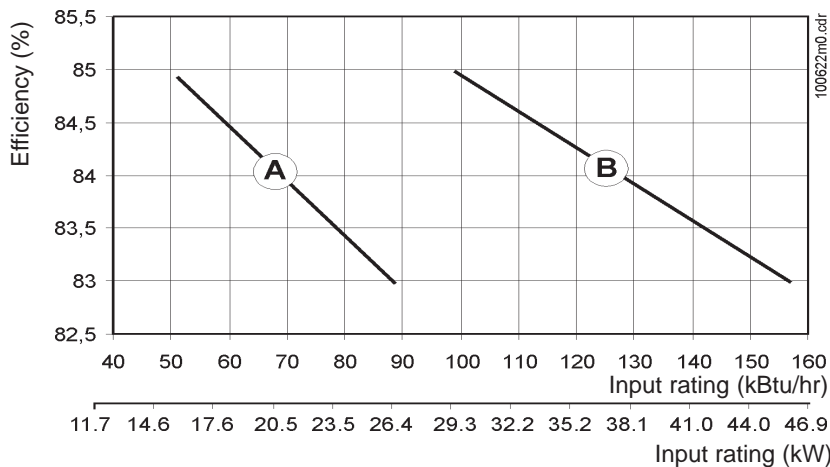

Where:

- A = AXIA 20E
- B = AXIA 29E

FOR TECHNICAL SUPPORT CALL:



Embassy Industries, Inc.  
300 Smith Street  
Farmingdale, NY 11735  
PH - 631-694-1800  
Fax - 631-694-1832  
[www.embassyind.com](http://www.embassyind.com)  
[sales@embassyind.com](mailto:sales@embassyind.com)

MANUFACTURED BY:



COSMOGAS s.r.l.  
Via L. da Vinci 16 - 47014  
MELDOLA (FC) ITALY  
[info@cosmogas.com](mailto:info@cosmogas.com)  
[www.cosmogas.com](http://www.cosmogas.com)



ISO 9001  
Certified  
Quality System