



FireGenie™

North American Version

REMOTE CONTROL INSTALLATION & OPERATING INSTRUCTIONS



The FireGenie™ Remote Control is tested safe when installed in accordance with this installation manual. It is your responsibility to read all instructions before starting installation and to follow these instructions carefully during installation.

The FireGenie™ Remote Control is carefully engineered and MUST be installed only as specified. If you modify it or any of its components, you may possibly cause a fire hazard.

The FireGenie™ Remote Control MUST be installed by a qualified installer.

FCC Requirements

Warning: Changes or modifications to this unit not expressly approved by the party responsible for compliance could void the user's authority to operate the equipment. This equipment has been tested and found to comply with the limits for a Class B digital device, pursuant to Part 15 to the FCC Rules. These limits are designed to provide reasonable protection against harmful interference in a residential installation. This equipment generates, uses, and can radiate radio frequency energy and, if not installed and used in accordance with the instructions, may cause harmful interference to radio communications. However, there is no guarantee that interference will not occur in a particular installation. If this equipment does cause harmful interference to radio or television reception, which can be determined by turning the equipment off and on, the user is encouraged to try to correct the interference by one or more of the following measures:

- Reorient or relocate the receiver antenna.
- Increase the separation between the equipment and receiver.
- Connect the equipment into an outlet on a circuit different from that to which the receiver is connected.
- Consult the dealer or an experienced radio TV technician for help.

Canadian Equipment Requirements

This digital apparatus does not exceed the (class A/class B)* limits for radio noise emissions from digital apparatus set out in the Radio Interference Regulations of the Canadian Department of Communications.

This device complies with RSS-210 of Industry and Science Canada. Operation is subject to the following two conditions; (1) this device may not cause interference, and (2) this device must accept any interference, including interference that may cause undesired operation of the device.

All wiring should be done by a qualified electrician and shall be in compliance with local codes and with the National Electric Code ANSI/NFPA No. 70-current (In the United States), or with the CSA C22.1 Canadian Electric Code (in Canada).

TABLE OF CONTENTS

Matching Remote Control & Receiver ID Code	4
Remote Control Keypad	5
Remote Control Screen Display (LCD)	6
Remote Control - Basic Functions	6
Switching the Remote ON and OFF	6
Setting Time & Day	7
Receiver Operation	7
Manual Mode	8
Auto Mode	8
Program Mode	9
Setting the Program Mode	10
Installing the Receiver	15
Installing to a Wall Mount	15
Installing to a Fireplace	16
Troubleshooting	18
Battery Replacement	18
Special Conditions in Program Mode	19
Displaying Temperature in Celsius or Fahrenheit	19

IMPORTANT

- * The battery light (BAT. LOW) on the Receiver will NOT turn on when the Receiver is set to “ON” or “OFF”.
- * When the Receiver is set to “REMOTE” the battery light will flash (1 blink per second). Battery power is sufficient.
- * If the battery light (BAT. LOW) starts to flash rapidly (3 blinks per second), this is an indication that the battery power is low and they should be replaced.
- * The Remote Control only responds to a Remote Control with a matching ID Code. See page 4 for details.

MATCHING REMOTE CONTROL & RECEIVER ID CODE

The Remote Control handset has a set of unique ID codes that is pre-programmed into its memory. This set of ID codes helps to differentiate one Remote Control handset from another so that only the control box with a matching ID code will respond to the appropriate Remote Control handset.

To ensure the Remote Control is matched to the Receiver correctly, please follow the steps below;

1. Ensure that the pilot is lit and the pilot control knob is in the ON position at the appliance.
2. Ensure both the Remote Control and the Receiver box are switched OFF.
3. Install the 2 x AAA alkaline batteries into the Remote Control.
4. Install the 4 x AA alkaline batteries into the Remote Receiver.
5. Switch the Receiver box to the REMOTE position.
6. Press and hold the **PROG** and **PRESET** buttons simultaneously on the remote control for up to 20 seconds. During this time, the remote will display "LC" while it is transmitting codes to the receiver. Once it has successfully transmitted, the burner will come on. If it does not work the first time wait for 1 minute and repeat steps 1 - 5.
7. Release both the **PROG** and **PRESET** buttons. The remote control will revert back to normal, but the burner will still be on.
8. Press the **ON/OFF** button on the remote 2 times to turn the burner off.
9. The remote control is now programmed to the receiver and the appliance can now be operated with it.

The control box will only learn the Remote ID codes during the first 30 seconds after power is applied and will ignore this special command from the Remote Control after the first 30 seconds.

NOTE: This must only be performed by a qualified installer.

The FireGenie™ is a custom designed Remote Control system with the following features:

- * Thermostatic Control;
- * An Automatic & Manual Mode for controlling unit ON and OFF;
- * A Program Mode for programming 2 time periods per day for all days of the week.

A **Quick Reference Sticker** is available to be placed on the back of your Remote Control Handset. Place the sticker close to the very top of the remote, away from the battery opening and wall mounting bracket.

REMOTE CONTROL KEYPAD

There are 7 push buttons on the Remote Control:

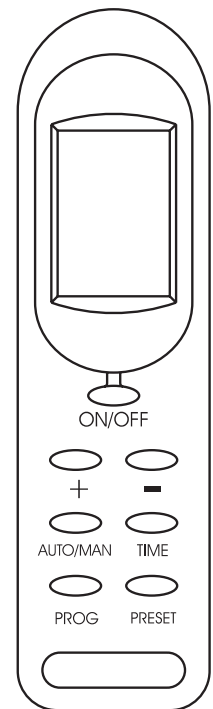

- (1) **ON/OFF** Button: Switches the Remote ON or OFF;
- (2) **“+”** Button: This is the *INCREMENT* or *HOUR* button;
- (3) **“-”** Button: This is the *DECREMENT* or *MINUTE* button;
- (4) **AUTO/MAN** Button: Toggles between *Manual*, *Auto* and *Program* mode;
- (5) **TIME** Button: Initiates the setting of the *Time and Day*;
- (6) **PROG** Button: Initiates the programming for Auto mode;
- (7) **PRESET** Button: Restores factory set programs;



Remote Control

REMOTE CONTROL SCREEN DISPLAY (LCD)

The LCD provides the following display features:

1. Flame Indication;
2. Manual & Auto Mode Indication - “MANUAL” / “AUTO”;
3. “ROOM” or “SET” Temperature Indicator;
4. Day of Week;
5. Transmit Indicator “”;
6. System Status Indicator “ON” or “OFF”;
7. Battery Low Indicator “”;
8. Programmed Mode Indication “PROG 1” / “PROG 2”;
9. Temperature Display in “°C” or “°F”;
10. Time of Day with AM, PM;

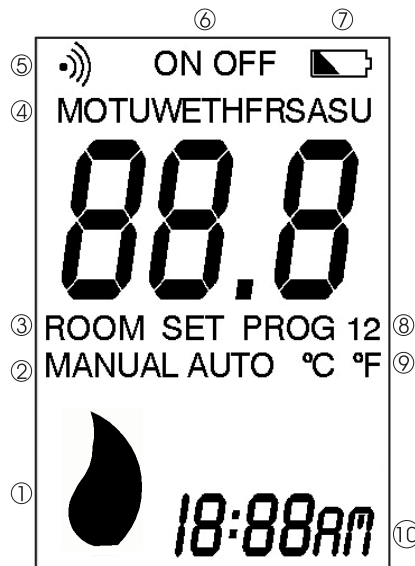

REMOTE CONTROL — BASIC FUNCTIONS

Switching the Remote ON & OFF

The **On/Off** button is used to switch the Remote Control ON or OFF.

If the Remote Control is switched OFF, pressing and releasing the **On/Off** button will switch ON the Remote Control. Once switched ON, the Remote Control will continue with its last selected operating mode, for example, *Manual*, *Auto* or *Program* mode. When the Remote Control is OFF, the LCD display continues to show the current day, time and room temperature.

Setting Time & Day

Note: The Remote Control Keypad must be “ON” in order to set the Time & Day.

Time

Press and hold the “TIME” button for 2 seconds and then use the “+” button to set the hour and use the “-” button to set the minute.

Day

Press the “TIME” button again and use the “+” or “-” button to set the day.

Press the “TIME” button once more to record the setting.

RECEIVER OPERATION

The Remote Receiver has 3 operating modes, namely ON, OFF and Remote. The operating mode is selected by means of a slide switch on the front panel of the Receiver.

ON: When “ON” Mode is selected, the flame will turn ON.

OFF: When “OFF” Mode is selected, the flame will turn OFF. However, the unit can be turned ON or OFF with the standard ON/OFF switch.

Remote: When Remote Mode is selected, the Receiver will turn the flame ON or OFF depending on the setting of the Remote Control.

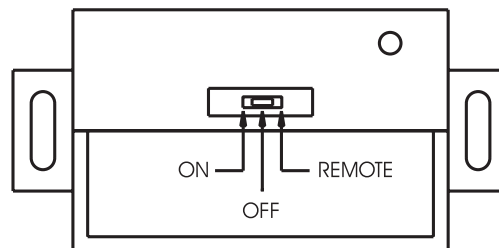

Receiver

MANUAL MODE

Note: Ensure the Remote Control has been turned ON in order to operate in this mode.

Manual mode can be selected by pressing and releasing the *AUTO/MAN* button until the symbol “MANUAL” is shown on the LCD.

In *Manual* mode, the Flame can be turned on and off using the Remote Control via the ON/OFF button.

AUTO MODE

There is a 3-minute delay built into the Remote Control. This delay will affect the “AUTO” and “PROG” modes only. Which means the unit may not respond to specific instructions instantly when in either of these 2 modes.

Note: Ensure the Remote Control has been turned “ON” in order to operate in this mode.

In Auto Mode the Remote Control operates as a thermostat to turn the fire on and off depending on what temperature setting it has been programmed to.

Auto mode can be selected by pressing and releasing the *AUTO/MAN* button until the symbol “AUTO” is shown on the LCD.

In *Auto* mode, when either the “+” or “-” button is pressed, the Set Temperature will be displayed on the LCD instead of the Room Temperature. The Set Temperature will remain displayed on the LCD for 5 seconds after the button is released and then the display will revert to show the Room Temperature. The Set Temperature can be adjusted while it is displayed using the “+” and “-” buttons.

The LCD will show the following when either the “+” or “-” button is pressed:

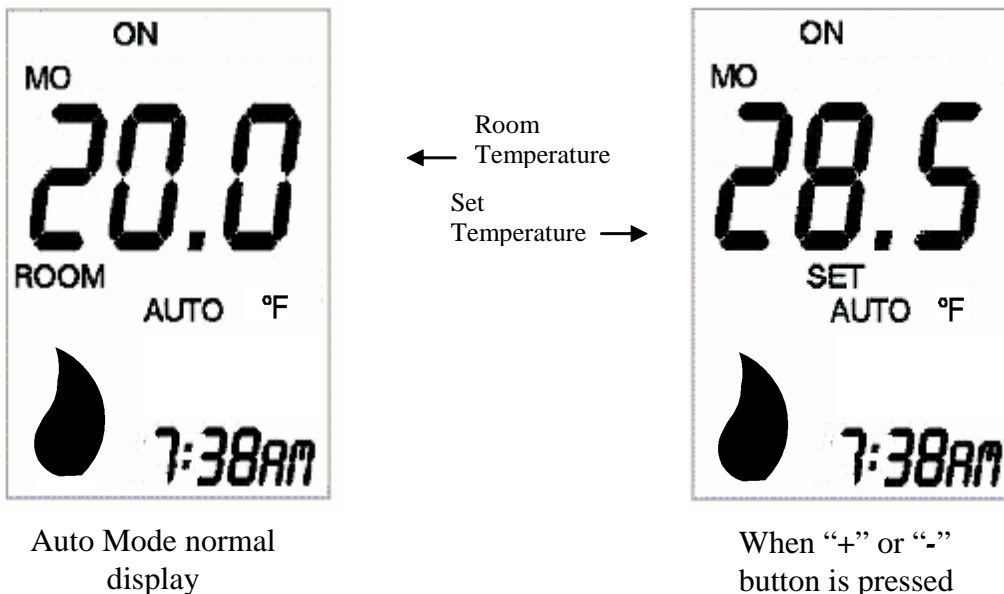

ADVANCED FUNCTION - PROGRAM MODE

Note: Ensure the Remote Control has been turned ON in order to operate in this mode.

Program mode is selected by pressing and releasing the **AUTO/MAN** button until the symbol “PROG” is shown on the LCD. The Remote Control will operate according to the settings in the 2 Time Periods programmed by the user. Refer to *Setting the Program Mode* for details.

The Remote Control has been pre-programmed with the following default factory program:

Time Period	On-Time	Off-Time	Set Temperature (°F)
1 – Mon. – Fri.	6:00 am	8:00 am	71.5
1 – Sat. – Sun.	7:00 am	10:00 am	71.5
2 – Mon. – Fri.	5:00 pm	10:00 pm	71.5
2 – Sat. – Sun.	4:00 pm	11:00 pm	71.5

By pressing and holding the **PRESET** button for 10 seconds or longer, the Remote Control’s programs will be reset to the above default factory set program.

Pressing and releasing the **PROG** button successively will allow the user to review the programmed times for each day of the week.

To exit this mode wait approximately 20 seconds after the last button is released or press the ON/OFF button twice to return to the last operating mode.

If the Time Periods have not been programmed in the Remote Control, the display will show the following:

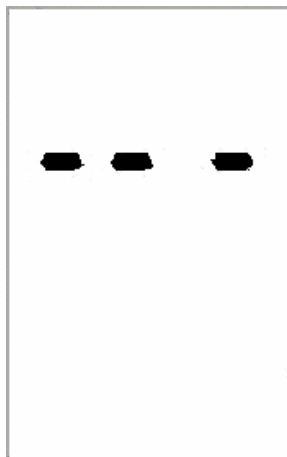

Programs have not been set.

SETTING THE PROGRAM MODE

The user can program two On-Times and two Off-Times as well as the Temperature settings for each day of the week. The **PROG** button is used to initiate the programming mode. The “+” and “-” buttons are used to adjust the time and temperature settings.

Note: The Remote Control must be “ON” in order to set the Programs.

To change or re-program your Remote Control, confirm that the Remote Control is in program mode. “PROG” will be displayed on the LCD. Hold the “PROG” button down for 2 seconds, you will see “PROG” and the Time both flash. Continue through the set-up instructions.

Follow the steps below to set the programs:

1) Programming the On-Time of Time Period 1

Press and hold the **PROG** button for 2 seconds or more to initiate the Programming mode.

The symbol “PROG 1” will flash to indicate the Remote is in Programming mode.

The On-Time for Time Period 1 will also flash. The “+” and “-” buttons can be used to adjust this time setting.

The LCD will show the current setting in Time Period 1 for Monday:

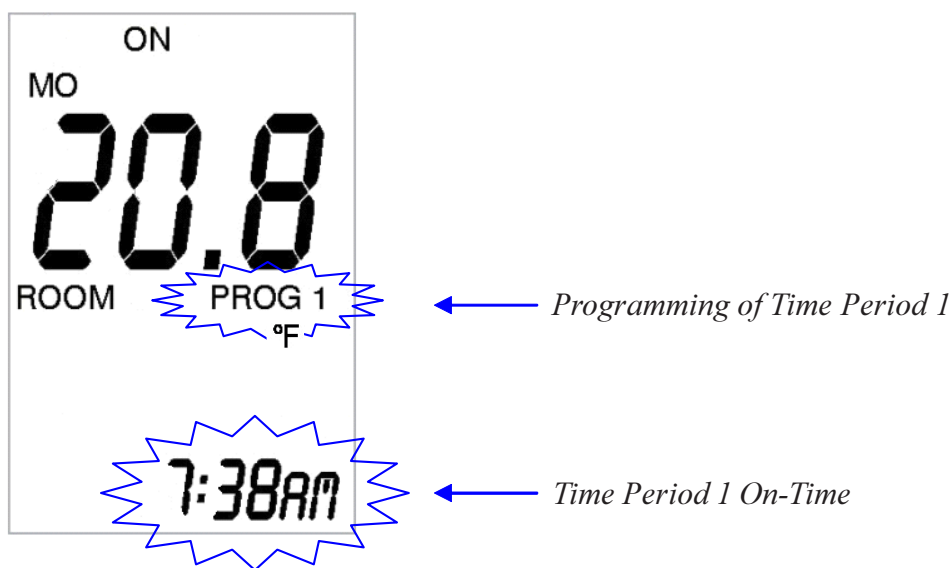

2) Programming the Off-Time of Time Period 1

Press and release the **PROG** button again to program the Off-Time for Time Period 1. Use the “+” and “-” buttons to adjust this time setting.

The LCD will show the following:

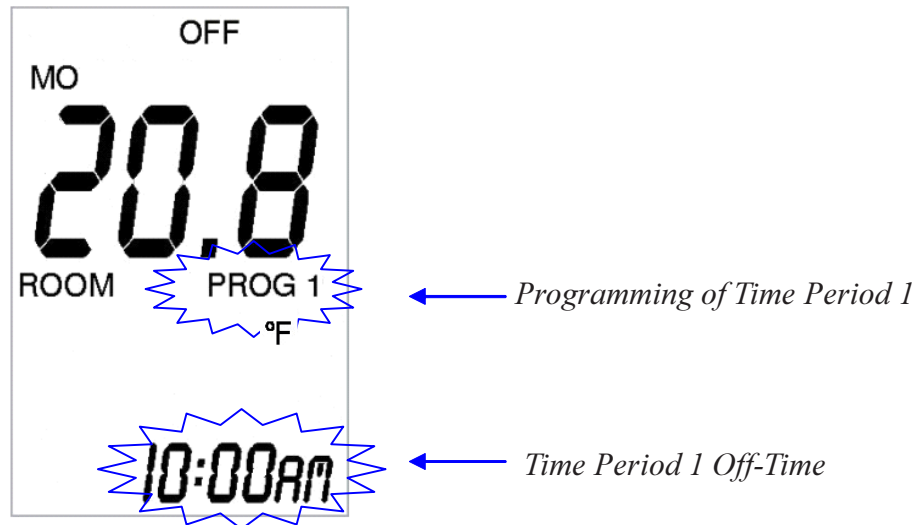

3) Programming the Set Temperature of Time Period 1

Press and release the **PROG** button again to program the Set Temperature. Use the “+” and “-” buttons to adjust the temperature setting.

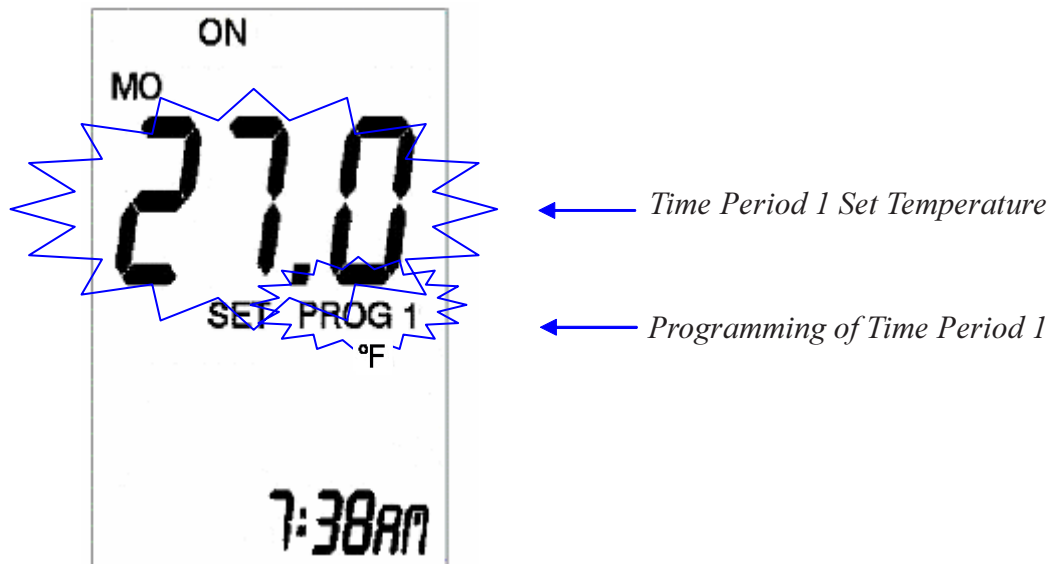

4) Programming the On-Time of Time Period 2

Press and release the **PROG** button again to program the On-Time of Time Period 2. Use the “+” and “-” buttons to adjust this time setting.

The LCD will show the following:

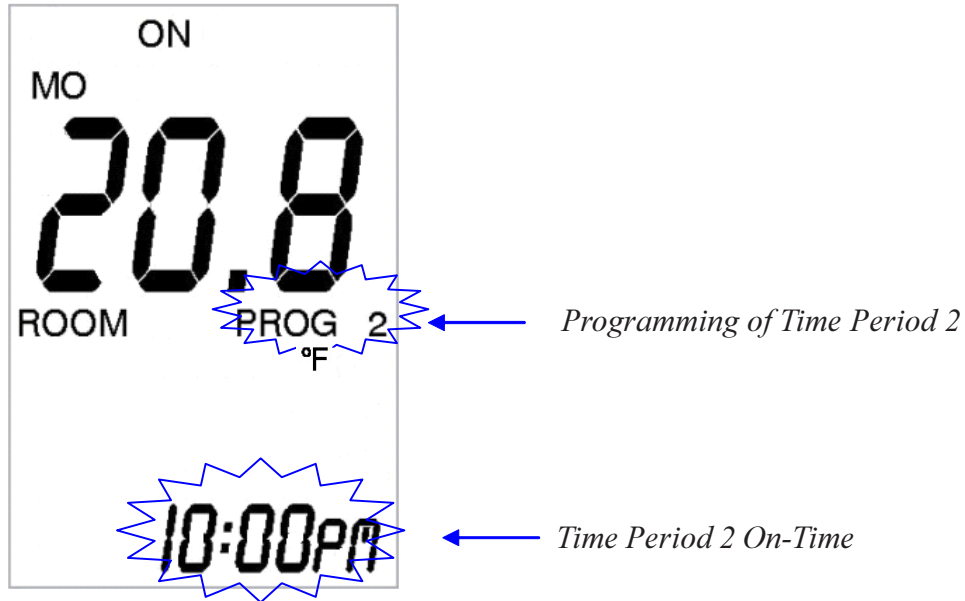

5) Programming the Off-Time of Time Period 2

Press and release the **PROG** button again to program the Off-Time of Time Period 2. Use the “+” and “-” buttons to adjust this time setting.

The LCD will show the following:

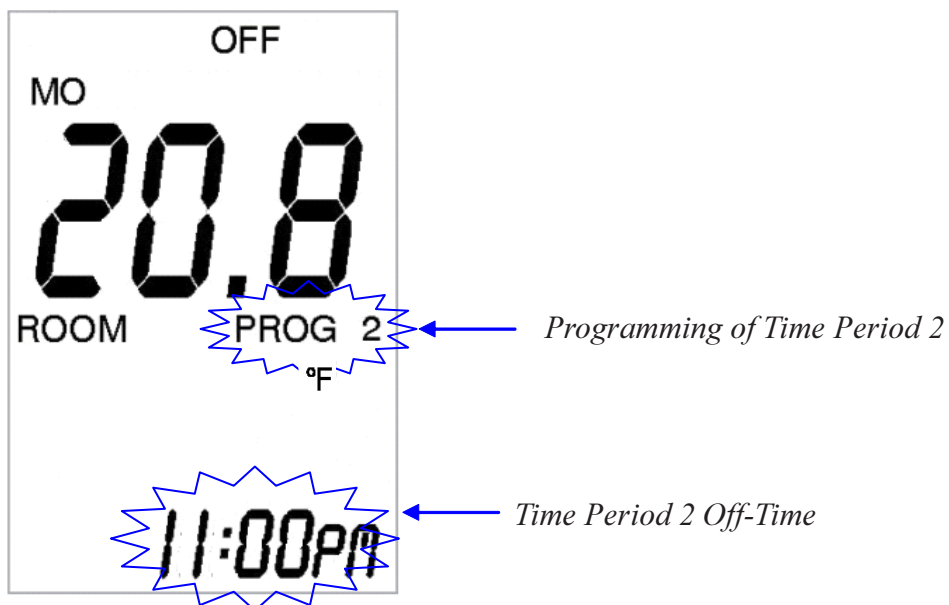

6) Programming the Set Temperature of Time Period 2

Press and release the **PROG** button one more time to program the Set Temperature of Time Period 2. Use the “+” and “-” buttons to adjust the temperature setting.

See step 7b) immediately if you would like to copy the set program over to other days of the week.

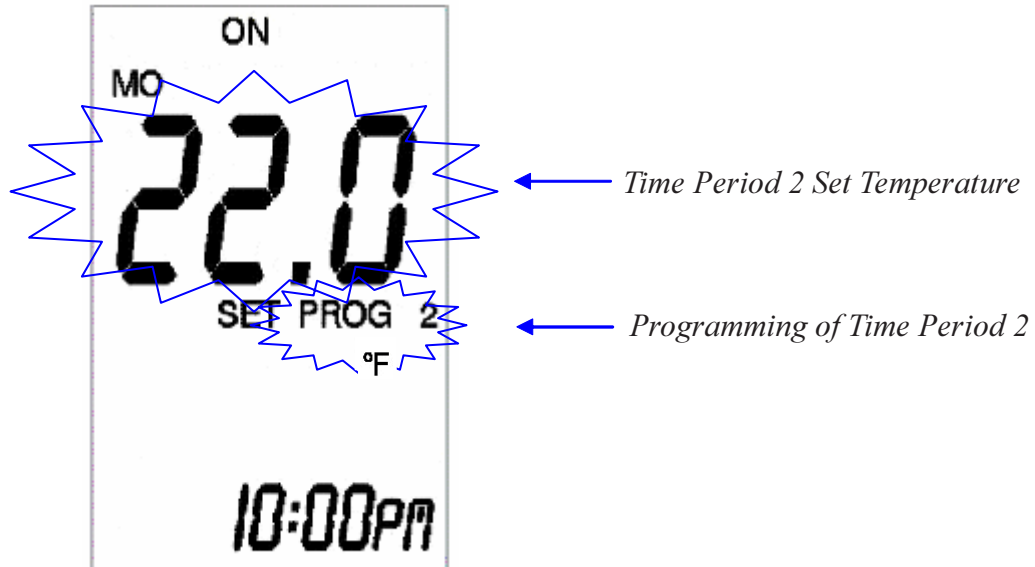

7a) Programming the Rest of the Week

Repeat steps 2 to 6 until all 7 days have been programmed.

7b) Alternatively, Copy Programs Over to the Other Days

While the Set Temperature of Time Period 2 is still flashing, pressing and holding the **PROG** button for 2 seconds or longer will initiate the copying process.

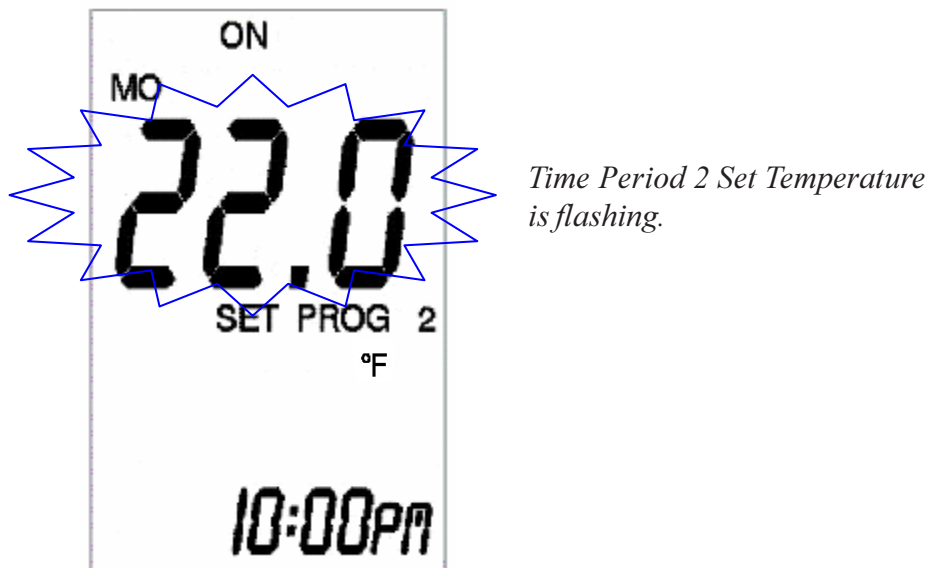

The “Day”, “Set Temperature” and “Prog 2” will all begin to flash simultaneously, indicating that Copy Mode has been activated.

Pressing and releasing the “+” button will select the Day(s) of which the program is to copy to.

Pressing and releasing the “-” button will confirm the copying process in which the original program will copy across to the selected day(s).

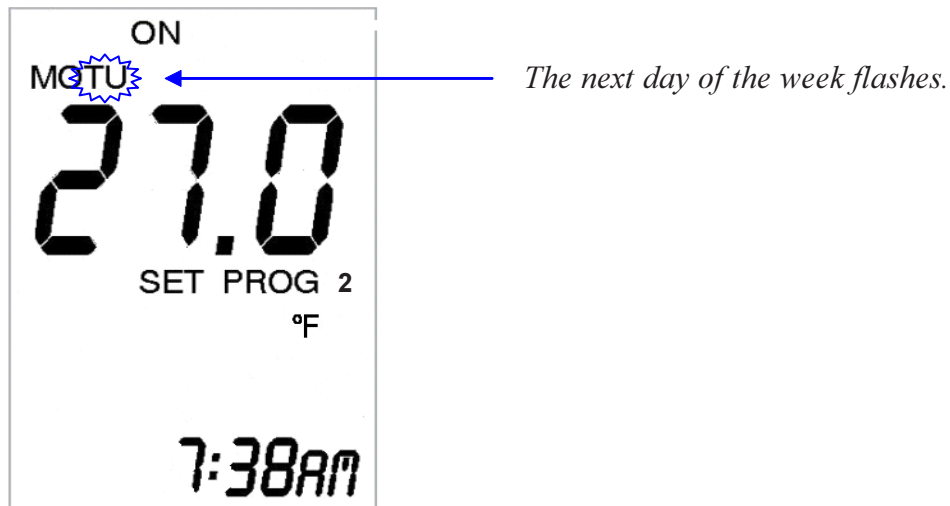

Once the programs have been copied over to the other days of the week, the Remote Control will automatically return to normal Program mode after the last button is released, after approximately 20 seconds.

8) Exiting Program Mode

There are 2 ways to exit Program Mode;

- 1) The Remote Control will automatically exit the Program mode 20 seconds after the last button is released or
- 2) By pressing the ON/OFF button twice, the Remote Control will return to the last operating mode.

INSTALLING THE RECEIVER

1. Make sure the slide switch on the Receiver is at the “OFF” position.
2. Connect the output cable of the Receiver to the valve.

Refer to the unit instruction manual for wiring details.

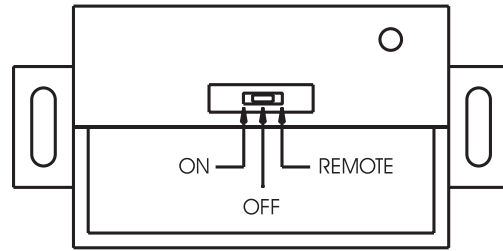

Installing the Receiver to a Wall Mount

- a. Secure the Receiver to the wall receptacle box.
- b. Use the screws provided to secure the face plate to the Receiver.

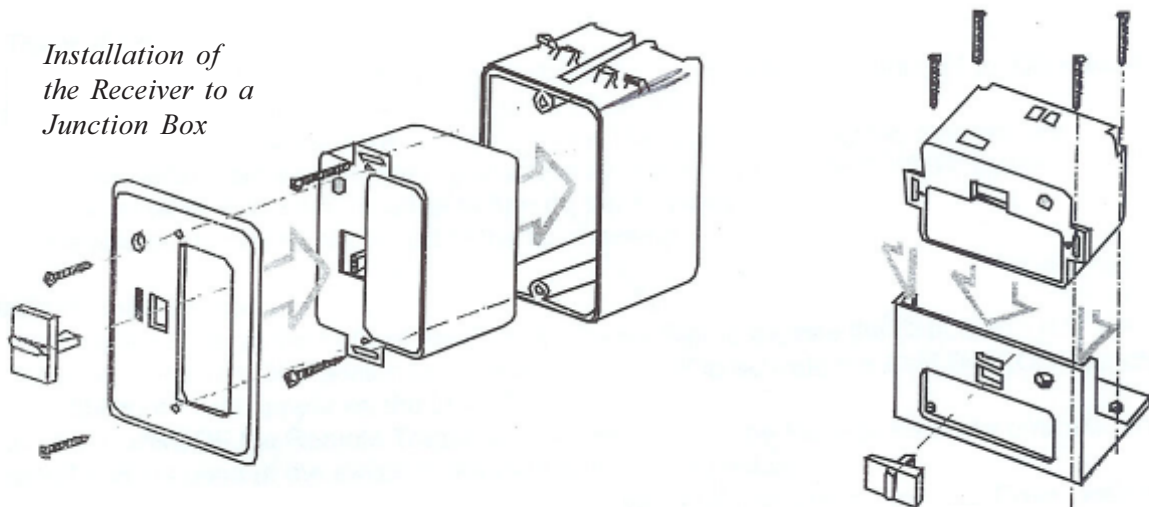

Installing the Receiver to a Fireplace

- 1) Remove Control Switch from Remote Receiver by pulling out gently.

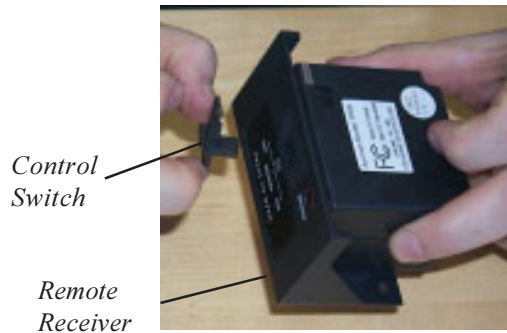

- 2) Remove spring loaded Battery Pack by pushing in and then pulling out.

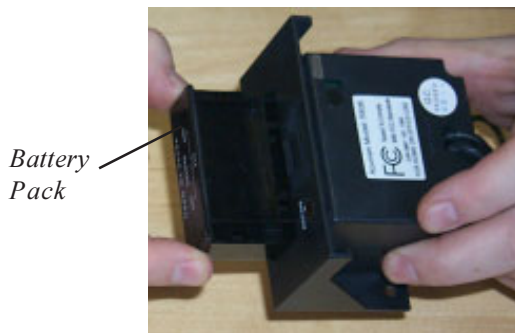

- 3) Remove Receiver from Bracket and discard bracket. (This Bracket is no longer required after this step.)

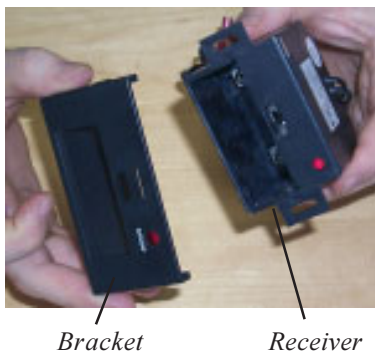

NOTE: After this step, installation of the E21 differs from the rest of the units. Please follow steps specified for the E21.

- 4) Place Heat Shield over Receiver. Be careful not to crimp wires under edge of Shield.

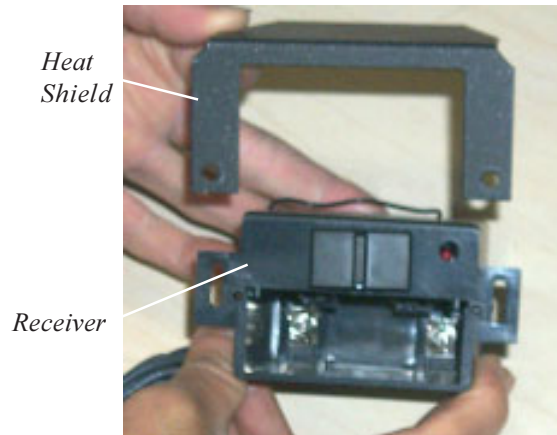

- 5) Secure Heat Shield onto Receiver with 2 x #10 x 1/2" screws. Ensure the bottom of the Heat Shield is flush with the Receiver as shown in the diagram below.



- 6) Re-install Battery Pack and Control Switch by reversing steps 2 and 1 only.

Continuation For E21 Installation Only

- 4) *Remove Bottom Glass Trim.*
- 5) *Place Remote Receiver under firebox.*



Firebox

*Remote
Receiver*

- 6) *Place Heat Shield over Receiver.*

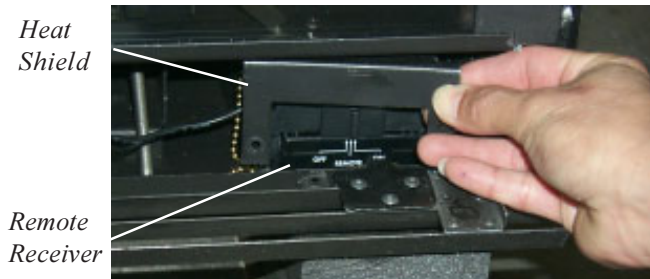

*Heat
Shield*

*Remote
Receiver*

- 7) *Secure Heat Shield with 2 screws as shown below.*

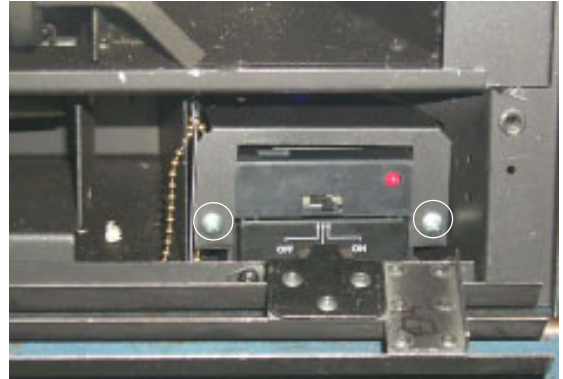

- 8) *Ensure wires do not touch base of firebox.*
- 9) *Re-install Bottom Glass Trim.*

TROUBLESHOOTING

If the Remote Control does not turn on:

- Check to see that the Receiver is in the “Remote” position.
- Ensure the batteries are correctly installed in the Receiver.
- Check the batteries for replacement.

When batteries are replaced, only the current time and day will need to be reset. The set program times are not affected.

Battery Replacement

The **Remote Control** takes 2 x AA alkaline batteries.

To replace simply remove the Cover from the back of the Remote Control, take out the old batteries and replace with new ones.

The **Receiver** takes 4 x AA alkaline batteries.

To replace, simply remove the Spring Loaded Battery pack from the Receiver by pushing in and then pulling out. Then remove the Cover from the top of the Receiver, take out the old batteries and replace with new ones.

Special Conditions in Program Mode

- If the On-Time of a Time Period matches the Off-Time of the same Time Period, the Time Period is disabled.
- If the Off-Time of the First Time Period crosses over to the On-Time of the second Time Period, the Off-Time of the first Time Period will have precedent, for example, if Time Period 1 is programmed to end at 2:00 pm whereas Time Period 2 is programmed to commence at 1:00 pm, the following will occur:

Time Period 1		
On-Time	Off-Time	
8:00 am	2:00 pm	
	1:00 pm	4:00 pm
	On-Time	Off-Time
Time Period 2		
Operates in Time Period 1 Setting		Operates in Time Period 2 Setting

Displaying Temperature in Celsius or Fahrenheit

The default setting of the Remote Control is to display the temperature in Fahrenheit.

However, the Remote Control can be changed to display temperature in Celsius by the following steps:

1. Ensure the Remote Control is switched off by using the **On/Off** button.
2. Press and hold the “-” button.
3. While the “-” button is held down, press and release the “+” button, this will toggle the temperature display between °C and °F.

This setting is stored in memory hence the Remote Control will continue to display the temperature in Celsius even if the battery is replaced.

IMPORTANT!

The transmitter and receiver in this box must be coded together before proceeding to program the remote to function.

Please follow the instructions under “Matching Remote Control and Receiver ID Code” on page 4 in the enclosed manual, and follow the coding instructions carefully. Failure to code these together will result in malfunction of the remote control device.